



LEAK-PROOF SEWAGE FOR SEEPAGE-PROOF STRUCTURES

TECHNICAL MANUAL



ULTRAFIT[®]

SWR Piping Systems

PRINCE[®]

PIPING SYSTEMS



**ZERO DEFECT
CHOICE**



Greener Better Together



Prince Pipes is not about creating products that are different but providing solutions that make a difference. From our zero defect manufacturing process that involves using recycled plastic to designing and equipping our plants with solar panels and various other energy saving manufacturing techniques, our endeavor has always been to further bring down the emission levels. Our strong belief in the concept of "better lasts longer" has not only helped us deliver premium quality products but also ensure lesser consumption. Together with our channel partners and plumbers, we are sure to leave a strong legacy for the generations to come.

THE JOURNEY

- 
- 2021**

 - Manufacturing unit commissioned at Sangareddy, Telangana, to strengthen our strategic presence in Southern India
 - Prince Pipes awarded "Brand of The Year - Pipes" at Realty + INEX Awards 2021
 - 2020**

 - Prince Pipes Product collaborates with Lubrizol, the world's largest manufacturers and inventors of CPVC compounds
 - Technical collaborates with Tooling Holland, a global leader in plastic moulds manufacturing
 - 2019**

 - Manufacturing unit at Jobner, Rajasthan to cater to increasing volume demand
 - Company successfully listed on BSE and NSE
 - 2018**

Prince Pipes announced bollywood actor Akshay Kumar as its brand ambassador.
 - 2017**

 - Prince Pipes became a Public Limited Company.
 - "Economic Times Polymers Award (Excellence in Plastics)" for excellence in building and construction (plumbing) in the large enterprises category
 - 2016**

Mr. Parag Chheda presented with the "Inspiring Business Leader Award" by Economic Times
 - 2015**

 - Mr. Jayant Chheda received the "Lifetime Achievement Award" at Vinyl India Conference
 - "IMEA Award" for the Haridwar factory by Frost & Sullivan
 - 2014**

Prince Pipes received "Asia's Most Promising Brand Award" by World Consulting and Research Corporation Delhi
 - 2012**

Prince Pipes acquired "Trubore"- a renowned brand of southern India from Chemplast Sanmar Group along with their two manufacturing units at Kolhapur & Chennai
 - 2010**

 - Winner of "Best SME" at the Emerging India Awards 2010 by ICICI Bank, CNBC TV 18 & CRISIL
 - Winner of "Outstanding Quality Contribution In Pipes Sector" by Bloomberg EPC world
 - 2008**

Manufacturing unit established at Haridwar (Uttarakhand) to cater to the increasing demand for Prince Pipes products
 - 2005**

Prince Pipes achieved the ₹100 Crore benchmark
 - 2000**

Manufacturing unit established at Dadra (Silvassa - D & N.H) to augment the pipe manufacturing capacity by setting up a new extrusion unit
 - 1998**

ISO Certification earned by ensuring compliance to every step of the quality management system
 - 1995**

Manufacturing unit established at Athal (Silvassa-D & N.H) to set-up a large scale Injection Moulding Unit which marked the beginning of Prince Pipes being one of the market leaders in PVC Fittings
 - 1987**

 - Mr. Jayant Chheda commenced manufacturing unit of PVC Products
 - 1st PVC Fittings Manufacturing Unit initiated to provide total piping solutions

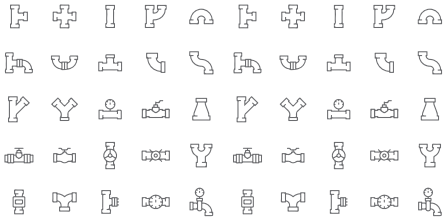

CONTENTS

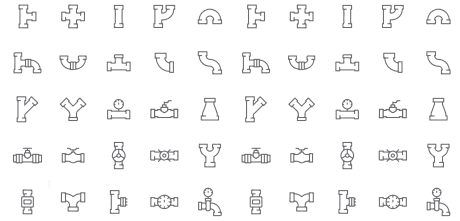

01

Manufacturing units

02

Certifications & awards

03

- Soil, waste and rainwater system
- Prince uPVC Ultrafit system

04

Features, benefits & applications

05

- Standards for pipes & fittings
- Pipes dimension

06

Fittings dimensions - Rubber ring joint

12

Fittings dimensions - Solvent joint

21

Trap fittings

24

Accessories & rubber lubricant

25

Pan connector

26

- Quality test
- Thermal movement and pipe support

27

Handling, storage and transportation

28

- Few important design principles
- Testing the installation

29

Joining techniques

30

Joining methods - Do's & Don'ts

34

Chemical resistance chart of uPVC

40

Warranty

MANUFACTURING UNITS



SANGAREDDY EST. 2021



JAIPUR EST. 2019



KOLHAPUR EST. 2012



CHENNAI EST. 2012



HARIDWAR EST. 2008



DADRA EST. 2000



ATHAL EST. 1995

CERTIFICATIONS

Certificate

Standard: **ISO 9001:2015**
 Certificate Registr. No: **01 100 203034963**

Certificate Holder: **PRINCE PIPES AND FITTINGS LTD**
 Survey No.1321/1/12 Abhal Road, Village Abhal,Naroli, Silvassa- 38235, Dadra & Nagar Haveli, India.

Scope: **Manufacture of uPVC, CPVC and HDPE Fittings.**

Proof has been furnished by means of an audit that the requirements of ISO 9001:2015 are met.
 The certificate is valid from 2021-05-28 until 2024-05-27.

2021-05-28

TUV Rheinland Cert Guide
 Am Group Steel 51105 Kdn

IAF DAKKS
 TÜV Rheinland
 Precisely Right

www.tuv.com

Certificate

Standard: **ISO 9001:2015**
 Certificate Registr. No: **01 100 203083401**

Certificate Holder: **PRINCE PIPES AND FITTINGS LTD**
 Bhasara No1548, 1549, 743, Sakampur, Musaboni-2, Haridwar -249402, Uttarakhand, India.

Scope: **Manufacture of uPVC, CPVC, PPR and HDPE Pipes and Fittings.**

Proof has been furnished by means of an audit that the requirements of ISO 9001:2015 are met.
 The certificate is valid from 2021-05-28 until 2024-05-27.

2021-05-28

TUV Rheinland Cert Guide
 Am Group Steel 51105 Kdn

IAF DAKKS
 TÜV Rheinland
 Precisely Right

www.tuv.com

Certificate

Standard: **ISO 9001:2015**
 Certificate Registr. No: **01 100 2030934**

Certificate Holder: **PRINCE PIPES AND FITTINGS LTD**
 The Ruby, 8th floor, 29, Senapati Bapat Marg (Tulsi Pipe Road), Dadar - West, Mumbai 400028, Maharashtra, India.

Scope: **Design, Development, Marketing, Procurement, Purchase/CAPEX, H.R., Logistics Management and Corporate Support functions.**

Proof has been furnished by means of an audit that the requirements of ISO 9001:2015 are met.
 The certificate is valid from 2021-05-28 until 2024-05-27.

2021-05-28

TUV Rheinland Cert Guide
 Am Group Steel 51105 Kdn

IAF DAKKS
 TÜV Rheinland
 Precisely Right

www.tuv.com

Certificate

Standard: **ISO 14001:2015**
 Certificate Registr. No: **01 104 20308334**

Certificate Holder: **PRINCE PIPES AND FITTINGS LTD**
 The Ruby, 8th floor, 29, Senapati Bapat Marg (Tulsi Pipe Road), Dadar - West, Mumbai 400028, Maharashtra, India.

Scope: **Design, Development, Marketing, Procurement, Purchase/CAPEX, H.R., Logistics Management and Corporate Support functions.**

Proof has been furnished by means of an audit that the requirements of ISO 14001:2015 are met.
 The certificate is valid from 2021-05-28 until 2024-05-27.

2021-05-28

TUV Rheinland Cert Guide
 Am Group Steel 51105 Kdn

IAF DAKKS
 TÜV Rheinland
 Precisely Right

www.tuv.com

Certificate

Standard: **ISO 45001:2018**
 Certificate Registr. No: **01 213 20308334**

Certificate Holder: **PRINCE PIPES AND FITTINGS LTD**
 The Ruby, 8th floor, 29, Senapati Bapat Marg (Tulsi Pipe Road), Dadar - West, Mumbai -400028, Maharashtra, India.

Scope: **Design, Development, Marketing, Procurement, Purchase/CAPEX, H.R., Logistics Management and Corporate Support functions.**

Proof has been furnished by means of an audit that the requirements of ISO 45001:2018 are met.
 The certificate is valid from 2021-05-28 until 2024-05-27.

2021-05-28

TUV Rheinland Cert Guide
 Am Group Steel 51105 Kdn

IAF DAKKS
 TÜV Rheinland
 Precisely Right

www.tuv.com

Certificate

Standard: **ISO 50001:2018**
 Certificate Registr. No: **01 407 183634001**

Organization: **Prince Pipes and Fittings Ltd,**
 Kasaria No. 1548, 1549 & 743, Sakampur, Musaboni - 2, India, Uttarakhand, India

Site: **PRINCE PIPES AND FITTINGS LTD,**
 The Ruby, 8th floor, 29, Senapati Bapat Marg, (Tulsi Pipe Road), Dadar - West, MUMBAI 400028, India

Scope: **Design, Development, Marketing, Procurement, Purchase / CAPEX, H.R, Logistics Management and Corporate Support Functions.**

Proof has been furnished by means of an audit that the requirements of ISO 50001:2018 are met.
 The certificate is valid in conjunction with the main certificate 01 407 1836340 from 2021-05-21 until 2024-05-20.

2021-05-21

TUV Rheinland Cert Guide
 Am Group Steel 51105 Kdn

IAF DAKKS
 TÜV Rheinland
 Precisely Right

www.tuv.com

AWARDS



SOIL, WASTE AND RAINWATER SYSTEM

The soil, waste and rain (SWR) drainage system removes effluent and waste water discharge from the house, including terrace rainwater to underground drainage. The main objective of SWR system is to collect and drain waste matter to maintain healthy condition in building. SWR systems are designed such a way to dispose waste water quickly and rapidly carry it away from residential premises to a discharge point as well as to arrest foul gases from sewers and septic tank from entering residential area. SWR system generally consists of a vertical drainage stack & a vent stack connected with horizontal house drain branches through traps, tee/wye/bend fittings.

PRINCE uPVC ULTRAFIT SYSTEM products are manufactured according to IS 13592 & IS 14735 requirements. Indian standards clearly indicate the usage of Type A & Type B drainage pipes, which are as follows -

- **Type A** pipes shall be used only for stack vent & rain water drainage purposes.
- **Type B** pipes shall be used to convey and discharge soil and waste water.

PRINCE uPVC ULTRAFIT SYSTEM

'Unplasticized Polyvinyl Chloride means 'uPVC, which means no plasticizer has been added/used to PVC compound. Unplasticized PVC ('uPVC) is also popularly known as rigid PVC. PVC has been considered to be one of the most durable polymers for both underground and above ground pipes & fitting applications including transportation of drinking water, irrigation systems, soil and waste, sewage and underground drainage and industrial applications. Its light weight, high mechanical strength, high durability, resistance to UV exposure and low reactivity make it most suitable for these applications. Moreover uPVC have favorable environmental profiles and are 100% recyclable.

BASIC IMPORTANT MATERIAL PROPERTIES

Chemical formula	$(C_2H_3Cl)_n$
Coefficient of linear expansion	$\approx 0.06\text{mm/m/}^\circ\text{C}$
Density	$\approx 1.48\text{ gram/cm}^3$
Heat conductivity	$\approx 0.16\text{ W/m/}^\circ\text{C}$
Surface resistance	$>10^{12}\Omega$

FIRE RESISTANT PROPERTIES

PVC has excellent fire resisting properties. The flash ignition temperature of PVC exceeds 390°C. The LOI (Limiting Oxygen Index) amounts to 45 for PVC. This means that a PVC material requires 45% oxygen to burn, but since there is only 21% oxygen present in earth's atmosphere, PVC does not sustain the burning process and extinguishes by itself after the removal of fire source. Below diagram depicts LOI values of other materials such as cotton, polypropylene (PP), polyethylene (PE), polyvinyl chloride & chlorinated polyvinyl chloride.

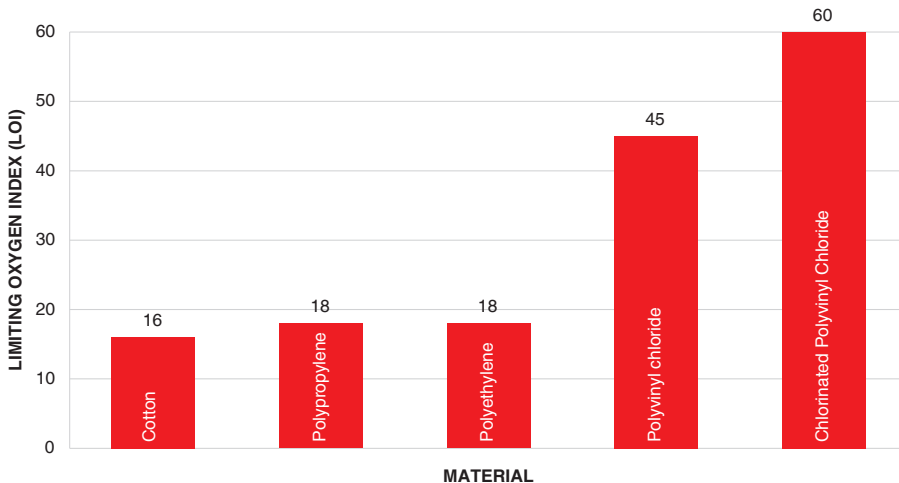

SWR PIPING SYSTEMS ARE AN EFFECTIVE SOLUTION FOR SOIL, WASTE AND RAINWATER

FEATURES AND BENEFITS



Lighter than conventional C.I pipes but strong



Compatible with other drainage products



Easy to install with low assembly force



Very smooth internal bore, efficient disposal and allows for more hydraulic capacity



Leak-proof joints



Rubber ring joints allow provision against thermal expansion & contraction



Very long operating life, more than 50 years



Cost-efficient



Light weight and easy to transport



Easy to maintain after installation for inspection, cleaning & repairs



PVC is self-extinguishing



Completely resistant to pitting & general corrosion



PVC is resistant to chemical reactions from the chemical acids, alkalis & salt solutions present in soil and waste water



External surfaces are resistant to the activity of concealed or ground waters, and they are also resistant to harmful chemicals



Resistant to stray currents, PVC is a non-conducting material



No sediment formation due to very smooth bore



Microbiological resistant

APPLICATIONS



Inside & outside building drainage systems, including ventilation



Rainwater discharge & harvesting for residential & commercial buildings



Industrial buildings and public utilities

STANDARDS FOR PIPES AND FITTINGS

Pipes				Fittings		
Size (mm)	Standard	Type	End Connection	Size (mm)	Standard	End Connection
40 to 160	IS 13592	Type A For ventilation pipe work, rain water discharge and harvesting.	Rubber Ring & Solvent Joint	75, 90, 110, 160	IS 14735	Rubber Ring Joint
		Type B For soil and waste discharge system.		40 to 160		Solvent Joint

PIPES DIMENSIONS



Nominal Bore (mm)	Nominal Outside Diameter (mm)	Mean Outside Diameter		Wall Thickness			
				Type "A"		Type "B"	
		Minimum (mm)	Maximum (mm)	Minimum (mm)		Maximum (mm)	
40	40.0	40.00	40.30	1.80	2.20	3.20	3.80
50	50.0	50.00	50.30	1.80	2.20	3.20	3.80
63	63.0	63.00	63.30	1.80	2.20	3.20	3.80
75	75.0	75.00	75.30	1.80	2.20	3.20	3.80
90	90.0	90.00	90.30	1.90	2.30	3.20	3.80
110	110.0	110.00	110.40	2.20	2.70	3.20	3.80
160	160.0	160.00	160.50	3.20	3.80	4.00	4.60

SWR PIPING SYSTEMS ARE AN EFFECTIVE SOLUTION FOR SOIL, WASTE AND RAINWATER

FITTINGS DIMENSIONS - RUBBER RING JOINT



COUPLER (ISI)

Size (mm)	C	ØD	ØE	H
75	49.00	81.50	89.60	101.00
90	51.00	96.20	104.60	130.00
110	67.00	116.60	125.60	137.00
160	82.00	168.00	180.20	170.00

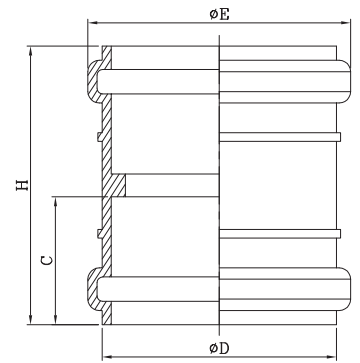

BEND 87.5° (ISI)

Size (mm)	C	ØD	ØE	H	L
75	45.00	75.00	89.60	139.60	130.45
90	51.00	90.00	104.60	161.10	151.75
110	58.00	110.00	125.60	189.55	179.25
160	74.00	160.00	180.20	261.60	248.45

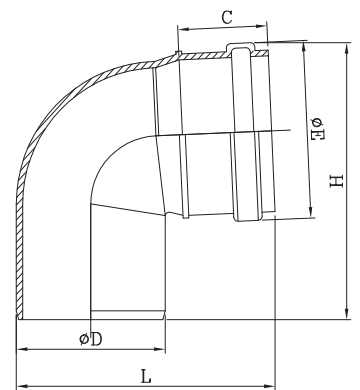

BEND 45° (ISI)

Size (mm)	C	ØD	ØE	H	L
75	45.00	75.00	89.60	154.15	118.25
90	51.00	90.00	104.60	173.90	137.20
110	58.00	110.00	125.60	202.05	163.00
160	74.00	160.00	180.20	271.80	229.50

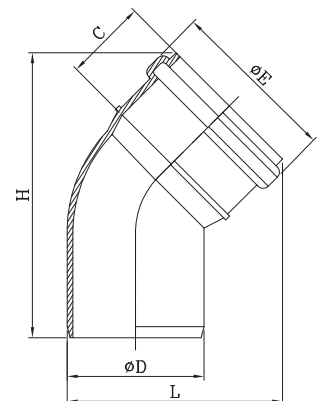



BEND WITH DOOR 87.5° (ISI)

Size (mm)	C	ØD	ØE	H	L
75	45.00	75.00	89.60	142.80	144.75
90	51.00	90.00	104.60	164.85	166.95
110	58.00	110.00	125.60	193.80	196.70
160	74.00	160.00	180.20	251.80	258.30

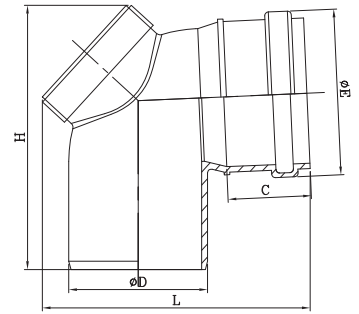

HORN BEND WITH DOOR 87.5° 110 X 50 mm (ISI)

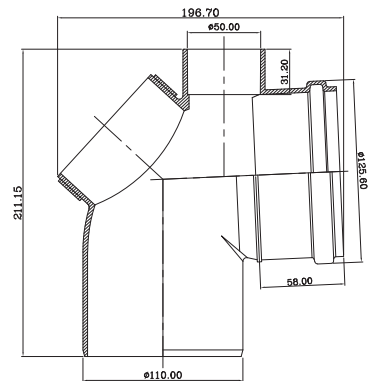

SINGLE T (ISI)

Size (mm)	C	ØD	ØE	H	L
75	45.00	75.00	89.60	181.00	142.25
90	51.00	90.00	104.60	226.00	163.90
110	58.00	110.00	125.60	247.00	192.35
160	74.00	160.00	180.20	332.00	264.90

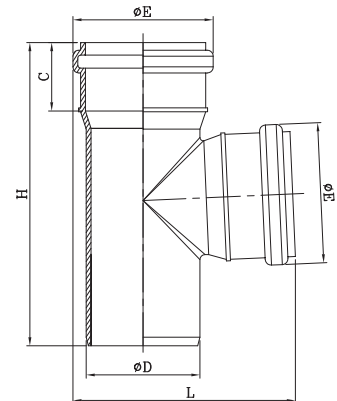

Refer Figure - 1

Figure - 1



REDUCING SINGLE T (ISI)

Size (mm)	C1	C2	ØD	ØE1	ØE2	H	L
110 x 75	58.00	45.00	110.00	125.60	89.60	216.00	179.15
160 x 75	74.00	45.00	160.00	180.20	89.60	332.00	230.55
160 x 110	74.00	58.00	160.00	180.20	125.60	323.00	243.85

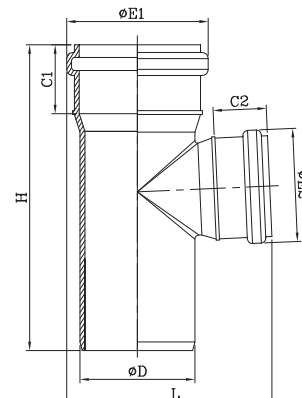

Refer Figure - 2

Figure - 2



SINGLE T WITH DOOR (ISI)

Size (mm)	C	ØD	ØE	H	L
75	45.00	75.00	89.60	181.00	159.95
90	51.00	90.00	104.60	226.00	181.60
110	58.00	110.00	125.60	247.00	214.55
160	74.00	160.00	180.20	332.00	291.80

Refer Figure - 1

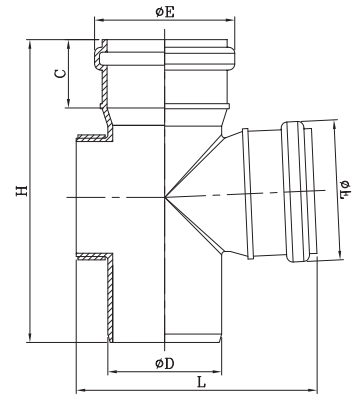

Figure - 1



REDUCING SINGLE T WITH DOOR (ISI)

Size (mm)	C1	C2	ØD	ØE1	ØE2	H	L
110 x 75	58.00	45.00	110.00	125.60	89.60	216.00	196.35
160 x 110	74.00	58.00	160.00	180.20	125.60	332.00	263.75

Refer Figure - 2

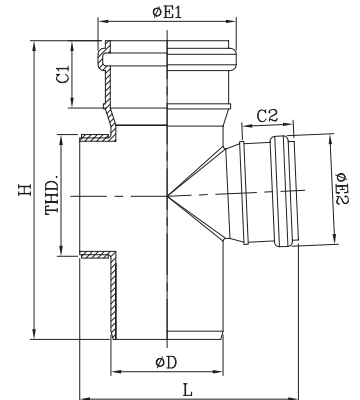
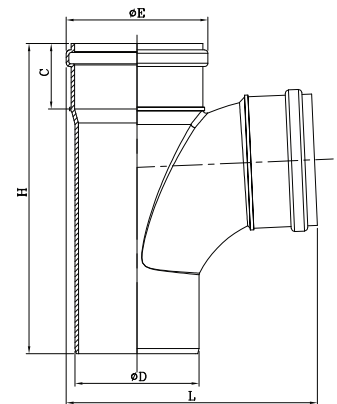

Figure - 2



SWEPT SINGLE T 87.5° (ISI)

Size (mm)	C	ØD	ØE	H	L
110	58.00	110.00	125.60	247.85	222.65



SWEPT SINGLE T 87.5° WITH DOOR (ISI)

Size (mm)	C	ØD	ØE	H	L
110	58.00	110.00	125.60	247.85	244.85

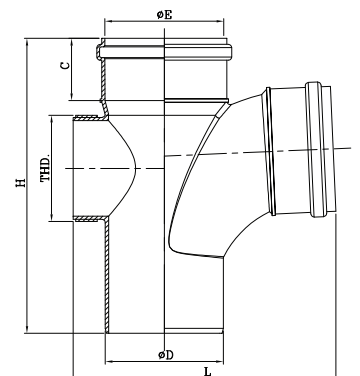



DOUBLE T (ISI)

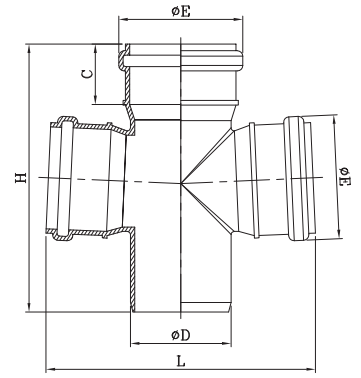

Size (mm)	C	ØD	ØE	H	L
75	45.00	75.00	89.60	181.00	194.90
90	51.00	90.00	104.60	226.00	225.20
110	58.00	110.00	125.60	247.00	259.10



DOUBLE T WITH DOOR (ISI)

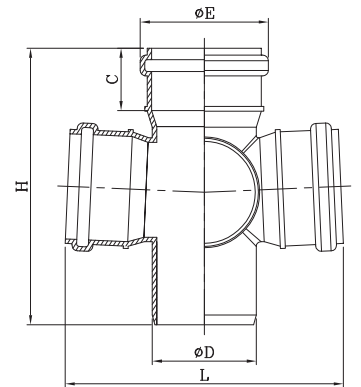

Size (mm)	C	ØD	ØE	H	L
75	45.00	75.00	89.60	181.00	194.90
90	51.00	90.00	104.60	226.00	225.20
110	58.00	110.00	125.60	252.00	259.10

SINGLE T WITH RH & LH DOOR (ISI)

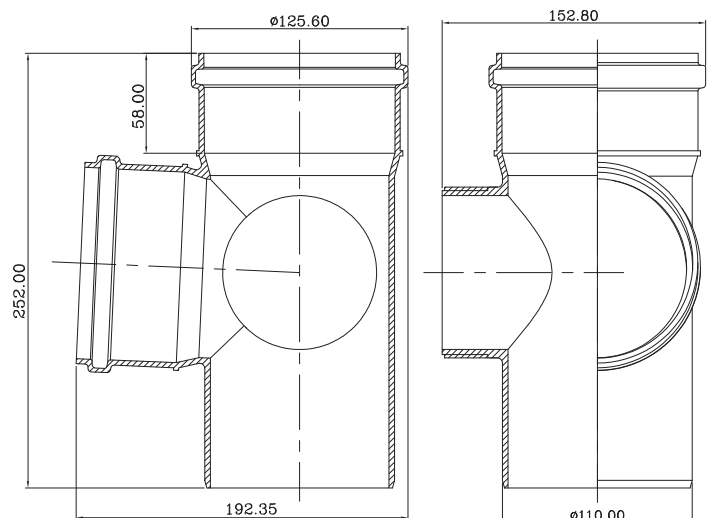

SWR PIPING SYSTEMS ARE AN EFFECTIVE SOLUTION FOR SOIL, WASTE AND RAINWATER



SINGLE Y 45° (ISI)

Size (mm)	C	ØD	ØE	H	L
75	45.00	75.00	89.60	211.00	174.45
90	51.00	90.00	104.60	260.00	204.30
110	58.00	110.00	125.60	291.00	244.10
160	74.00	160.00	180.20	407.00	344.20

Refer Figure - 1

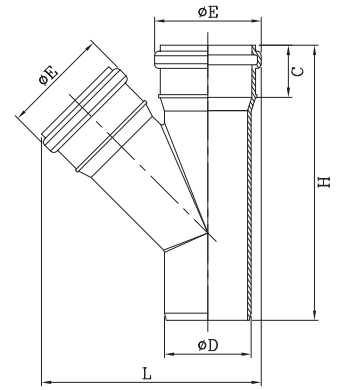

Figure - 1



REDUCING SINGLE Y 45° (ISI)

Size (mm)	C1	C2	ØD	ØE1	ØE2	H	L
110 X 75	58.00	45.00	110.00	125.60	89.60	252.00	216.65
160 X 110	74.00	58.00	160.00	180.20	125.60	407.00	311.35

Refer Figure - 2

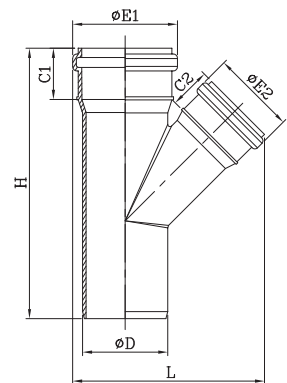

Figure - 2



SINGLE Y 45° WITH DOOR (ISI)

Size (mm)	C	ØD	ØE	H	L
75	45.00	75.00	89.60	211.00	192.15
90	51.00	90.00	104.60	260.00	222.00
110	58.00	110.00	125.60	291.00	266.30
160	74.00	160.00	180.20	407.00	364.10

Refer Figure - 1

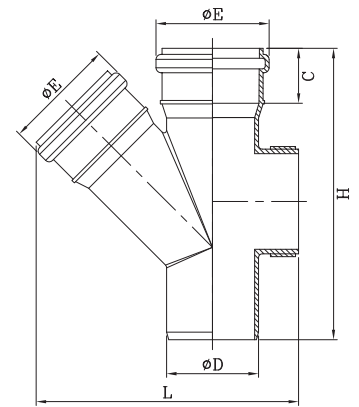

Figure - 1



REDUCING SINGLE Y 45° WITH DOOR (ISI)

Size (mm)	C1	C2	ØD	ØE1	ØE2	H	L
110 X 75	58.00	45.00	110.00	125.60	89.60	252.00	233.85
160 X 110	74.00	58.00	160.00	180.20	125.60	407.00	331.35

Refer Figure - 2

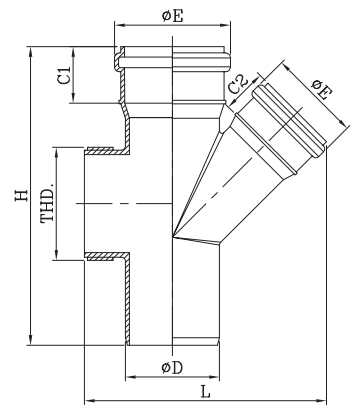
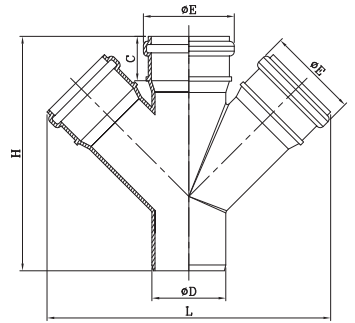

Figure - 2



DOUBLE Y 45° (ISI)



Size (mm)	C	ØD	ØE	H	L
75	45.00	75.00	89.60	211.00	259.30
110	58.00	110.00	125.60	291.00	362.30



DOUBLE Y 45° WITH DOOR (ISI)

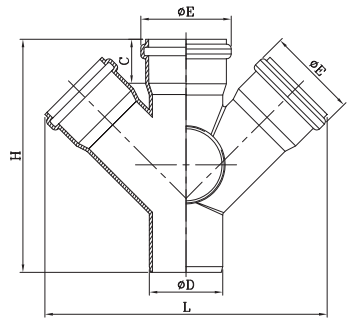

Size (mm)	C	ØD	ØE	H	L
75	45.00	75.00	89.60	211.00	259.30
110	58.00	110.00	125.60	291.00	362.30



CLEANSING PIPE (ISI)

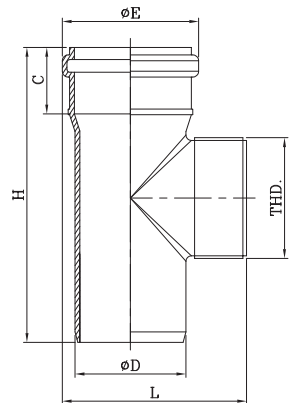

Size (mm)	C	ØD	ØE	H	L
75	45.00	75.00	89.60	181.00	107.30
110	58.00	110.00	125.60	247.00	147.80
160	74.00	160.00	180.20	332.00	200.10



REDUCER (ISI)

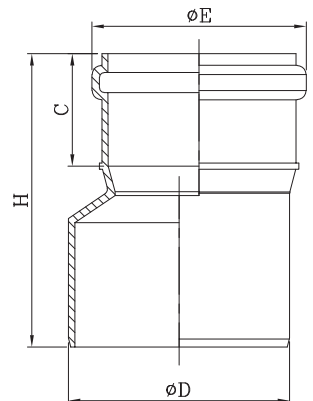

Size (mm)	C	ØD	ØE	H
110 X 75	45.00	110.00	75.00	89.60
110 X 90	51.00	110.00	90.00	104.60
160 X 110	65.00	160.00	126.50	201.00

FITTINGS DIMENSIONS - SOLVENT JOINT



COUPLER (ISI)

Size (mm)	C	ØD	H
75	54.00	81.50	111.00
90	56.00	96.20	140.00
110	63.00	116.55	143.00
160	87.00	168.70	178.50

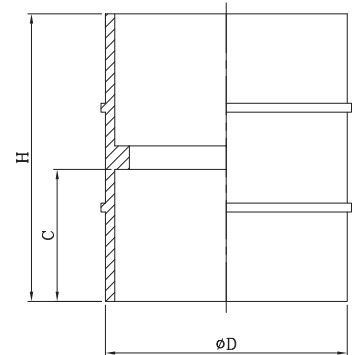

BEND 87.5° (ISI)

Size (mm)	C	ØD	H	L
75	50.00	75.00	136.15	135.50
90	56.00	90.00	157.50	156.75
110	63.00	110.00	185.50	184.25
160	81.00	160.00	256.50	255.50

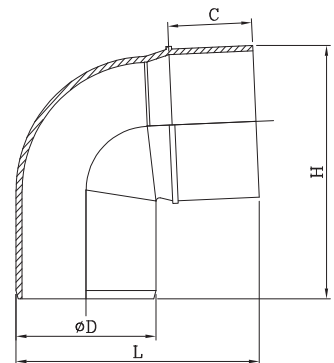

BEND 87.5° WITH DOOR (ISI)

Size (mm)	C	ØD	H	L
75	50.00	75.00	142.65	149.75
90	56.00	90.00	164.20	172.25
110	63.00	110.00	193.80	201.70
160	81.00	160.00	258.50	262.15

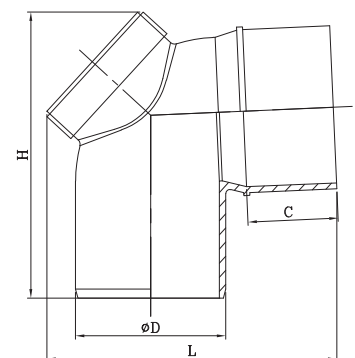



BEND 45° (ISI)

Size (mm)	C	ØD	H	L
75	50.00	75.00	157.65	121.80
90	56.00	90.00	178.50	141.65
110	63.00	110.00	205.50	166.50
160	81.00	160.00	276.80	234.50

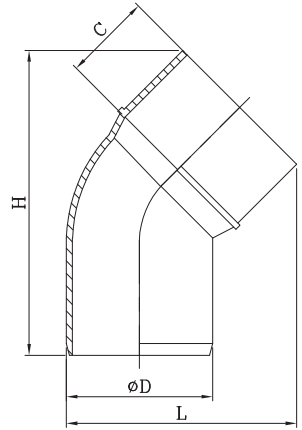

HORN BEND WITH DOOR 87.5° 110 X 50 mm (ISI)

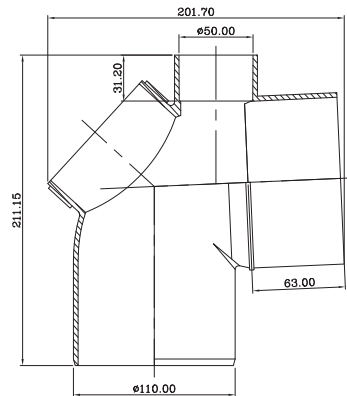

SINGLE T 87.5° (ISI)

Size (mm)	C	ØD	H	L
75	50.00	75.00	186.00	144.50
90	56.00	90.00	231.00	166.20
110	63.00	110.00	252.00	194.20
160	81.00	160.00	339.00	267.30

Refer Figure - 1

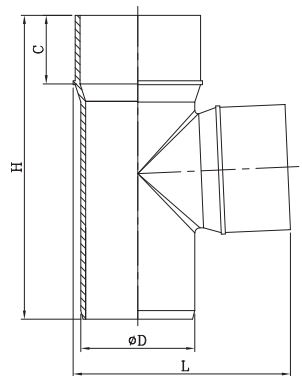

Figure - 1



REDUCING SINGLE T 87.5° (ISI)

Size (mm)	C1	C2	ØD	H	L
110 X 75	63.00	50.00	110.00	221.00	181.00
160 X 75	81.00	50.00	160.00	339.00	231.00
160 X 110	81.00	63.00	160.00	339.00	244.25

Refer Figure - 2

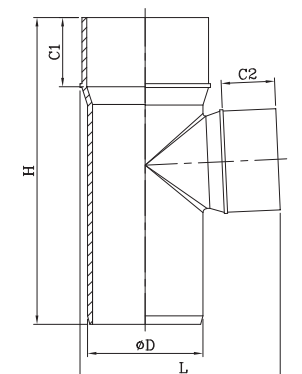

Figure - 2



SINGLE T 87.5° WITH DOOR (ISI)

Size (mm)	C	ØD	H	L
75	50.00	75.00	186.00	165.00
90	56.00	90.00	231.00	186.50
110	63.00	110.00	252.00	219.50
160	81.00	160.00	339.00	291.80

Refer Figure - 1

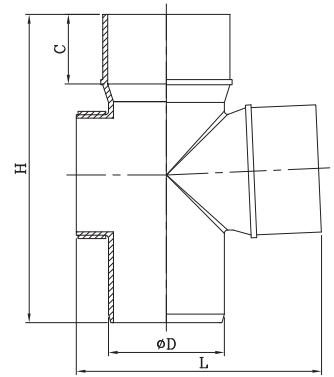

Figure - 1



REDUCING SINGLE T 87.5° WITH DOOR (ISI)

Size (mm)	C1	C2	ØD	H	L
110 X 75	63.00	50.00	110.00	221.00	201.00
160 X 110	81.00	63.00	160.00	339.00	268.75

Refer Figure - 2

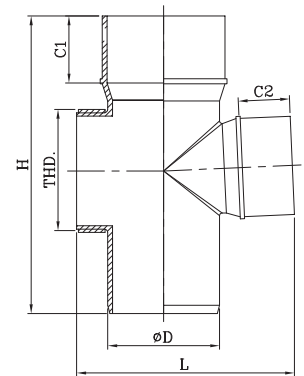
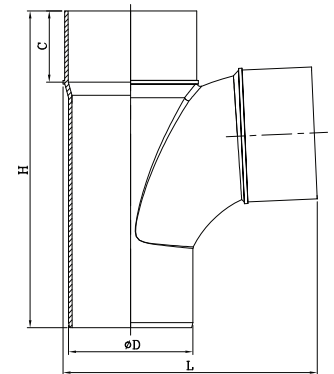

Figure - 2



SWEPT T 87.5° (ISI)

Size (mm)	C	ØD	H	L
110	63.00	110.00	279.85	224.65



SWEPT T 87.5° WITH DOOR (ISI)

Size (mm)	C	ØD	H	L
110	63.00	110.00	279.85	249.85

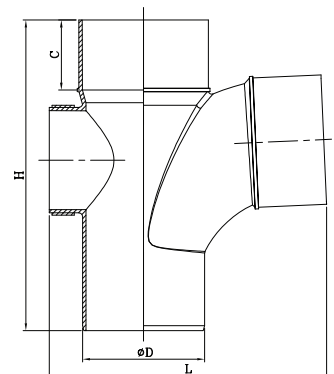



DOUBLE T 87.5° (ISI)

Size (mm)	C	ØD	H	L
75	50.00	75.00	186.00	205.00
90	56.00	90.00	230.00	235.20
110	63.00	110.00	257.00	269.00

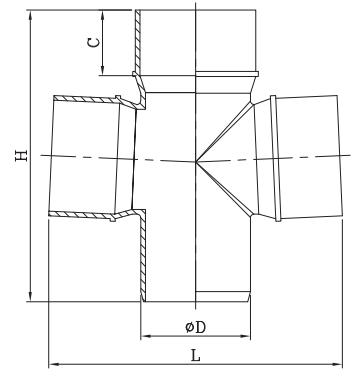

DOUBLE T 87.5° WITH DOOR (ISI)

Size (mm)	C	ØD	H	L
75	50.00	75.00	186.00	205.00
90	56.00	90.00	231.00	235.20
110	63.00	110.00	257.00	269.00

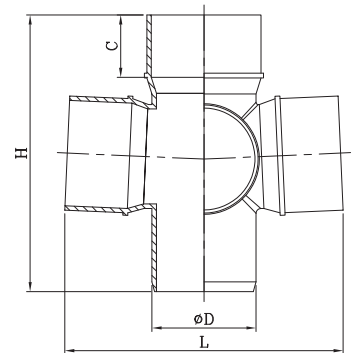

SINGLE Y 45° (ISI)

Size (mm)	C	ØD	H	L
75	50.00	75.00	216.00	175.50
90	56.00	90.00	265.00	205.15
110	63.00	110.00	296.00	244.50
160	81.00	160.00	414.00	344.50

Refer Figure - 1

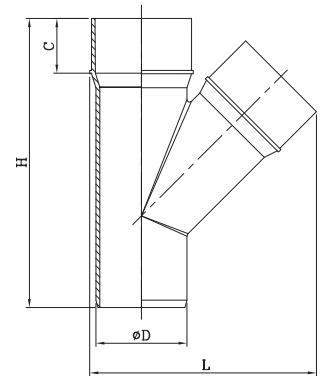

Figure - 1



REDUCING SINGLE Y 45° (ISI)

Size (mm)	C	C2	ØD	H	L
110 X 75	63.00	50.00	110.00	257.00	217.00
160 X 110	81.00	63.00	160.00	414.00	304.80

Refer Figure - 2

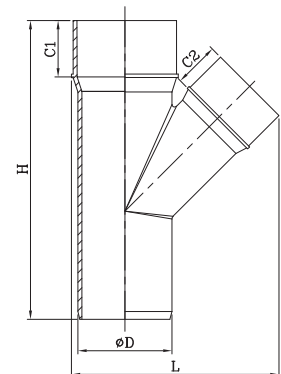

Figure - 2



SINGLE Y 45° WITH DOOR (ISI)

Size (mm)	C	ØD	H	L
75	50.00	75.00	216.00	195.70
90	56.00	90.00	265.00	225.50
110	63.00	110.00	296.00	269.70
160	81.00	160.00	414.00	369.00

Refer Figure - 1

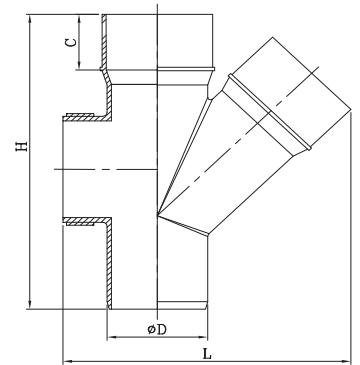

Figure - 1



REDUCING SINGLE Y 45° WITH DOOR (ISI)

Size (mm)	C	C2	ØD	H	L
110 X 75	63.00	50.00	110.00	257.00	237.40
160 X 110	81.00	63.00	160.00	414.00	334.80

Refer Figure - 2

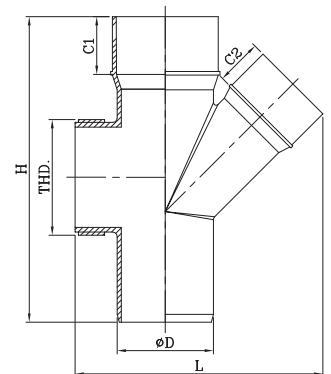
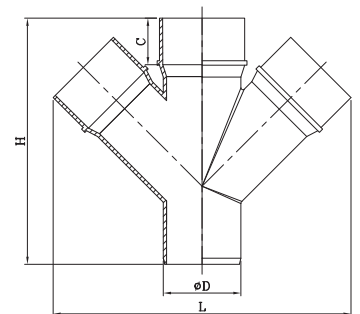

Figure - 2



DOUBLE Y 45° (ISI)

Size (mm)	C	ØD	H	L
75	50.00	75.00	216.00	266.35
110	63.00	110.00	296.00	369.50



DOUBLE Y 45° WITH DOOR (ISI)

Size (mm)	C	ØD	H	L
75	50.00	75.00	216.00	266.35
110	63.00	110.00	296.00	369.50

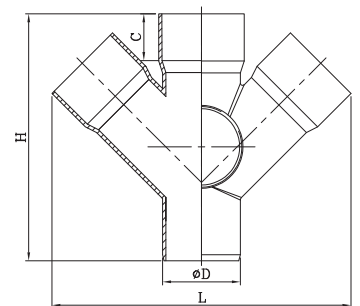



REDUCER

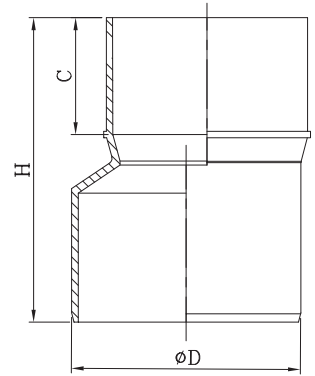

Size (mm)	C	ØD	H
110 X 75	50.00	110.00	145.00
160 X 110	69.00	160.00	207.00



REDUCING BUSH

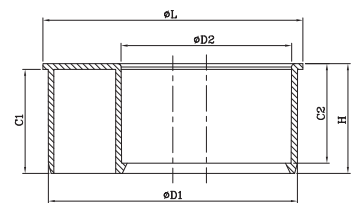

Size (mm)	C1	C2	ØD1	ØD2	H	ØL
110 X 50	46.00	31.20	110.00	50.38	48.50	115.00
110 X 63	46.00	38.00	110.00	63.40	48.50	115.00
110 X 75	46.00	44.00	110.00	75.40	48.50	115.00



CLEANSING PIPE (ISI)

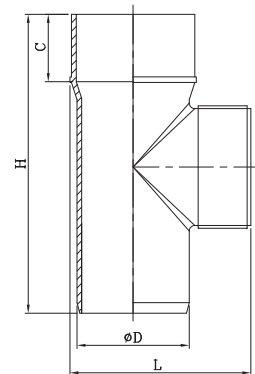

Size (mm)	C	ØD	H	L
75	50.00	75.00	186.00	104.50
110	63.00	110.00	252.00	144.65
160	81.00	160.00	339.00	195.50



STRIP CONNECTOR

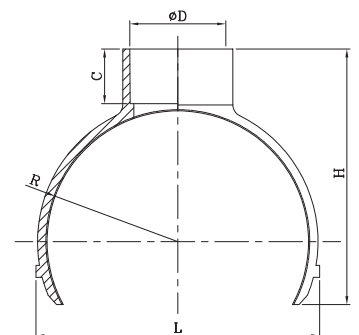

Size (mm)	ØD	C	R	H	L
110 X 40	40.34	23.00	55.00	107.50	119.30
110 X 50	50.38	28.00	55.00	112.50	119.30
110 X 63	63.40	32.00	55.00	116.50	119.30



VENT COWL (ISI)

WITHOUT JALI

Size (mm)	C	ØD	H
50	20.00	54.40	60.00
63	22.00	67.40	65.00
75	22.00	79.40	73.00
90	22.00	94.40	75.00
110	24.00	114.46	87.50
160	24.00	164.70	130.00

WITH JALI

Size (mm)	C	ØD	H
63	22.00	67.40	65.00
75	22.00	79.40	73.00
90	22.00	94.40	75.00
110	24.00	114.46	87.50

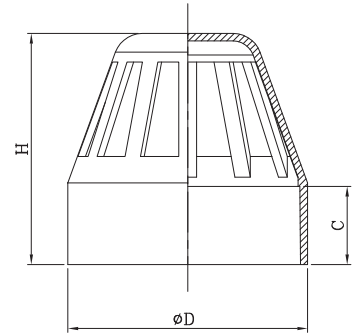

VENT COWL WITH PVC JALI 110 mm (ISI)

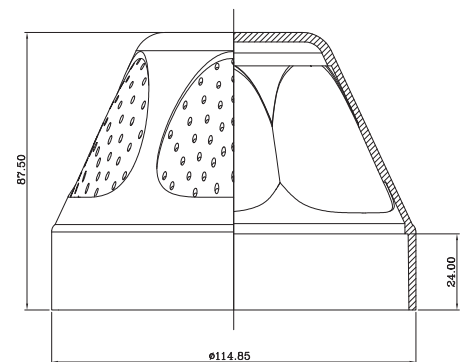

BOSS CONNECTOR 110 X 63 mm

(SOLVENT JOINT)

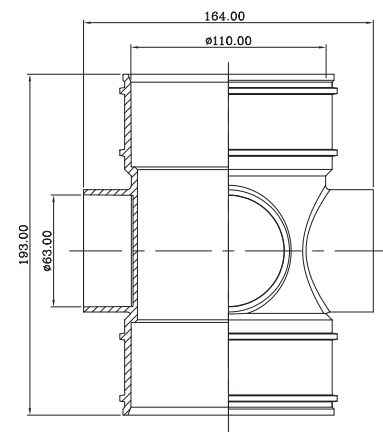



HEIGHT RISER 6'' (HT)
110 X 50 X 40mm

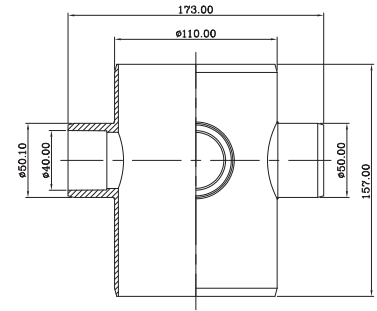

SOCKET PLUG (ISI)

Size (mm)	C	ØD	H	ØL
40	26.00	40.10	28.50	49.00
50	30.00	50.10	32.50	55.00
75	45.00	75.00	49.50	95.00
110	48.00	110.00	52.50	130.00

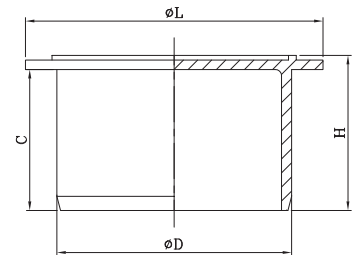

PIPE CLIP

Size (mm)	ØD	H	L
40	40.00	74.00	74.00
50	50.00	84.00	86.00
63	63.00	97.00	102.00
75	75.00	110.50	124.00
90	90.00	125.00	142.00
110	110.00	150.00	160.00
160	160.00	201.00	214.00

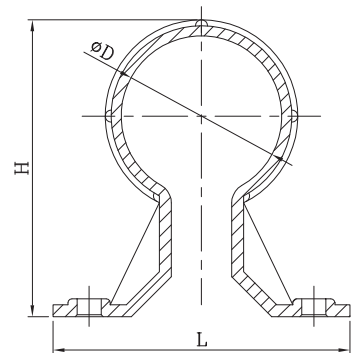

PIPE CLIP WITH BRACKET
110 mm

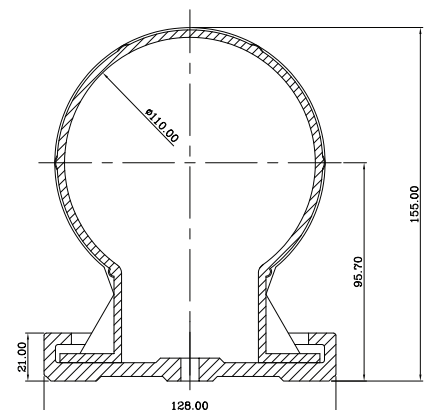

AERATOR
110 X 75mm
 (RUBBER RING JOINT)

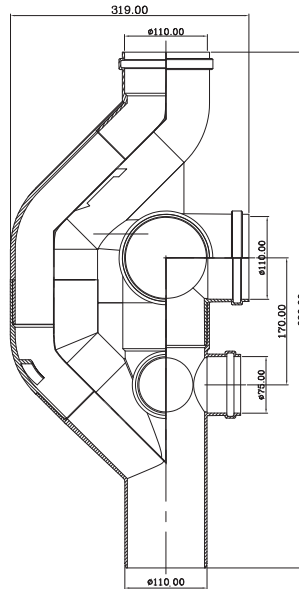

AERATOR
110 X 75mm
 (SOLVENT JOINT)

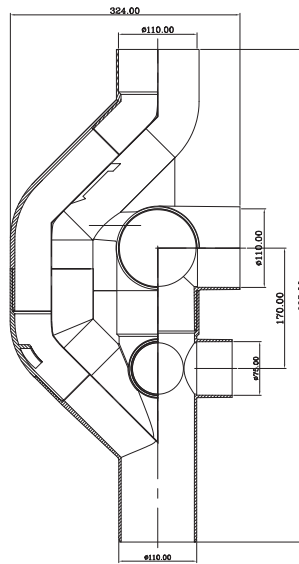

AERATOR
110 X 75mm
 (SOLVENT & RUBBER RING JOINT)

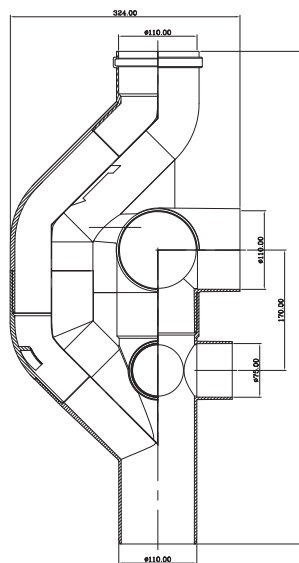

TRAP FITTINGS



NAHANI DRAIN

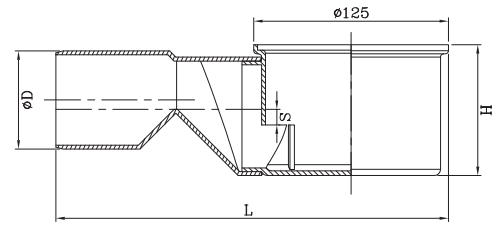

(SOLVENT JOINT)

Size (mm)	ØD	H	L	S
110 X 63	63.00	84.00	252.00	10.00
110 X 75 (ISI)	75.00	84.00	252.00	10.00
110 X 90	96.00	84.00	252.00	10.00
110 X 110	115.00	84.00	252.00	10.00



SINGLE PIECE NAHANI DRAIN 110 X 75mm (ISI)

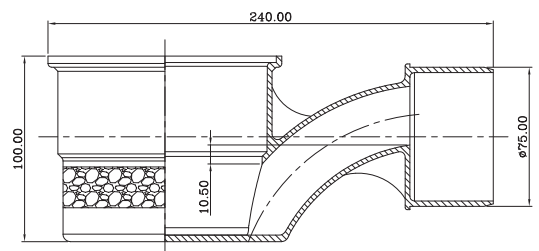

(SOLVENT JOINT)



MULTI FLOOR TRAP

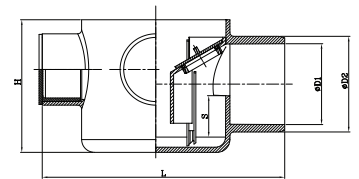

Figure - 1

(4" HT)

Size (mm)	ØD	H	L	S
110 X 75	75.00	100.00	209.00	27.50

Refer Figure - 1

(7" HT)

Size (mm)	ØD	H	L	S
110 X 75	75.00	177.00	208.00	50.00

Refer Figure - 2

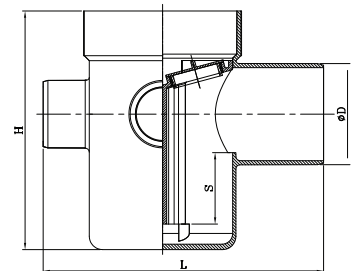
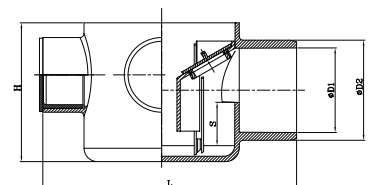

Figure - 2



MULTI FLOOR TRAP



Size (mm)	ØD1	ØD2	H	L	S
110 X 75/63	63.00	75.00	100.00	209.00	27.50



MULTI FLOOR TRAP SPECIAL FLAP 110 X 75 mm

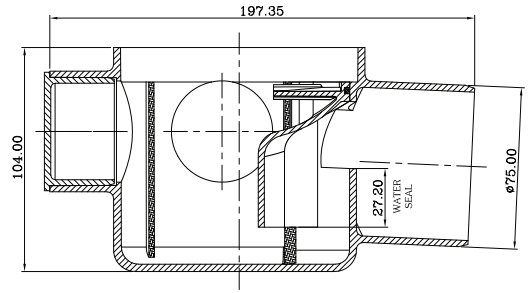

FLOOR TRAP 110 X 75/63mm

(SOLVENT JOINT)

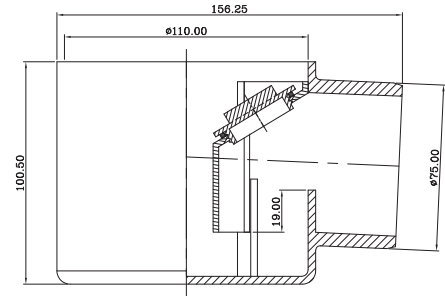

GULLY TRAP WITH JALI

Size (mm)	ØD	H	L	S
110	110.00	245.00	271.80	53.70

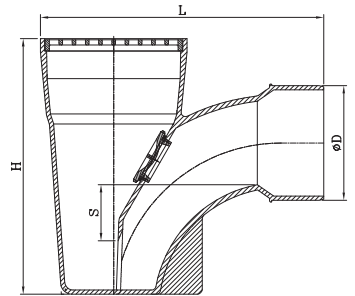

BELL MOUTH TRAP

Size (mm)	C	H1	H2	L	S
110 X 75	61.00	194.00	254.20	378.70	85.85

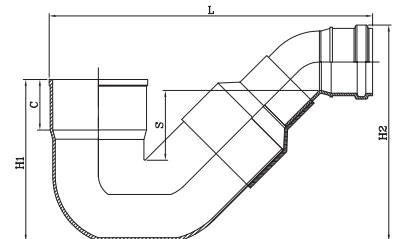

P-TRAP

(SOLVENT JOINT)

Size (mm)	C	ØD	H1	H2	L	S
75 X 75	45.00	75.00	141.00	167.70	254.10	28.95
110 X 110	61.00	110.00	194.85	224.15	348.60	27.45
125 X 110	69.20	110.00	203.35	224.15	356.10	27.45

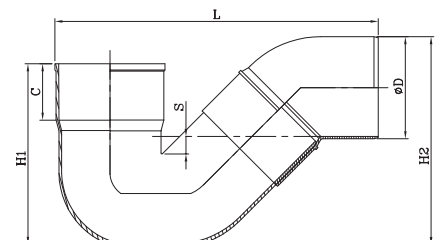



P-TRAP SHORT BODY

(SOLVENT JOINT)

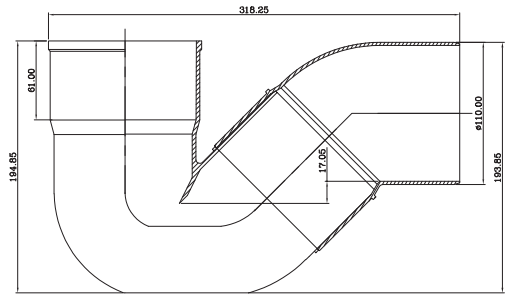

Q-TRAP

(SOLVENT JOINT)

Size (mm)	C	ØD	H1	H2	L	S
110 X 110	61.00	110.00	194.85	223.50	406.15	26.80
125 X 110	69.20	110.00	203.35	223.50	413.65	26.80

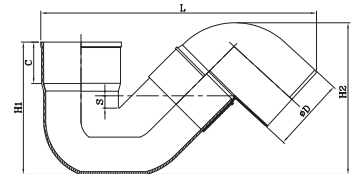

S-TRAP

(SOLVENT JOINT)

Size (mm)	C	ØD	H1	H2	L	S
110 X 110	61.00	110.00	194.85	248.00	416.55	50.95
125 X 110	69.20	110.00	203.33	247.70	423.90	50.35

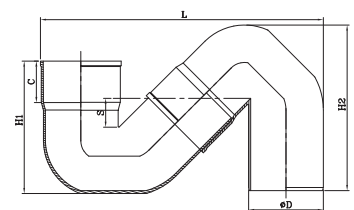

PAN CONNECTOR

STRAIGHT, OFFSET (18 mm & 40 mm) &
COLLAPSIBLE 125 X 110 mm

ACCESSORIES



DOOR CAP

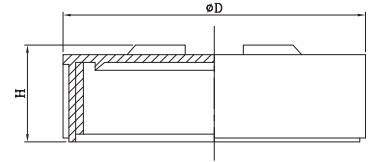

Size (mm)	ØD	H
50	54.00	19.50
63	65.00	19.50
75	78.00	25.00
90	92.00	26.00
110	106.00	29.50



ROUND TYPE JALLI 110mm FOR NAHANI TRAP

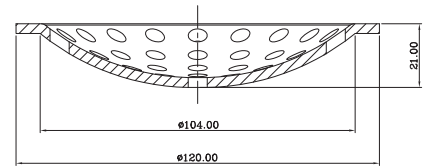

SQUARE TYPE JALLI 110mm FOR GULLY TRAP

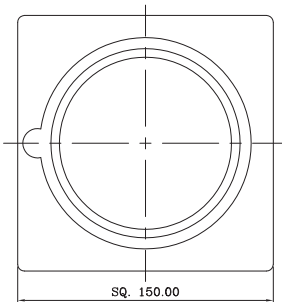
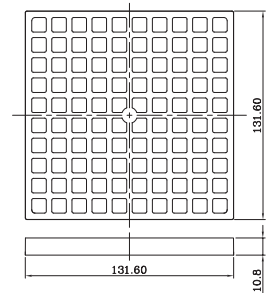

COVER/ SQUARE BODY FOR ROUND JALLI 6" X 6"



RUBBER RING (DUAL)

Size (mm)
75
90
110
160

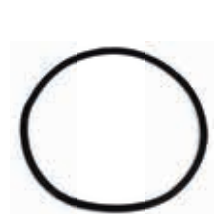

RUBBER DOOR GASKET

Size (mm)
50
63
75
90
110

RUBBER LUBRICANT



Size (gms)
100
250
500
1000

PAN CONNECTOR

Pan connectors are used to bridge gap between WC pan outlet & soil waste pipe. Pan connectors are flexible and provide safe and secure connection between the PAN outlet and soil pipe. PAN connectors are made up of synthetic material and end fitted with a flexible TPE seal. TPE end seal connection of PAN connector ensures watertight connection into soil waste pipe and retain water seals intact by keeping WC free from bacteria and bad odours.

PAN CONNECTORS COMES WITH FOLLOWING THREE DIFFERENT OPTIONS:



PAN CONNECTOR - STRAIGHT

Straight PAN connectors are used when there are marginal few millimeter misalignments between Pan Outlet and soil waste pipe.

Straight Pan Connector available size: 125 X 110mm



PAN CONNECTOR - OFFSET

Offset pan connectors are used when there is misalignment more than few millimeters. Offset Pan Connectors comes with 18mm and 40mm offset. Offset Pan Connectors are always connected with WC pan with downward position.

Offset Pan Connector available size: 125 X 110mm

Note: - Never use offset pan connectors with upward position.



PAN CONNECTOR - COLLAPSIBLE

Collapsible Pan Connectors are used when the distance between PAN outlet and Soil waste pipe is more. They can be used to form a bridge of 265mm to 515mm distance between the PAN outlet and Soil pipe by simply stretching/extending it.

Collapsible Pan Connector available size: 125 X 110mm

QUALITY TEST

In order to assure a high and consistent quality level, PRINCE ULTRAFIT uPVC products undergo strict quality control at every stage of their realization. The company has established a laboratory with modern testing equipment's, which are handled by highly skilled and technicians.

1. ACCEPTANCE TESTS

a. Incoming Inspection & Testing of

- Raw material apparent bulk density, flow time, sieve analysis, VCM content & thermal stability by congo red method
- Rubber parts for surface finish, visual appearance, dimensions, practical fitment & shore A hardness

b. In-process Inspection & Testing of

- Pipes & fittings for visual appearance, dimension & socket fitment with gauges.

c. Final Inspection & Testing of

- Pipes for visual, reversion test, stress relief test, impact test, tensile strength, axial shrinkage test & water tightness test
- Fittings for colour, dimensions, workmanship, visual appearance, stress relief test, sulphated ash content test, drop test & water tightness test.

2. TYPE TESTS

- Pipes & fittings for vicat softening temperature & resistance to sulphuric acid
- Pipes for effect of sunlight & resistance to dichloromethane at specified temperature.
- Fittings for titanium dioxide content.

THERMAL MOVEMENT AND PIPE SUPPORT

The coefficient of linear expansion for uPVC is 0.06mm/m/°C. Like all thermoplastic materials Ultrafit piping system also undergoes to thermal expansion & contraction effect due to atmospheric temperature & internal fluid effluent temperature. Suppose when a 3.0 meter Ultrafit pipeline is subjected to a 25°C temperature variation as a result pipe length will increase by approximately 4.5mm. Therefore, it is important to ensure that the movement is controlled and ring fit joints are installed to accommodate any expansion that may occur due to increase in ambient temperature or hot water internal discharge. Hence while performing installation at site an expansion gap of between 5.0 - 10.0 mm should be allowed within each ring fit socket at each full length of pipe installed.

PRINCE Pipe support clip shall provide efficient and reliable soil discharge system performance hence care has to be taken to place pipe support clip on regular interval. Particularly this is very important for high rise buildings soil discharge system.

SUPPORT SPACING

PRINCE uPVC ULTRAFIT System must be adequately supported by providing support brackets according to its size as shown in below table "Pipe support". As like other material uPVC EASYFIT system also expands & contract with change in temperature. Hence proper care has to be taken care during design stage for expansion and contraction. Also ensure that pipe support bracket shall not restrict the thermal movement of pipe.

PIPE SUPPORT

Pipe size nominal diameter (mm)	40	50	63	75	90	110	160	200
Maximum horizontal spacing (meter)	0.5	0.5	0.7	0.8	1.0	1.0	1.2	1.8
Maximum vertical spacing (meter)	1.2	1.2	1.5	2.0	2.0	2.0	2.0	2.5

uPVC IS GENERALLY INERT TO MOST MINERAL ACIDS, ALKALIES & SALTS PLEASE REFER CHEMICAL RESISTANCE CHART FOR uPVC.

PLEASE NOTE THAT uPVC PIPING SYSTEMS ARE NOT SUITABLE FOR ESTERS, KETONES ETHERS AND AROMATIC OR CHLORINATED HYDROCARONS.

VENT WITH VERTICAL STACK

Why venting is important in SWR system?

Example, suppose if you try to quickly empty a plastic jar having a narrow mouth, jar will empty slowly with gurgle & plug. Now open the vent cap provided on plastic jar, now liquid flows smoothly & fast. This is because of vent hole of jar allow air to enter behind the flowing liquid, producing a quick plug free flow. That's how vent stack is important with drainage vertical stack in drainage system.

The air pressure in drainage stack is same through up and down the stack. When water flow moves through pipe, it compresses the air ahead of it, creating a positive pressure. The pressure build up in drainage stack must be released somehow or the positive pressure will push back on the water. If the air were allowed to push back, this would cause the waste water to back up through the plumbing fixture seals and come out of drain with a bad odor.

Similarly, if the air is not replaced which is behind the water as it moves, it would create negative pressure which cause sucking the water out of the traps.

Hence planning of vent at strategic location is necessary and important to prevent both negative and positive pressure phenomenon in drainage stack.

HANDLING, STORAGE AND TRANSPORTATION

1. Do not handle pipe carelessly during unloading, shifting, jointing practices etc. This may cause permanent damage to the pipe.
2. Do not drag or drop the pipe while unloading, shifting, etc.
3. Store the pipes on flat surface under covered area, ensure that storage place shall not have sharp object, stones etc.
4. Pipes may be stored on timber support of at least 75mm width & breadth, placed at the interval of 1.2 meters.
5. While stacking socketed pipes, stack the pipe with socket protruding at alternate ends.
6. A flat bodied vehicle is ideal for transporting pipes.
7. A timber support of 75mm width & breadth is recommended below the bottom layer pipes in vehicle at a distance of 1.2 meter interval incase of uneven base of the vehicle body.
8. Layer of pipes with integral socket shall be placed with socket protruding alternately.
9. If vehicle is to be loaded with mix load of different dia. & types of pipes, higher diameter pipe shall be placed at bottom.
10. Ensure that pipe should not overhang the vehicle body.

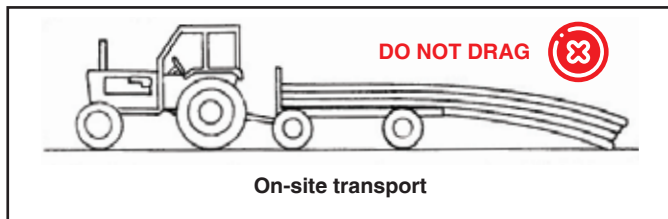
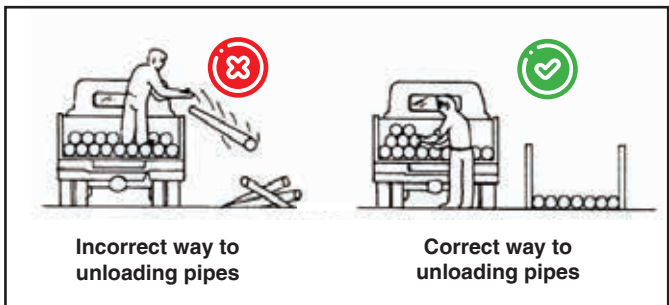
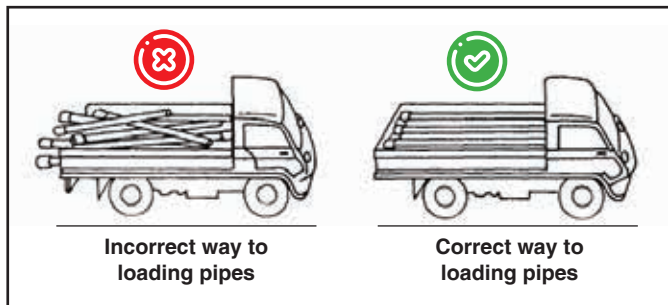

FEW IMPORTANT DESIGN PRINCIPLES

BS EN 12056 "Gravity drainage system inside building" & Part 2 of this standard specifies about minimum design requirement for internal building sanitary drainage system.

1. Drainage shall be provided for all water supply points inside a building.
2. All appliances connected to discharge system shall be installed with a trap to prevent escape of foul gases into the building.
3. The depth of water seal in trap shall not be less than 50mm.
4. The nominal diameter of discharge pipe shall not be reduced in the direction of flow.
5. Vertical stack internal diameter should not be less than the largest trap outlet diameter which is discharging into stack.
6. Vent is must for every sanitary vertical stack system hence provision of adequate size of vent is must to discharge waste water faster and quicker.
Entire Sanitary system shall be properly ventilated from starting point to final point of discharge.
Vent pipe internal cross section area shall have completely open from top to bottom to facilitate exist of foul gases And exit of vent pipe shall be at least 1.5 meter above the roof level.
7. We recommend the use of air admittance valve in sanitary system but they shall comply with pr EN 12860 and shall be of adequate size and as defined in to standard.
8. For multistory building with up to 5 floors the lowest branch connection with stack should be at least 750mm above the invert of horizontal stack line.
9. At the base/bottom of stack provide 90° long radius bend or 2 nos. 45° bend with a short piece of pipe. Also wherever there is change in of direction or offset occurs adopt the same principle.
10. Offset in stack shall be avoided, if not possible use 2 nos. 45° bend with a socketed pipe to connect 2 nos. offset drainage stack.
Ensure vent stack shall be connected with vertical drainage stack both offset to avoid absence of vent.
11. To avoid cross flow in vertical stack the discharge from a larger diameter branch connection into smaller diameter branch, connect smaller diameter branch above the larger diameter branch connection or connect them at right angle or at less than right angle or at least 200mm below.
Similar rule is to be applied to smaller/smaller diameter branch connection.
12. Adequate provision shall be made for access using access fitting for testing and maintenance of system. Access points are necessary for cleaning and clearing any obstructions whenever needed.
13. Generally bath and basin are connected to combine waste pipe, connect basin waste connection with combined waste using Y connection fitting to ensure basin flow in combined branch with flow direction.
Combined waste pipe diameter should be increased where waste from two appliances meets combined waste pipe.
Ensure combine waste discharge pipe length shall be less than 3.0 meter. If it is more provide more gradient to combined discharge pipe.
14. Use hole saw cutter to open closed boss connection socket connection.

TESTING THE INSTALLATION

After completion of soil & waste water piping system, the system shall be ascertained for water tightness using water test at site. We do not recommend smoke test as it may affect adversely with system components.

Usually water testing is done section wise in the soil & waste water system before concealing them. The section of soil & waste system which need to be tested, the open ends are closed using end plugs & end caps. Each section of system shall be tested with 5 meter of water column which is equivalent to 0.5 Kg/cm² hydrostatic pressures. Test is to be carried out for at least 15 minutes. If no leakage found means system is free from leakage.

JOINTING TECHNIQUES OF PRINCE uPVC SWR SYSTEMS

All the SWR system pipes and fittings are manufactured with one end ring fit socket OR solvent weld socket and other plain end which is called as spigot with chamfer of 150. Chamfer provided on spigot helps in making easy entry of pipe in socket seal as well as protects seal from damage.

WITH RING FIT SOCKET

Ring fit sockets joints are provided with factory fitted composite sealing rings (CSR). Composite sealing rings are manufactured using dual component injection moulding technique. These CSR are designed and manufactured in such a way to fit socket groove properly with low assembly jointing force. CSR is made with two injection moulding materials i.e. polypropylene and thermoplastic elastomer rubber which are bonded with each other. Thermoplastic rubber provides good seal against the pipe and polypropylene supporting ring firmly hold CSR in rubber groove. Composite sealing ring provides higher stability, better sealing performance and lifetime durability. In ring fit socket jointing process solvent cement is not needed hence joint can be dismantled & assemble at any time. CSR are suitable for continuous flow up to 60°C and intermittent flow up to 90°C in drainage, sewerage and rain water discharge systems. In ring fit joint thermal expansion and compensation taken care easily due to free movement of pipe in composite sealing ring.



Composite Sealing Ring

WITH SOLVENT WELD SOCKET

As the name, Solvent weld socket joints are made with the help of solvent cement without using sealing ring. Socket dimensions of solvent weld socket pipes and fitting are designed accordingly that keeping minimal gap between socket and pipe wall. This gap is filled with PVC solvent cement. As the jointing is done in solvent weld socket using solvent cement, the joint becomes permanent joint. If needs to open joint in this case then pipe and fitting need to be cut with hack saw or carpenter saw and new pipe and fittings to be used for making reconnection. Since solvent joint is permanent thermal expansion and compensation is controlled by providing expansion loop at specific interval in longer pipe length.

ADVANTAGES OF RING FIT JOINTS

- Complete Leak free joint.
- Simple and quick installation joint.
- Reduced installation time and hence saving on installation cost.
- Joints can be re-opened and assemble again.
- Composite sealing rings are factory fitted.
- Apply rubber lubricant on chamfer portion and perform joint within a minute.
- Thermal expansions in pipe are easily compensated due to sliding in sealing ring.

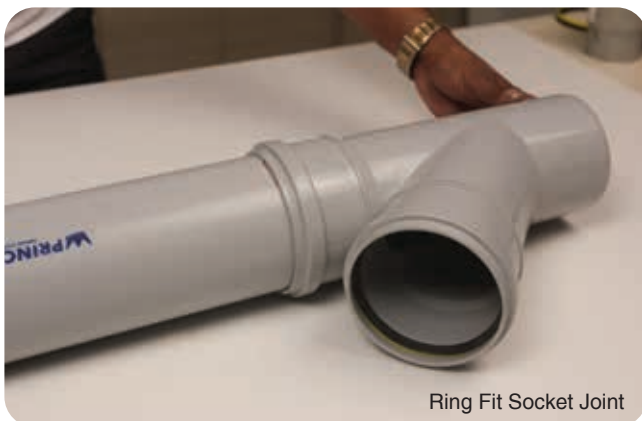

Ring Fit Socket Joint



Solvent Socket Joint

SWR PIPING SYSTEMS ARE AN EFFECTIVE SOLUTION FOR SOIL, WASTE AND RAINWATER

JOINTING METHODS

PROCESS: Rubber Ring Joint

DOs



CUTTING

It is imperative to mark the pipe from all sides so that pipe is cut with the help of a Hand Saw. It should be a right angle cut from all the sides. The cut piece should not be with burr on edge.



DON'ts



CUTTING

Do not cut slant/ unevenly.



CHAMFERING

(This step is required when pipe cutting is done from 3 mtr pipe to any required length during installation) After cutting, the pipe needs to be chamfered from the outer sides of the pipe. It is advisable to provide approximately 2 mm wide, 15° chamfer on pipe end.



CHAMFERING

Do not proceed with installation of pipe without chamfering.

DEBURRING AND RIDGE REMOVAL

Remove all the burrs and ridges accumulated on the inner as well as the outer edges of the pipe with the help of a deburring knife, file or abrasive paper.



DEBURRING AND RIDGE REMOVAL

Do not proceed with the installation of pipe without deburring.



CLEANING

Thoroughly clean the pipe with dry cloth where the solvent cement is going to be applied to avoid dust, dirt, oil, moisture and other foreign materials during the installation process.



CLEANING

Do not join the pipes without cleaning the pipe ends.

DOs



DRYFIT TEST

Before applying solvent cement, insert the pipe end into the socket of the next pipe or fitting to check that interference occurs at about 1/3 to 2/3 of the socket depth.



APPLICATION OF LUBRICANT

Mark the pipe length to be inserted for jointing. Apply a liberal coat of lubricant for easy and smooth insertion.



JOINTING

Push the pipe inside the fitting till marked end is completely inserted equally from all sides.



LEAKAGE TEST

Leakage tests may be carried out at 0.5 kg/cm² pressure for 15 minutes.

INSTALLATION AND COMMISSIONING

- Pipe line should be installed in proper alignment and along with necessary clamps.
- Pressure tests may be carried out at 0.5 kg/cm² pressure for 15 minutes.

DON'ts



DRYFIT TEST

Do not apply solvent cement without dryfit test.

APPLICATION OF LUBRICANT

Do not insert the pipe and fitting without lubrication.



JOINTING

Do not use a hammer or half push the pipe.



LEAKAGE TEST

Ensure proper alignment and avoid use of damaged rubber rings if any.

INSTALLATION AND COMMISSIONING

- Avoid loose joints & misalignment.
- Pressure testing should not be done before 24 hrs of curing.

JOINTING METHODS

PROCESS: Solvent Joint

DOs



CUTTING

It is imperative to mark the pipe from all sides so that pipe is cut with the help of a Hand Saw. It should be a right angle cut from all the sides. The cut piece should not be with burr on edges.



CHAMFERING

(This step is required when pipe cutting is done from 3 mtr pipe to any required length during installation) After cutting, the pipe needs to be chamfered from the outer sides. It is advisable to provide an approximately 2 mm wide, 15° chamfer on spigot end.



DEBURRING AND RIDGE REMOVAL

Remove all the burrs and ridges accumulated on the inner as well as the outer edges of the pipe with the help of a deburring knife, file or abrasive paper.



CLEANING

Thoroughly clean the pipe with dry cloth where the solvent cement is going to be applied to avoid dust, dirt, oil, moisture and other foreign materials during the installation process.



DON'ts



CUTTING

Do not cut slant/ unevenly.



CHAMFERING

Do not proceed with installation of pipe without chamfering.

DEBURRING AND RIDGE REMOVAL

Do not proceed with the installation of pipe without deburring.



CLEANING

Do not join the pipes without cleaning the pipe ends.

DOs



DRYFIT TEST

Before applying solvent cement, insert the pipe end into the socket of the next pipe or fitting to check that interference occurs at about 1/3 to 2/3 of the socket depth.



APPLICATION OF SOLVENT CEMENT

Mark the pipe length to be inserted for jointing. Apply a liberal coat of solvent cement with the help of the brush on the marked surface.



JOINTING

Push the pipe inside the fitting / pipe so that it goes inside equally from all the sides. Wipe off excess solvent cement that comes out from all the edges. Hold the joint for one to two minutes so that the jointing is perfect.



INSTALLATION AND COMMISSIONING

- Pipe line should be installed in proper alignment & along with necessary clamps.
- Pressure testing may be carried out after a curing period of 24 hrs.

DON'ts



DRYFIT TEST

Do not apply solvent cement without dryfit test.

APPLICATION OF SOLVENT CEMENT

Do not apply excess solvent cement on the pipe and do not use solvent cement by hand.

JOINTING

Do not use a hammer or half push the pipe.

INSTALLATION AND COMMISSIONING

- Avoid loose joints & misalignment.
- Pressure testing should not be done before 24 hrs of curing.

CHEMICAL RESISTANCE CHART OF uPVC

Chemical	23°C (73°F)	60°C (140°F)
A		
Acetaldehyde	N	N
Acetaldehyde, aq 40%	C	N
Acetamide - -	-	-
Acetic acid, vapor	R	R
Acetic acid, glacial	R	N
Acetic acid, 25%	R	R
Acetic acid, 60%	R	N
Acetic acid, 85%	R	N
Acetic anhydride	N	N
Acetone	N	N
Acetylene	N	N
Acetyl chloride	N	N
Acetylnitrile	N	N
Acrylonitrile	N	N
Acrylic acid	N	N
Adipic acid	R	R
Alcohol, allyl	R	C
Alcohol, amyl	N	N
Alcohol, benzyl	N	N
Alcohol, butyl (n-butanol)	R	R
Alcohol, diacetone	N	N
Alcohol, ethyl (ethanol)	R	R
Alcohol, hexyl (hexanol)	R	R
Alcohol, isopropyl (2-propanol)	R	R
Alcohol, methyl (methanol)	R	R
Alcohol, propyl (1-propanol)	R	R
Alcohol, propargyl	R	R
Allyl chloride	N	N
Alums	R	R
except Aluminim fluoride	R	N
Ammonia, gas	R	R
Ammonia, liquid	N	N
Ammonium salts	R	R
except Ammonium Dichromate	R	N
Ammonium fluoride, 10%	R	R
Ammonium fluoride, 25%	R	C
Amyl acetate	N	N

Chemical	23°C (73°F)	60°C (140°F)
Amyl chloride	N	N
Aniline	N	N
Aniline chlorohydrate	N	N
Aniline hydrochloride	N	N
Anthraquinone	R	R
Antimony trichloride	R	R
Anthraquinone sulfonic acid	R	R
Aqua regia	C	N
Arsenic acid, 80%	C	N
Aryl-sulfonic acid	R	R
B		
Barium salts	R	R
except Barium nitrate	R	N
Beer	R	R
Beet sugar liquor	R	R
Benzaldehyde, 10%	R	N
Benzene (benzol)	R	N
Benzene sulfonic acid, 10%	R	R
Benzene sulfonic acid, > 10%	N	N
Benzoic acid	R	R
Black liquor – paper	R	R
Bleach, 12% active chlorine	R	R
Bleach, 5% active chlorine	R	R
Borax	R	R
Boric acid	R	R
Brine	R	R
Bromic acid	R	R
Bromine, aq	R	R
Bromine, liquid	N	N
Bromine, gas, 25%	R	R
Bromobenzene	N	N
Bromotoluene	N	N
Butadiene	R	R

R - Generally Resistant

C - Less resistant than R but still suitable for some conditions

N - Not resistant

CHEMICAL RESISTANCE CHART OF uPVC

Chemical	23°C (73°F)	60°C (140°F)
Butane	R	R
Butynediol	R	N
Butyl acetate	N	N
Butyl stearate	R	N
Butyl phenol	R	N
Butylene, liquid	R	R
Butyric acid	R	N
C		
Cadmium Cyanide	R	R
Calcium salts	R	R
except Calcium bisulde	N	N
Calcium hypochlorite, 30%	R	R
Calcium hydroxide	R	R
Calcium Nitrate	R	R
Calcium Oxide	R	R
Calcium Sulfate	R	R
Camphor	R	N
Cane sugar liquors	R	R
Carbon disulfide	N	N
Carbon dioxide	R	R
Carbon dioxide, aq	R	R
Carbon monoxide	R	R
Carbitol	R	N
Carbon tetrachloride	R	N
Carbonic Acid	R	R
Castor oil	R	R
Caustic potash (potassium hydroxide),50%	R	R
Caustic soda (sodium hydroxide), <40%	R	R
Cellosolve	R	N
Cellosolve acetate	R	N
Chloral hydrate	R	R
Chloramine, dilute	R	N
Chloric acid, 20%	R	R
Chlorine, gas, dry	C	N
Chlorine, gas, wet	N	N
Chlorine, liquid	N	N
Chlorine water	R	R
Chloracetic acid, 50%	R	R

Chemical	23°C (73°F)	60°C (140°F)
Chloroacetyl Chloride	R	N
Chlorobenzene	N	N
Chlorobenzyl chloride	N	N
Chloroform	N	N
Chloropicrin	N	N
Chlorosulfonic acid	R	N
Chromic acid, 10%	R	R
Chromic acid, 30%	R	R
Chromic acid, 40%	R	C
Chromic acid, 50%	N	N
Chromium potassium sulfate	R	N
Citric acid	R	R
Coconut oil	R	R
Coffee	R	R
Coke oven gas	R	R
Copper acetate	R	N
Copper salts, aq	R	R
Corn oil	R	R
Corn syrup	R	R
Cottonseed oil	R	R
Cresote	N	R
Cresol, 90%	N	N
Cresylic acid, 50%	R	R
Croton aldehyde	N	N
Crude oil, sour	R	R
Cupric Salts, aq	R	R
Cyclohexane	N	N
Cyclohexanol	N	N
Cyclohexanone	N	N
D		
Detergents, aq	R	R
Dextrin	R	R
Dextrose	R	R
Dibutoxyethyl phthalate	N	N
Diesel fuels	R	R
Diethylamine	N	N
Diethyl Ether	R	N
Disodium phosphate	R	R

SWR PIPING SYSTEMS ARE AN EFFECTIVE SOLUTION FOR SOIL, WASTE AND RAINWATER

CHEMICAL RESISTANCE CHART OF uPVC

Chemical	23°C (73°F)	60°C (140°F)
Diglycolic acid	R	R
Dioxane -1,4	N	N
Dimethylamine	R	R
Dimethyl formamide	N	N
Dibutyl phthalate	N	N
Dibutyl sebacate	R	N
Dichlorobenzene	N	N
Dichloroethylene	N	N
E		
Ether	N	N
Ethyl ether	N	N
Ethyl halides	N	N
Ethylene halides	N	N
Ethylene glycol	R	R
Ethylene oxide	N	N
F		
Fatty acids	R	R
Ferric salts	R	R
Fish Oil	R	R
Fluorine, dry gas	R	N
Fluorine, wet gas	R	N
Fluoboric acid	R	R
Fluosilicic acid, 50%	R	R
Formadehyde	R	R
Formic acid	R	N
Freon - F11, F12, F113, F114	R	R
Freon - F21, F22	R	N
Fructose	R	R
Furfural	N	N
G		
Gallic acid	R	R
Gas, coal, manufactured	N	N
Gas, natural, methane	R	R
Gasolines	C	C
Gelatin	R	R
Glucose	R	R
Glue, animal	R	R
Glycerine (glycerol)	R	R

Chemical	23°C (73°F)	60°C (140°F)
Glycolic acid	R	R
Glycols	R	R
Grape Sugar	R	R
Green liquor, paper	R	R
H		
Heptane	R	R
Hexane	R	N
Hexanol	R	R
Hydraulic Oil	R	N
Hydrobromic acid, 20%	R	R
Hydrochloric acid	R	R
Hydrofluoric acid, 30%	R	N
Hydrofluoric acid, 50%	R	N
Hydrofluoric acid, 100%	N	N
Hydrofluosilic acid	R	R
Hydrocyanic acid	R	R
Hydrogen	R	R
Hydrogen cyanide	R	R
Hydrogen fluoride	N	N
Hydrogen phosphide	R	R
Hydrogen peroxide, 50%	R	R
Hydrogen peroxide, 100%	R	R
Hydrogen sulfide, aq	R	R
Hydrogen sulfide, dry	R	R
Hydroquinone	R	R
Hydroxylamine sulfate	R	R
Hydrazine	N	N
Hypochlorous acid	R	R
I		
Iodine, aq, 10%	N	N
J		
Jet fuels, JP-4 and JP-5	C	C

R - Generally Resistant

C - Less resistant than R but still suitable for some conditions

N - Not resistant

CHEMICAL RESISTANCE CHART OF uPVC

Chemical	23°C (73°F)	60°C (140°F)
K		
Kerosene	R	R
Ketones	N	N
Ketchup	R	N
Kraft paper liquor	R	R
L		
Lactic acid, 25%	R	R
Lactic acid, 80%	R	N
Lard oil	R	R
Lauric acid	R	R
Lauryl acetate	R	R
Lauryl chloride	R	R
Lead salts	R	R
Lime sulfur	R	R
Linoleic acid	R	R
Linoleic oil	R	R
Linseed oil	R	R
Liqueurs	R	R
Lithium salts	R	R
Lubricating oils	R	R
M		
Magnesium salts	R	R
Maleic acid	R	R
Malic acid	R	R
Manganese sulfate	R	R
Mercuric salts	R	R
Mercury	R	R
Methane	R	R
Methoxyethyl oleate	R	N
Methyl acetate	N	N
Methyl amine	N	N
Methyl bromide	N	N
Methyl cellosolve	N	N
Methyl chloride	N	N
Methyl chloroform	N	N
Methyl ethyl ketone	N	N
Methyl isobutyl carbinol	N	N
Methyl isopropyl ketone	N	N

Chemical	23°C (73°F)	60°C (140°F)
Methyl methacrylate	R	N
Methyl sulfate	R	N
Methyl sulfuric acid	R	R
Methylene bromide	N	N
Methylene chloride	N	N
Methylene iodide	N	N
Milk	R	R
Mineral oil	R	R
Molasses	R	R
Monochloroacetic acid	R	R
Monochlorobenzene	N	N
Monoethanolamine	N	N
Motor oil	R	R
N		
Naptha	R	R
Naphthalene	N	N
Natural Gas	R	R
Nickel acetate	R	N
Nickel salts	R	R
Nicotine	R	R
Nicotinic acid	R	R
Nitric acid, 0 to 40%	R	R
Nitric acid, 50%	R	C
Nitric acid, 100%	N	N
Nitrobenzene	N	N
Nitroglycerine	N	N
Nitrous acid, 10%	R	R
Nitrous oxide, gas	R	N
Nitroglycol	N	N
O		
Oleic acid	R	R
Oleum	N	N
Olive oil	R	R
Oxalic acid	R	R
Oxygen, gas	R	R
Ozone, gas	R	R

CHEMICAL RESISTANCE CHART OF uPVC

Chemical	23°C (73°F)	60°C (140°F)
P		
Palmitic acid, 10%	N	N
Palmitic acid, 70%	R	N
Paraffin	R	R
Pentane	C	C
Peracetic acid, 40%	R	N
Perchloric acid, 15%	R	N
Perchloric acid, 70%	R	N
Perchloroethylene	R	N
Perphosphate	R	N
Phenol	R	N
Phenylhydrazine	N	N
Phosphoric anhydride	R	N
Phosphoric acid	R	R
Phosphorus pentoxide	R	N
Phosphorous trichloride	N	N
Photographic chemicals, aq	R	R
Phthalic acid	N	N
Plating solutions, metal	R	R
Potash	R	R
Potassium amyl xanthate	R	N
Potassium salts, aq	R	R
except Potassium iodide	R	N
Potassium permanganate, 10%	R	R
Potassium permanganate, 25	R	N
Propane	R	R
Propylene dichloride	N	N
Propylene oxide	N	N
Pyridine	N	N
Pyrogallic acid	R	N
R		
Rayon coagulating bath	R	R
S		
Salicylic acid	R	R
Salicyladehyde	N	N
Selenic acid, aq.	R	R
Silicic acid	R	R
Silicone oil	R	N

Chemical	23°C (73°F)	60°C (140°F)
Silver salts	R	R
Soaps	R	R
Sodium salts, aq	R	R
except Sodium chlorite	N	N
except Sodium chlorate	R	N
except Sodium hypochlorite	R	N
Stannic chloride	R	R
Stannous chloride	R	R
Starchy	R	R
Stearic acid	R	R
Stoddard solvent	N	N
Succinic acid	R	R
Sulfamic acid	N	N
Sulfate & Sulfite liquors	R	R
Sulfur	R	R
Sugars, aq	R	R
Sulfur dioxide, dry	R	R
Sulfur dioxide, wet	R	N
Sulfur trioxide, gas, dry	R	R
Sulfur acid, wet	R	N
Sulfuric acid, up to 80%	R	R
Sulfuric acid, 90 to 93%	R	N
Sulfuric acid, 94 to 100%	N	N
Sulfurous acid	R	R
T		
Tall oil	R	R
Tannic acid	R	R
Tanning liquors	R	R
Tar	N	N
Tartaric acid	R	R
Terpineol	C	C
Tetrachloroethane	C	C
Toluene	N	N

R - Generally Resistant

C - Less resistant than R but still suitable for some conditions

N - Not resistant

CHEMICAL RESISTANCE CHART OF uPVC

Chemical	23°C (73°F)	60°C (140°F)
Tomato juice	R	R
Transformer oil	R	R
Tributyl phosphate	N	N
Tributyl citrate	R	R
Trichloroacetic acid	R	R
Trichloroethylene	R	N
Triethanolamine	R	N
Triethylamine	R	R
Trimethyl propane	R	N
Trisodium phosphate	R	R
Turpentine	R	R
U		
Urea	R	R
Urine	R	R

Chemical	23°C (73°F)	60°C (140°F)
V		
Vaseline	N	N
Vegetable oils	R	R
Vinegar	R	R
Vinyl acetate	N	N
W		
Water, deionized	R	R
Water, distilled	R	R
Water, salt	R	R
White Liquor	R	R
Whiskey	R	R
Wines	R	R
X		
Xylene	N	N
Z		
Zinc salts	R	R

WARRANTY

PRINCE PIPES AND FITTINGS LIMITED warrants to the original owner of the structure in which its Ultrafit SWR Pipe and Fittings have been installed, that the Products will be free from manufacturing defects and conform to applicable standards under normal use. Buyer's remedy for breach of this warranty is limited to replacement of, or credit for, the defective product. This warranty excludes any expense for removal or reinstallation of any defective product and any other incidental, consequential, or punitive damages.

This limited warranty is the only warranty made by seller and is expressly in lieu of all other warranties, express and implied, including any warranties of merchantability and fitness for a particular purpose.

No statement, conduct or description by Prince Pipes or its representative, in addition to or beyond this Limited Warranty, shall constitute a warranty. This Limited Warranty may only be modified in writing signed by an officer of Prince Pipe.

This Limited Warranty will not apply if:

1. The Products are used for purposes other than the transmission of domestic water.
2. The Products are not installed in good and workmanship consistent with normal industry standards; installed in compliance with the latest instructions published by Prince Pipes and good plumbing practices; and installed in conformance with all applicable plumbing and building code requirements.
3. Products of Prince Pipes are used with the products of other manufacturers.
4. The Products fail due to normal wear and tear or deficiencies in design, engineering, or installation of the water distribution system of which they are a part.
5. The Products have been the subject of modification; misuse; misapplication; improper maintenance or repair; damage caused by the fault or negligence of anyone other than Prince Pipe; or any other act or event beyond the control of Prince Pipes.
6. Improper storage, failure to observe the operating instructions, over stressing or overloading, unsuitable operating media, unsuitable construction work or unsuitable building ground.
7. The Products fail due to the freezing of water in the Products.
8. The Products fail due to contact with incompatible material list provided below.
9. Prince Pipe cannot accept responsibility for the performance, dimensional accuracy, or compatibility of pipe, fittings, gaskets, or couplings not manufactured or sold by Prince Pipes.
10. This Limited Warranty will not apply unless written notice of a claim is mailed to Prince Pipes at the address below within 30 days of the day of discovery of the allegedly defective product. Any Prince Pipes products alleged to be defective must be made available to Prince Pipes at the following address for verification, inspection and determination of cause:

PRINCE PIPES AND FITTINGS LIMITED

The Ruby, 8th Floor, 29, Senapati Bapat Marg (Tulsi Pipe Road), Dadar (W), Mumbai - 400 028, Maharashtra, India.

Purchaser must obtain a return materials authorization and instructions for return shipment to Prince Pipes of any product claimed defective or shipped in error. Any Prince Pipes product proved to be defective in manufacture will be replaced F.O.C. point of original delivery, or credit will be issued, at the discretion of Prince Pipes.

AUTHORISED DISTRIBUTOR :



Whatsapp No. +91-91670 39334

www.princeenterprise.co.in

PRINCE ENTERPRISE

Add: Kasturi Complex, Gala No.K-1, Anjur Road Rahnal Village, Bhiwandi, Dist - Thane - 421302,

Office No. +91-7410078051 / 52 / 53.

Email: princeenterprise1@gmail.com