

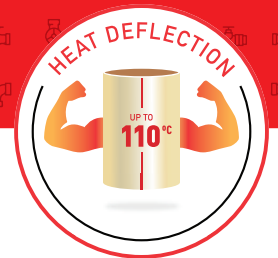

WORLD'S **NO.1\*** CPVC  
PLUMBING SYSTEMS

TECHNICAL MANUAL



**FLOWGUARD® PLUS**  
CPVC PLUMBING SYSTEMS™

FLOWGUARD® is the registered mark of The Lubrizol Corporation. The Lubrizol Corporation is a Berkshire Hathaway Company. \*FlowGuard CPVC is No.1 based on the length of pipes installed.

# **PRINCE**<sup>®</sup> PIPING SYSTEMS



**ZERO DEFECT  
CHOICE**



# Greener Better Together



Prince Pipes is not about creating products that are different but providing solutions that make a difference. From our zero defect manufacturing process that involves using recycled plastic to designing and equipping our plants with solar panels and various other energy saving manufacturing techniques, our endeavor has always been to further bring down the emission levels. Our strong belief in the concept of "better lasts longer" has not only helped us deliver premium quality products but also ensure lesser consumption. Together with our channel partners and plumbers, we are sure to leave a strong legacy for the generations to come.

## THE JOURNEY

- 
- 2021**

    - Manufacturing unit commissioned at Sangareddy, Telangana, to strengthen our strategic presence in Southern India
    - Prince Pipes awarded "Brand of The Year - Pipes" at Realty + INEX Awards 2021
  - 2020**

    - Prince Pipes Product collaborates with Lubrizol, the world's largest manufacturers and inventors of CPVC compounds
    - Technical collaborates with Tooling Holland, a global leader in plastic moulds manufacturing
  - 2019**

    - Manufacturing unit at Jobner, Rajasthan to cater to increasing volume demand
    - Company successfully listed on BSE and NSE
  - 2018**

Prince Pipes announced bollywood actor Akshay Kumar as its brand ambassador.
  - 2017**

    - Prince Pipes became a Public Limited Company.
    - "Economic Times Polymers Award (Excellence in Plastics)" for excellence in building and construction (plumbing) in the large enterprises category
  - 2016**

Mr. Parag Chheda presented with the "Inspiring Business Leader Award" by Economic Times
  - 2015**

    - Mr. Jayant Chheda received the "Lifetime Achievement Award" at Vinyl India Conference
    - "IMEA Award" for the Haridwar factory by Frost & Sullivan
  - 2014**

Prince Pipes received "Asia's Most Promising Brand Award" by World Consulting and Research Corporation Delhi
  - 2012**

Prince Pipes acquired "Trubore"- a renowned brand of southern India from Chemplast Sanmar Group along with their two manufacturing units at Kolhapur & Chennai
  - 2010**

    - Winner of "Best SME" at the Emerging India Awards 2010 by ICICI Bank, CNBC TV 18 & CRISIL
    - Winner of "Outstanding Quality Contribution In Pipes Sector" by Bloomberg EPC world
  - 2008**

Manufacturing unit established at Haridwar (Uttarakhand) to cater to the increasing demand for Prince Pipes products
  - 2005**

Prince Pipes achieved the ₹100 Crore benchmark
  - 2000**

Manufacturing unit established at Dadra (Silvassa - D & N.H) to augment the pipe manufacturing capacity by setting up a new extrusion unit
  - 1998**

ISO Certification earned by ensuring compliance to every step of the quality management system
  - 1995**

Manufacturing unit established at Athal (Silvassa-D & N.H) to set-up a large scale Injection Moulding Unit which marked the beginning of Prince Pipes being one of the market leaders in PVC Fittings
  - 1987**

    - Mr. Jayant Chheda commenced manufacturing unit of PVC Products
    - 1st PVC Fittings Manufacturing Unit initiated to provide total piping solutions

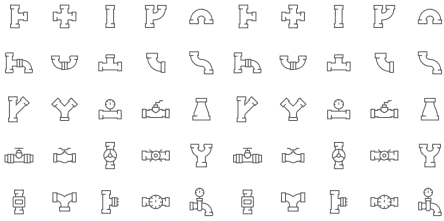

# CONTENTS

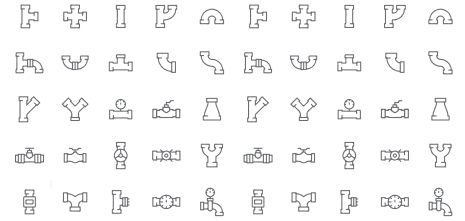

**01**

Manufacturing units

**02**

Certifications & Awards

**03**

Prince + Tooling Holland

**04**

Trusted by the world,  
brought to you by Prince

**05**

CPVC the preferred choice

**06**

The 'Plus' In  
Prince Flowguard Plus

**07**

Basic properties of  
Prince Flowguard Plus CPVC

**08**

Standards, codes &  
working pressure

**09**

Features, benefits & applications

**10**

Pipes dimensions, working pressure  
and derating factor

**11**

Perfect fit advantages &  
threaded fittings

**12**

Fittings dimensions

**24**

Brass insert fittings dimensions

**29**

Solvent cements

**30**

Quality control

**31**

Thermal effects

**32**

Horizontal & vertical spacing

**34**

Fluid handling characteristics

**35**

Pipes friction loss

**37**

- Pressure drop in valves & strainers
- Water hammer & surge pressure

**38**

Solvent cement & handling,  
curing, number of joints

**39**

Basic principle of solvent welding

**40**

Joining procedure

**41**

- Tips for solvent cementing
- Before testing the installation

**42**

- Installation & commissioning
- Handling and storage

**43**

Frequently asked questions

**44**

Warranty & incompatibility



# MANUFACTURING UNITS



**SANGAREDDY EST. 2021**



**JAIPUR EST. 2019**



**KOLHAPUR EST. 2012**



**CHENNAI EST. 2012**



**HARIDWAR EST. 2008**



**DADRA EST. 2000**



**ATHAL EST. 1995**

# CERTIFICATIONS

**Certificate**

Standard: **ISO 9001:2015**  
 Certificate Registr. No: **01 100 2036834/03**

Certificate Holder: **WPRINCE**  
**PRINCE PIPES AND FITTINGS LTD**  
 Survey No.132/11/13 Athal Road,  
 Village Athal,Haroti, Sitrasa- 396235,  
 Dadra & Nagar Haveli, India.

Scope: **Manufacture of uPVC, CPVC and HDPE Fittings.**

Validity: Proof has been furnished by means of an audit that the requirements of ISO 9001:2015 are met. The certificate is valid from 2021-05-28 until 2024-05-27.

2021-05-28

TUV Rheinland Cert GmbH  
 Am Graven Stein 51105 Köln

IAF DAKKS  
 TÜV Rheinland  
 Precisely Right.

www.tuv.com

**Certificate**

Standard: **ISO 9001:2015**  
 Certificate Registr. No: **01 100 2036834/01**

Certificate Holder: **WPRINCE**  
**PRINCE PIPES AND FITTINGS LTD**  
 Bhasara No.1548, 1549, 14 & 15,  
 Salempur, Jalgaon-2, Harwar-248402,  
 Uttarakhand, India.

Scope: **Manufacture of uPVC, CPVC, PPR and HDPE Pipes and Fittings.**

Validity: Proof has been furnished by means of an audit that the requirements of ISO 9001:2015 are met. The certificate is valid from 2021-05-28 until 2024-05-27.

2021-05-28

TUV Rheinland Cert GmbH  
 Am Graven Stein 51105 Köln

IAF DAKKS  
 TÜV Rheinland  
 Precisely Right.

www.tuv.com

**Certificate**

Standard: **ISO 9001:2015**  
 Certificate Registr. No: **01 100 2036834**

Certificate Holder: **WPRINCE**  
**PRINCE PIPES AND FITTINGS LTD**  
 The Ruby, 8th floor, 29, Senapati Bapat Marg (Tulsi Pipe Road), Dadar - West, Mumbai 400028, Maharashtra, India.

Scope: **Design, Development, Marketing, Procurement, Purchase/CAPEX, H.R., Logistics Management and Corporate Support functions.**

Validity: Proof has been furnished by means of an audit that the requirements of ISO 9001:2015 are met. The certificate is valid from 2021-05-28 until 2024-05-27.

2021-05-28

TUV Rheinland Cert GmbH  
 Am Graven Stein 51105 Köln

IAF DAKKS  
 TÜV Rheinland  
 Precisely Right.

www.tuv.com

**Certificate**

Standard: **ISO 14001:2015**  
 Certificate Registr. No: **01 104 2036834**

Certificate Holder: **WPRINCE**  
**PRINCE PIPES AND FITTINGS LTD**  
 The Ruby, 8th floor, 29, Senapati Bapat Marg (Tulsi Pipe Road), Dadar - West, Mumbai 400028, Maharashtra, India.

Scope: **Design, Development, Marketing, Procurement, Purchase/CAPEX, H.R., Logistics Management and Corporate Support functions.**

Validity: Proof has been furnished by means of an audit that the requirements of ISO 14001:2015 are met. The certificate is valid from 2021-05-28 until 2024-05-27.

2021-05-28

TUV Rheinland Cert GmbH  
 Am Graven Stein 51105 Köln

IAF DAKKS  
 TÜV Rheinland  
 Precisely Right.

www.tuv.com

**Certificate**

Standard: **ISO 45001:2018**  
 Certificate Registr. No: **01 213 2036834**

Certificate Holder: **WPRINCE**  
**PRINCE PIPES AND FITTINGS LTD**  
 The Ruby, 8th floor, 29, Senapati Bapat Marg (Tulsi Pipe Road), Dadar - West, Mumbai 400028, Maharashtra, India.

Scope: **Design, Development, Marketing, Procurement, Purchase/CAPEX, H.R., Logistics Management and Corporate Support functions.**

Validity: Proof has been furnished by means of an audit that the requirements of ISO 45001:2018 are met. The certificate is valid from 2021-05-28 until 2024-05-27.

2021-05-28

TUV Rheinland Cert GmbH  
 Am Graven Stein 51105 Köln

IAF DAKKS  
 TÜV Rheinland  
 Precisely Right.

www.tuv.com

**Certificate**

Standard: **ISO 50001:2018**  
 Certificate Registr. No: **01 407 183634/01**

Organization: **Prince Pipes and Fittings Ltd**  
 Karsara No. 1548, 1549 & 15, Salempur, Mehmed - 2, Ind. Ind. Park-2, Harwar 248402 India

Site: **WPRINCE**  
**PRINCE PIPES AND FITTINGS LTD**  
 The Ruby, 8th floor, 29, Senapati Bapat Marg, (Tulsi Pipe Road), Dadar - West, MUMBAI 400028, India

Scope: **Design, Development, Marketing, Procurement, Purchase / CAPEX, H.R., Logistics Management and Corporate Support Functions.**

Validity: Proof has been furnished by means of an audit that the requirements of ISO 50001:2018 are met. The certificate is valid in conjunction with the main certificate 01 407 183634/01 from 2021-05-21 until 2024-05-20.

2021-05-21

TUV Rheinland Cert GmbH  
 Am Graven Stein 51105 Köln

IAF DAKKS  
 TÜV Rheinland  
 Precisely Right.

www.tuv.com

**GRIHA Council**  
 This is to certify that the product of

**"LUBRIZOL ADVANCED MATERIALS INDIA PVT LIMITED"**

**FlowGuard Plus CPVC Pipe**  
 (Advanced Pipes Pvt Limited/ Prince Pipes & Fittings Limited)  
 (under typology innovation)

has been included in the GRIHA Product Catalogue under the following categories:

GRIHA V.3 criterion: 34  
 GRIHA V.2019 criterion: 31  
 &  
 SVAGRIHA criterion: 14

The product can be used in GRIHA & SVAGRIHA registered projects to meet the GRIHA & SVAGRIHA norms, respectively. This is valid only for the product which has been mentioned above.

The certificate for the above mentioned product is valid from 15<sup>th</sup> February 2021 - 14<sup>th</sup> February 2023

Sandeep Seth  
 Chief Executive Officer

www.griha.org

**AWARDS**

**most preferred BUILDING MATERIAL COMPANY (PIPES & FITTINGS) 2022**

**INEX INTERIOR & EXTERIOR AWARDS 2021**

**Realty+**  
 INEX AWARDS 2021

## **INNOVATION TO THE NEXT LEVEL PRINCE PIPES TIES UP WITH TOOLING HOLLAND BV**

---

At Prince Pipes, we believe in non-stop innovation to exceed your expectations.

Our technical tie-up with Tooling Holland is another milestone in this journey.

Tooling Holland brings over 30 years of proven experience in development and production of injection moulds. Their global skillset will further enhance our technical capabilities and operational efficiency. So you always get world-class products.

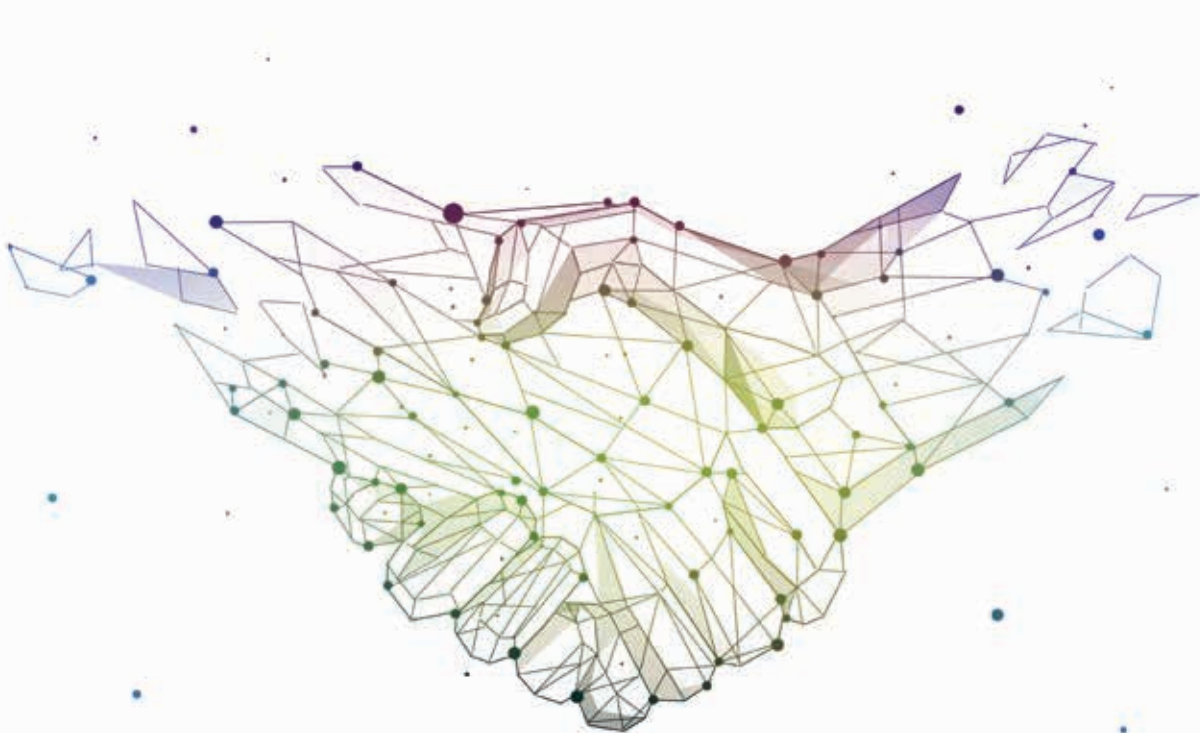



# TRUSTED BY THE WORLD, BROUGHT TO YOU BY PRINCE.

Invented in 1959, used all over the world, established as a trusted product and now brought to you by Prince Pipes, FlowGuard Plus CPVC plumbing systems are built to last for generations. Designed for a service life of 50 years, these CPVC pipes and fittings can withstand temperatures up to 93°C and are ideal for hot and cold water applications. But that's not it. FlowGuard Plus advantage means low bacterial growth and therefore, safe and hygienic water. It is fire retardant and does not support combustion. Moreover, it has high tensile strength, 25% better pressure bearing capacity and unparalleled UV resistance. No wonder, it has won so many accreditations and certifications around the world and is hands down,

the world's NO.1\* CPVC

**FLOWGUARD® PLUS**  
CPVC PLUMBING SYSTEMS™



\*FlowGuard CPVC is No.1 based on the length of pipes installed.



## CPVC THE PREFERRED CHOICE

PROPERTY	PRINCE FLOWGUARD PLUS CPVC	COPPER	GI
Corrosion	High chemical resistance makes it corrosion-free	Over a period of time	Rapid corrosion and deterioration
Scaling, pitting and leaching, full bore flow	Full bore flow, thanks to the absence of scaling, pitting and leaching	Reduced bore flow because of scaling, pitting and leaching	Reduced bore flow because of severe scaling, pitting and leaching
Thermal conductivity	Require reduced insulation as lower thermal conductivity reduces heat loss	Very high - increases heat loss and requires high insulation	Very high thermal conductivity - increases heat loss and requires high insulation
Bacterial growth	Extremely low	Higher than CPVC	Higher than copper
Fire resistance	High LOI of 60 makes it fire-retardant unless exposed to an external fire source continuously	Better fire resistance, copper being a metal	Being metallic, offers better fire resistance
Installation	Quick, easy and cost-effective - through cold welding. No electricity or heat source required.	Highly skilled manpower required to install. Also needs electricity/ heat source	Complicated and very slow. Requires more man hours.
Leakage	Long life leak-free piping systems (Installation to be done as per manual)	If carried out by highly trained manpower, gives a leak-free performance	Highly susceptible to leakage from the time of installation
Thermal expansion	More thermal expansion than metal yet the stress induced is relatively lower	Thermal expansion is lower yet the stress induced is greater	Lower thermal expansion but the stress induced is greater
Range of fittings	Preferred choice of architects, consultants, builders and end users as the wide range ensures that layout is compact as well as easy	Involves frequent cutting or welding to achieve the desired layout as the range of fittings is very limited	Limited range of fittings

# THE 'PLUS' IN PRINCE FLOWGUARD PLUS

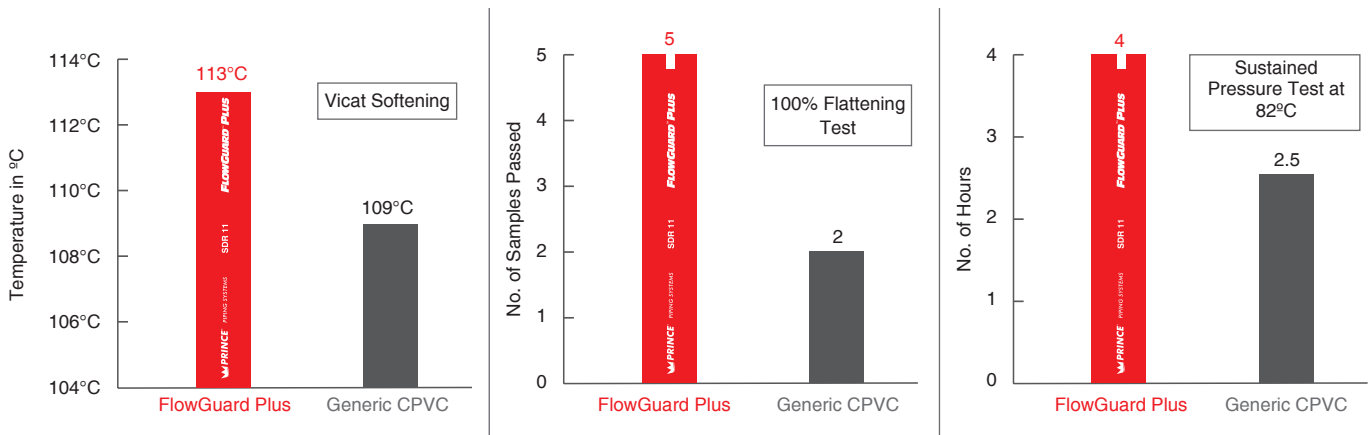

FACTOR	PRINCE FLOWGUARD PLUS CPVC	GENERIC CPVC
Compound credibility	Inventors of CPVC compound.	New and unproven.
Assembly	Complete system of Prince FlowGuard Plus (Pipes, Fittings & Solvent Cements).	Different sources for making the system complete.
Market reach	Highest number of projects in India.	Piggybacking the success of FlowGuard to capture market.
Material strength	Withstands test duration of 4 hours (Sustained Pressure Test as per ASTM) assuring long life.	Fails before the test duration of 4 Hours, meaning higher probability of failure.
Durability	No cracks or damage observed, ensuring better quality of compound.	Gets damaged easily, questionable quality of compound.
Pressure rating	Higher HDB compounds result in 25% higher pressure rating at elevated temperatures.	Normal compound means no additional pressure rating.
Quality consistency	Finished products manufactured exclusively by our global network of select manufacturing partners to ensure product quality and consistency.	Multiple manufacturers. Raw material from different sources.
Popularity	All top ten national builders specify our technology by name. Leader in testing and code acceptance efforts.	No national specification. Limited code support.
Standard	All compounds and finished goods produced to one standard. Quality Assurance Program helps ensure that only the highest quality CPVC finished goods are delivered to the marketplace.	Multiple formulation processes from raw material to the finished product.
Safety	Product manufactured with a safety factor of 2.0. Designed & manufactured for a service life of 50 years (Time Tested).	No history of the product & no mention of safety factor by manufacturers.

SDR	PRINCE FLOWGUARD PLUS CPVC	GENERIC CPVC
	ASTM Cell Classification 23448	ASTM Cell Classification 23447
	Pressure Ratings	Pressure Ratings
11	8.79 kg/cm <sup>2</sup> @ 82°C	7.03 kg/cm <sup>2</sup> @ 82°C
	28.1 kg/cm <sup>2</sup> @ 23°C	28.1 kg/cm <sup>2</sup> @ 23°C
13.5	7.03 kg/cm <sup>2</sup> @ 82°C	5.62 kg/cm <sup>2</sup> @ 82°C
	22.5 kg/cm <sup>2</sup> @ 23°C	22.5 kg/cm <sup>2</sup> @ 23°C

# BASIC PROPERTIES OF PRINCE FLOWGUARD PLUS CPVC

Sl.No.	Property	Test	Condition	English Units	S.I. Units
--------	----------	------	-----------	---------------	------------

## GENERAL

1	Specific Gravity	ASTM D792	73°F/23°C	1.50 - 1.53	1.50 - 1.53
2	Specific Volume	-	73°F/23°C	0.645 ft³/lb	0.645 cm³/g
3	Water Absorption	ASTM D570	73°F/23°C 212°F/100°C	0.03%, 0.55%	0.03%, 0.55%
4	Rockwell Hardness	ASTM D785	73°F/23°C	119	-
5	Cell Classification	ASTM D1784	-	23448	-

## MECHANICAL

1	Izod Impact	ASTM D256	73°F/23°C	1.5 ft lbs/in.	80 J/m
2	Tensile Strength	ASTM D638	73°F/23°C	8000 psi	55 N/mm²
3	Tensile Modulus	ASTM D638	73°F/23°C	360,000 psi	2500 N/mm²
4	Flexural Strength	ASTM D790	73°F/23°C	15,100 psi	104 N/mm²
5	Flexural Modulus	ASTM D790	73°F/23°C	415,000 psi	2860 N/mm²
6	Compressive Strength	ASTM D695	73°F/23°C	10,100 psi	70 N/mm²
7	Compressive Modulus	ASTM D695	73°F/23°C	196,000 psi	1350 N/mm²

## THERMAL PROPERTIES

1	Coefficient of Thermal Expansion	ASTM D696	-	3.4x10 <sup>-5</sup> in/in/°F	6.3 x 10 <sup>-5</sup> Watt/m/°K
2	Thermal Conductivity	ASTM C177	-	0.95 BTU in/hr/°F	0.14 W.m/°K
3	Heat Distortion Temperature	ASTM D648	-	217°F	103 °C
4	Heat Capacity	DSC	73°F/23°C 212°F/100°C	0.21 BTU/lb°F 0.26 BTU/lb°F	0.90 J/g°K, 1.10 J/g°K

## FLAMMABILITY

1	Flammability Rating	UL94   Euroclass (EN 13501-1) B-s1 d0	-	0.062 in/0.157cm	V-0, 5VB, 5VA
2	Flame Spread	ASTM E84	-	15	-
3	Smoke Developed	ASTM E84	-	70-125	-
4	Limiting Oxygen Index	ASTM D2863	-	60%	-

## ELECTRICAL

1	Dielectric Strength	ASTM D147	-	1250 V/mil	492,000 V/cm
2	Dielectric Constant	ASTM D149	60 Hz, 30°F/-1°C	3.7	3.7
3	Power Factor	ASTM D150	1000 Hz	0.007%	0.007%
4	Volume Resistivity	ASTM D257	73°F/23°C	3.4x10 <sup>15</sup> ohm/cm	3.4x10 <sup>15</sup> ohm/cm



# STANDARDS FOR PIPES & FITTINGS

Prince FlowGuard Plus CPVC pipes and fittings are manufactured in sizes from 1/2" to 10".

Pipe			Fitting		
Class	Standard	Sizes Available	Class	Standard	Sizes Available
Class-1 / SDR 11 Pipe	IS 15778 : 2007	1/2" - 2"	SDR 11 Fittings	#ASTM D 2846 : 2011/ *IS 17546:2021	1/2" - 2"
Class-2 / SDR 13.5 Pipe	IS 15778 : 2007	1/2" - 2"	-	-	-
SCH 40 Pipe	#ASTM F 441 : 2013	2 1/2" - 10"	SCH 40 Fittings	#ASTM F 438 : 2009	2 1/2" - 6"
SCH 80 Pipe	#ASTM F 441 : 2013	2 1/2" - 10"	SCH 80 Fittings/ SDR-17 Fittings*	#ASTM F 439 : 2013/ IS17546:2021*	2 1/2" - 4"

\*IS 17546 :-2021 -Fittings introduced shortly.

# Referred for dimensions only

## FLOWGUARD PLUS CODE COMPLIANCE

Code	Organisation
BOCA National Plumbing Code	Officials and Code Administrational, Inc.
National Standard Plumbing Code	National Association of Plumbing-Heating-Cooling Contractors
Standard Plumbing Code	Southern Building Code Congress International, Inc
Uniform Plumbing Code	International Association of Plumbing and Mechanical Officials
CAB01 and 2 Family Dwelling Code	Council of American Building Officials

## WORKING PRESSURE RATING OF FITTINGS

AS PER IS 17546:2021

Size (mm)	Class	Working Pressure	
		At 27°C (Kg/cm <sup>2</sup> )	At 82°C (Kg/cm <sup>2</sup> )
15 to 50 (1/2" to 2")	SDR -11	28.14	6.93
65 to 150 (2 1/2" to 6")	SDR-17	17.64	4.28

# FEATURES AND BENEFITS



Lubrizon's NSF/ANSI 14 certified TEMPRITE® 88619 TAN 311 & TEMPRITE® 88096 TAN 311 CPVC compounds respectively



Consistent product quality



Suitable for use up to 93°C



Low thermal expansion



25% Higher pressure bearing capacity at higher temperatures



UV resistant



Freedom from toxicity, odours and tastes



Peace of mind assured



High tensile and impact strength

---

# APPLICATIONS



Indoor and outdoor installations of hot & cold water plumbing lines



Residential & commercial buildings



For concealed, downtake & terrace looping



Solar water heaters



Public utilities & swimming pools

# PIPES DIMENSIONS AND WORKING PRESSURE

Nominal Bore		Outside Diameter		SDR 11 ( IS 15778 )				SDR 13.5 ( IS 15778 )			
mm	inch	Min (mm)	Max (mm)	Wall Thickness		Working Pressure		Wall Thickness		Working Pressure	
				Min (mm)	Max (mm)	At 27°C (kg/cm <sup>2</sup> )	At 82°C (kg/cm <sup>2</sup> )	Min (mm)	Max (mm)	At 27°C (kg/cm <sup>2</sup> )	At 82°C (kg/cm <sup>2</sup> )
15	1/2	15.80	16.00	1.70 <sup>#</sup>	2.20 <sup>#</sup>	28.14	6.93	1.40 <sup>#</sup>	1.90 <sup>#</sup>	22.22	5.60
20	3/4	22.10	22.30	2.00	2.50	28.14	6.93	1.70	2.20	22.22	5.60
25	1	28.50	28.70	2.60	3.10	28.14	6.93	2.10	2.60	22.22	5.60
32	1 1/4	34.80	35.00	3.20	3.70	28.14	6.93	2.60	3.10	22.22	5.60
40	1 1/2	41.20	41.40	3.80	4.30	28.14	6.93	3.10	3.60	22.22	5.60
50	2	53.90	54.10	4.90	5.50	28.14	6.93	4.00	4.60	22.22	5.60

Nominal Bore		Outside Diameter	Schedule 40 ( ASTM F 441 )				Schedule 80 ( ASTM F 441 )			
mm	inch	(mm)	Wall Thickness		Working Pressure		Wall Thickness		Working Pressure	
			Min (mm)	Max (mm)	At 27°C (kg/cm <sup>2</sup> )	At 82°C (kg/cm <sup>2</sup> )	Min (mm)	Max (mm)	At 27°C (kg/cm <sup>2</sup> )	At 82°C (kg/cm <sup>2</sup> )
65	2 1/2	73.00 (+/- 0.18)	5.16	5.77	21.10	5.30	7.01	7.85	29.57	7.34
80	3	88.90 (+/- 0.20)	5.49	6.15	18.25	4.58	7.62	8.53	26.00	6.32
100	4	114.30 (+/- 0.23)	6.02	6.73	15.49	3.87	8.56	9.58	22.53	5.60
150	6	168.30 (+/- 0.28)	7.11	7.97	12.64	3.16	10.97	12.29	19.68	4.89
200	8	219.10 (+/- 0.38)	8.18	9.17	11.21	2.85	12.70	14.22	17.54	4.18
250	10	273.10 (+/- 0.38)	9.27	10.39	9.89	2.44	15.06	16.86	16.21	3.87

FlowGuard Plus CPVC has 25% higher pressure bearing capacity at higher temperatures

- Note:
- Dimensions with '#' are not a function of SDR
  - Fittings are suitable for corresponding pipe pressure ratings

## PIPE DERATING FACTOR

Prince FlowGuard Plus CPVC Plumbing Systems' ability to perform even at increased temperatures gives them a better derating factor. Another reason why FlowGuard Plus CPVC Plumbing Systems come with a promise of 50 years of life.

Working Temperature		Pipe Derating Factor	
°F	°C	FlowGuard Plus	Generic CPVC
73 - 80	23 - 27	1.00	1.00
90	32	0.91	0.91
100	38	0.83	0.82
120	49	0.70	0.65
140	60	0.57	0.50
160	71	0.44	0.40
180	82	0.31	0.25

The pressure de-rating factor is same for all CPVC pipe sizes

# PRINCE FLOWGUARD PLUS FITTINGS PERFECT FIT ADVANTAGES

## Female Threaded Adaptor (Heavy Brass Insert)

- Hex type heavy design inserts, which can tolerate heavy torque. Special quality brass material ensures long service life of threads.
- O-ring made of EPDM used with brass inserts for avoiding leakage.
- Knurling provided for inserts for firm gripping with CPVC material during moulding process, which ensures high torque.

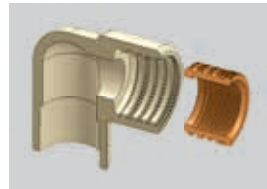
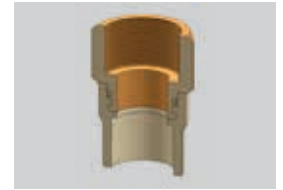

## Female Threaded Elbow (Brass Insert)

- Hex type heavy design inserts, which can tolerate heavy torque. Special quality brass material ensures long service life of threads.
- O-ring made of EPDM used with brass inserts for avoiding leakage.
- Knurling provided for inserts for firm gripping with CPVC material during moulding process, which ensures high torque.

## Tee - 65mm, 80mm, 100mm (2 1/2", 3" & 4")

- Ribs provided for plumbing alignment

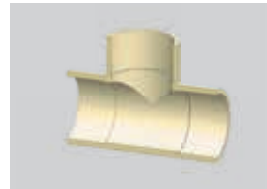

## Elbow 65mm, 80mm, 100mm (2 1/2", 3" & 4")

- Ribs provided for plumbing alignment



## Female Threaded Adaptor

- Ribs provided near hex portion for a firm wrench grip to provide strength to female threaded adaptor



# THREADED FITTINGS

Male and female threaded fittings are available as transition fittings with purely & solely molded from CPVC material as well as with CPVC Brass insert moulding options.

- Don't use CPVC threaded female adaptors while using as a transition fitting with metallic threaded fitting or pipe. It is recommended to use CPVC male threads be screwed into metallic female threads rather than metallic male threads into CPVC female threads.
- CPVC threaded male adaptors are recommended for cold water applications only. Brass insert moulded threaded transition fittings are recommended for all hot water applications.
- Use of Teflon tape is recommended for all threaded connections. While applying Teflon tape on threads, start with two wraps at the end of the fitting and wrap further threads overlapping half the width of the tape in the direction of the threads on each wind wrap.
- Before applying any type of thread sealant, check for its chemical compatibility with CPVC & brass material. Do not use sealant compound containing ammonia or chlorine on brass insert threaded fittings.
- Initially brass insert threaded fittings and CPVC fittings have to be tightened by hand and then with the help of a wrench, just half turn torque has to be applied for final thread joint tightening.
- Pneumatic tools are not recommended for tightening.
- Do not clamp brass threads of fitting in bench vice.



# FITTINGS DIMENSIONS



## COUPLER

### COUPLER (SDR 11)

Size (mm)	Size (inch)	ØD	C	Z	H
15	1/2	15.90	12.70	2.60	28.00
20	3/4	22.20	17.80	2.60	38.20
25	1	28.60	22.90	2.60	48.40
32	1 1/4	34.90	27.95	2.60	58.50
40	1 1/2	41.30	33.05	2.60	68.70
50	2	54.00	43.20	2.60	89.00

Refer Figure - 1

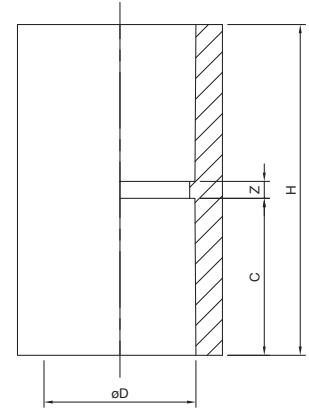

Figure - 1

### COUPLER (SCH 80 / SDR 17)

Size (mm)	Size (inch)	ØD	C	Z	H
65	2 1/2	73.00	44.45	4.80	93.70
80	3	88.90	47.65	4.80	100.10
100	4	114.30	57.15	4.80	119.10

Refer Figure - 1

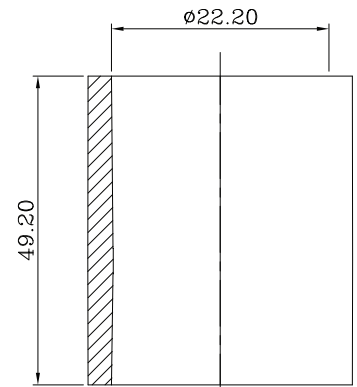

Figure - 2

### COUPLER (SCH 40)

Size (mm)	Size (inch)	ØD	C	Z	H
65	2 1/2	73.00	45.00	5.00	95.00
80	3	88.90	48.00	5.80	101.80
100	4	114.30	55.00	7.00	117.00
150	6	168.30	77.00	6.20	160.20

Refer Figure - 1

### REPAIR COUPLER (SCH 40)

Size (mm)	Size (inch)
20	3/4

Refer Figure - 2



## ELBOW

### ELBOW (SDR 11)

Size (mm)	Size (inch)	ØD	C	Z	H & L
15	1/2	15.90	12.70	9.70	32.60
20	3/4	22.20	17.80	12.90	44.75
25	1	28.60	22.90	16.10	56.45
32	1 1/4	34.90	27.95	19.25	68.40
40	1 1/2	41.30	33.05	22.45	80.55
50	2	54.00	43.20	28.85	104.55

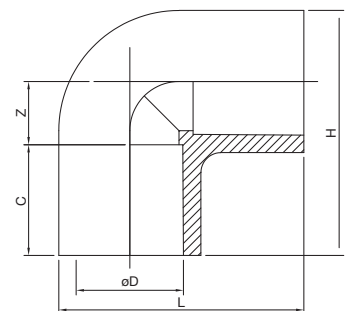



## ELBOW

### ELBOW (SCH 80 / SDR 17)

Size (mm)	Size (inch)	ØD	C	Z	H & L
65	2 1/2	73.00	44.45	38.10	127.25
80	3	88.90	47.65	46.05	146.95
100	4	114.30	57.15	58.75	182.85

Refer Figure - 1

### ELBOW (SCH 40)

Size (mm)	Size (inch)	ØD	C	Z	H & L
65	2 1/2	73.00	45.00	41.50	128.35
80	3	88.90	48.00	49.50	147.65
100	4	114.30	55.00	58.75	184.40
150	6	168.30	77.00	89.50	258.15

Refer Figure - 1



### REDUCING ELBOW (SDR 11)

Size (mm)	Size (inch)	ØD1	ØD2	C1	C2	Z1	Z2	H	L
20 X 15	3/4 X 1/2	22.20	15.90	17.80	12.70	12.90	13.30	41.15	39.70
25 X 20	1 X 3/4	28.60	22.20	22.90	17.80	17.10	16.20	55.00	51.60

Refer Figure - 2

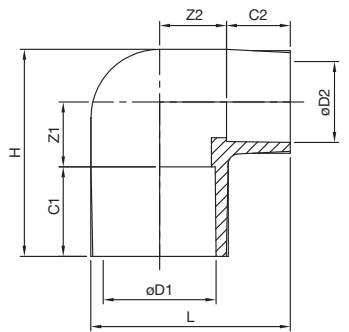

Figure - 2



## ELBOW 45°

(SDR 11)

Size (mm)	Size (inch)	ØD	C	Z	H	L
15	1/2	15.90	12.70	4.65	36.85	29.70
20	3/4	22.20	17.80	6.00	50.55	40.75
25	1	28.60	22.90	7.30	63.90	51.10
32	1 1/4	34.90	27.95	8.65	77.55	62.35
40	1 1/2	41.30	33.05	9.95	91.10	73.15
50	2	54.00	43.20	12.60	118.25	94.95

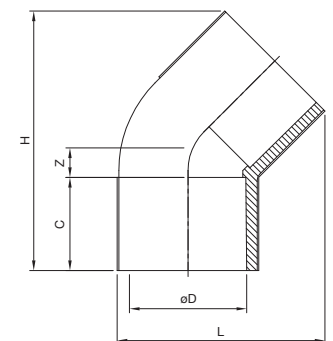



## EQUAL TEE

### TEE (SDR 11)

Size (mm)	Size (inch)	ØD	C	Z	H	L
15	1/2	15.90	12.70	9.70	44.80	32.60
20	3/4	22.20	17.80	12.90	61.40	44.75
25	1	28.60	22.90	16.10	78.00	56.45
32	1 1/4	34.90	27.95	19.25	94.40	68.40
40	1 1/2	41.30	33.05	22.45	111.00	80.55
50	2	54.00	43.20	28.85	144.10	104.55

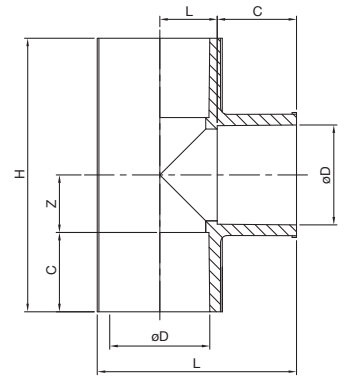

### TEE (SCH 80 / SDR 17)

Size (mm)	Size (inch)	ØD	C	Z	H	L
65	2 1/2	73.00	44.45	38.10	165.10	127.25
80	3	88.90	47.65	46.05	187.40	146.95
100	4	114.30	57.15	58.75	231.80	182.85

### TEE (SCH 40)

Size (mm)	Size (inch)	ØD	C	Z	H	L
65	2 1/2	73.00	45.00	44.00	178.00	130.85
80	3	88.90	48.00	51.50	199.00	149.65
100	4	114.30	55.00	67.00	244.00	185.40
150	6	168.30	77.00	89.50	333.00	258.15



## REDUCING TEE

### REDUCING TEE (SDR 11)

Size (mm)	Size (inch)	ØD1	ØD2	C1	C2	Z1	Z2	H	L
20 X 15	3/4 X 1/2	22.20	15.90	17.80	12.70	9.70	12.90	55.00	39.25
25 X 15	1 X 1/2	28.60	15.90	22.90	12.70	12.90	16.10	71.60	46.25
25 X 20	1 X 3/4	28.60	22.20	22.90	17.80	12.90	16.10	71.60	51.35
32 X 15	1 1/4 X 1/2	34.90	15.90	27.95	12.70	16.10	19.25	88.10	53.15
32 X 20	1 1/4 X 3/4	34.90	22.20	27.95	17.80	16.10	19.25	88.10	58.25
32 X 25	1 1/4 X 1	34.90	28.60	27.95	22.90	16.10	19.25	88.10	63.35
40 X 15	1 1/2 X 1/2	41.30	15.90	33.05	12.70	19.25	22.45	104.60	60.20
40 X 20	1 1/2 X 3/4	41.30	22.20	33.05	17.80	19.25	22.45	104.60	65.30

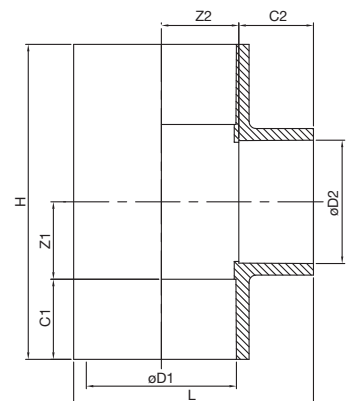



## REDUCING TEE

### REDUCING TEE (SDR 11)

Size (mm)	Size (inch)	ØD1	ØD2	C1	C2	Z1	Z2	H	L
40 X 25	1 1/2 X 1	41.30	28.60	33.05	22.90	19.25	22.45	104.60	70.40
40 X 32	1 1/2 X 1 1/4	41.30	34.90	33.05	27.95	19.25	22.45	104.60	75.45
50 X 15	2 X 1/2	54.00	15.90	43.20	12.70	22.45	28.85	131.30	74.05
50 X 20	2 X 3/4	54.00	22.20	43.20	17.80	22.45	28.85	131.30	79.15
50 X 25	2 X 1	54.00	28.60	43.20	22.90	22.45	28.85	131.30	84.25
50 X 32	2 X 1 1/4	54.00	34.90	43.20	27.95	22.45	28.85	131.30	89.30
50 X 40	2 X 1 1/2	54.00	41.30	43.20	33.05	22.45	28.85	131.30	94.40

### REDUCING TEE (SCH 80 / SDR 17)

Size (mm)	Size (inch)	ØD1	ØD2	C1	C2	Z1	Z2	H	L
65 X 50 <sup>#</sup>	2 1/2 X 2	73.00	54.00	44.45	43.20	32.00	38.10	152.90	125.00
80 X 50 <sup>#</sup>	3 X 2	88.90	54.00	47.65	43.20	33.00	46.05	161.30	141.45
80 X 65	3 X 2 1/2	88.90	73.00	47.65	44.45	46.05	46.05	187.40	142.70
100 X 50 <sup>#</sup>	4 X 2	114.30	54.00	57.15	43.20	35.00	58.75	184.30	168.15
100 X 65	4 X 2 1/2	114.30	73.00	57.15	44.45	58.75	58.75	231.80	169.40
100 X 80	4 X 3	114.30	88.90	57.15	47.65	58.75	58.75	231.80	172.60

<sup>#</sup>Not in Schedule 80

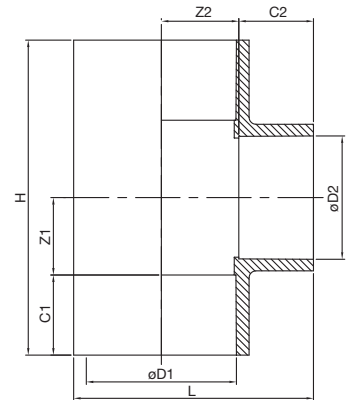

## FOUR WAY TEE

(SDR 11)

Size (mm)	Size (inch)	ØD	C	Z	H & L
15	1/2	15.90	12.70	9.70	44.80
20	3/4	22.20	17.80	12.90	61.40

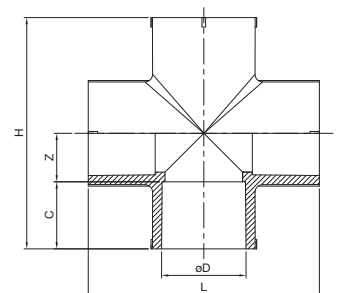





## END CAP

### END CAP (SDR 11)

Size (mm)	Size (inch)	ØD	C	H
15	1/2	15.90	12.70	18.00
20	3/4	22.20	17.80	25.00
25	1	28.60	22.90	30.00
32	1 1/4	34.90	27.95	37.00
40	1 1/2	41.30	33.05	42.50
50	2	54.00	43.20	55.20

Refer Figure - 1

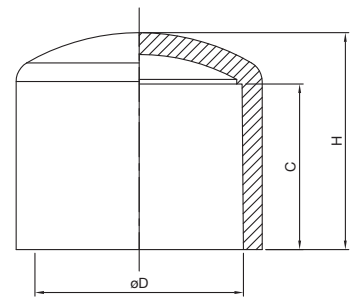

Figure - 1

### END CAP (COLLAR TYPE) (SCH 80 / SDR 17)

Size (mm)	Size (inch)	ØD	ØD1	C	H
65	2 1/2	73.00	91.60	44.45	55.00
80	3	88.90	108.10	47.65	60.00
100	4	114.30	136.65	57.15	71.00

Refer Figure - 2

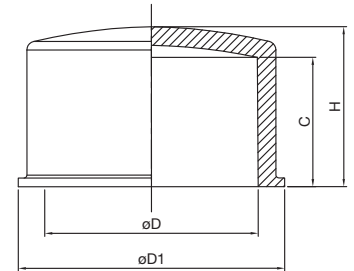

Figure - 2

### END CAP (SCH 40)

Size (mm)	Size (inch)	ØD	C	H
150	6	168.30	77.00	101.00

Refer Figure - 3

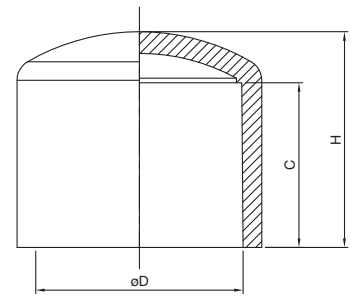

Figure - 3



## UNION

### (SDR 11)

Size (mm)	Size (inch)	ØD	C	ØH	L
15	1/2	15.90	12.70	32.60	35.50
20	3/4	22.20	17.80	44.80	46.80
25	1	28.60	22.90	53.90	58.00
32	1 1/4	34.90	27.95	64.50	70.55
40	1 1/2	41.30	33.05	78.50	80.45
50	2	54.00	43.20	91.50	102.00

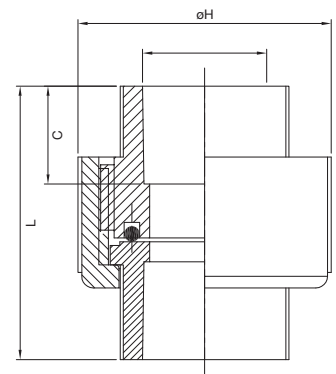



## CROSS OVER

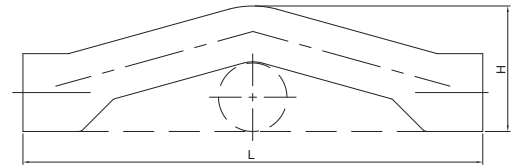

(SDR 11) (MOULDED)

Size (mm)	Size (inch)	H	L
20	3/4	52.40	192.00
25	1	64.00	252.80



## CROSS OVER

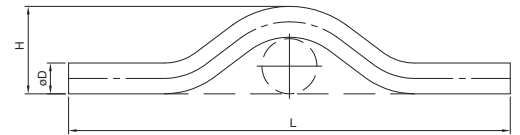

(SDR 11) (FABRICATED)

Size (mm)	Size (inch)	ØD	H	L
15	1/2	15.90	45.75	229.00
20	3/4	22.20	48.80	251.00
25	1	28.60	58.00	339.00



## FABRICATED BEND

(SDR 11)

Size (mm)	Size (inch)	ØA	C	H
15	1/2	15.90	73.00	124.00
20	3/4	22.20	65.00	130.00
25	1	28.60	60.00	150.00
32	1 1/4	34.90	70.00	161.00
40	1 1/2	41.30	65.00	171.00
50	2	54.00	55.00	193.00

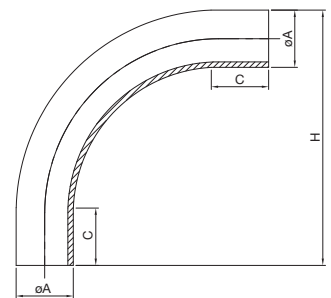



## MALE THREADED ADAPTOR

### MALE THREADED ADAPTOR (SDR 11)

Size (mm)	Size (inch)	ØD	C	Threads	L <sub>T</sub>	H	A/C
15	1/2	15.90	12.70	1 1/2" (14-TPI)	17.00	32.30	24.50
20	3/4	22.20	17.80	3/4" (14-TPI)	16.50	36.90	30.95
25	1	28.60	22.90	1" (11-TPI)	21.10	46.80	39.30
32	1 1/4	34.90	27.95	1 1/4" (11-TPI)	23.15	54.50	48.50
40	1 1/2	41.30	33.05	1 1/2" (11-TPI)	24.60	61.75	56.95
50	2	54.00	43.20	2" (11-TPI)	26.00	74.40	74.15

Refer Figure - 1

### MALE THREADED ADAPTOR (SCH 80 / SDR 17)

Size (mm)	Size (inch)	ØD	C	Threads	L <sub>T</sub>	H	A/C
65	2 1/2	73.00	44.45	2 1/2" (14-TPI)	29.00	79.50	100.30
80	3	88.90	47.65	3" (14-TPI)	32.00	86.00	120.10
100	4	114.30	57.15	4" (11-TPI)	38.00	102.00	151.65

Refer Figure - 1



### REDUCING MALE THREADED ADAPTOR (SDR 11)

Size (mm)	Size (inch)	ØD	C	Threads	L <sub>T</sub>	H	A/C
20 X 15	3/4 X 1/2	22.20	17.80	1/2" (14-TPI)	17.00	38.00	31.20
25 X 20	1 X 3/4	28.60	22.90	3/4" (14-TPI)	16.50	42.60	39.00

Refer Figure - 2

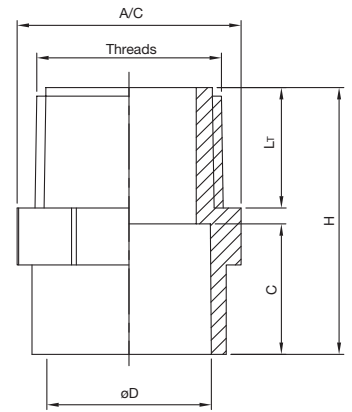

Figure - 1

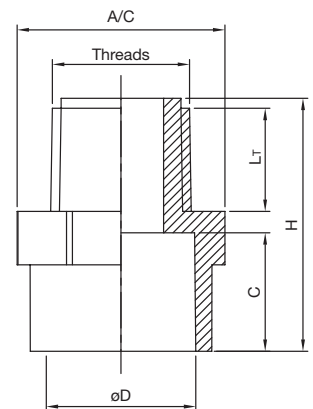

Figure - 2



## FEMALE THREADED ADAPTOR

### FEMALE THREADED ADAPTOR (SDR 11)

Size (mm)	Size (inch)	ØD	C	Threads	L <sub>T</sub>	H	A/C
15	1/2	15.90	12.70	1/2" (14-TPI)	15.30	32.50	30.60
20	3/4	22.20	17.80	3/4" (14-TPI)	15.75	38.05	37.20
25	1	28.60	22.90	1" (11-TPI)	18.50	45.90	46.60
32	1 1/4	34.90	27.95	1 1/4" (11-TPI)	20.80	53.75	57.15
40	1 1/2	41.30	33.05	1 1/2" (11-TPI)	22.10	60.15	64.20
50	2	54.00	43.20	2" (11-TPI)	23.40	71.60	80.25

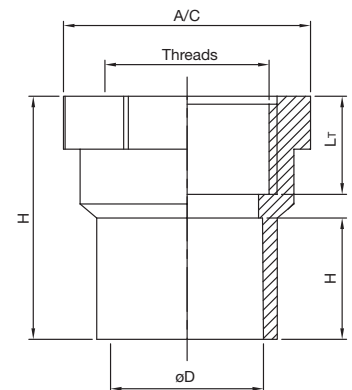



## FEMALE THREADED ADAPTOR

### FEMALE THREADED ADAPTOR (SCH 80 / SDR 17)

Size (mm)	Size (inch)	ØD	C	Threads	L <sub>T</sub>	H	A/C
65	2 1/2	73.00	44.45	2 1/2" (11-TPI)	31.00	80.00	99.70
80	3	88.90	47.65	3" (11-TPI)	34.00	86.00	119.00
100	4	114.30	57.15	4" (11-TPI)	40.00	102.00	149.65

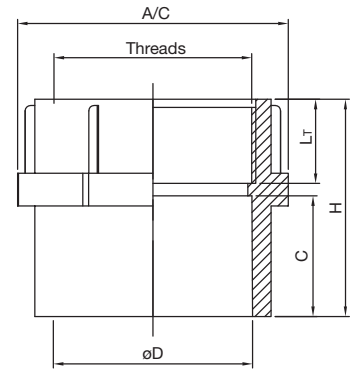

Figure - 1

Refer Figure - 1



### REDUCING FEMALE THREADED ADAPTOR (SDR 11)

Size (mm)	Size (inch)	ØD	C	Threads	L <sub>T</sub>	H	A/C
20 X 15	3/4 X 1/2	22.20	17.80	1/2" (14-TPI)	17.00	36.60	33.20

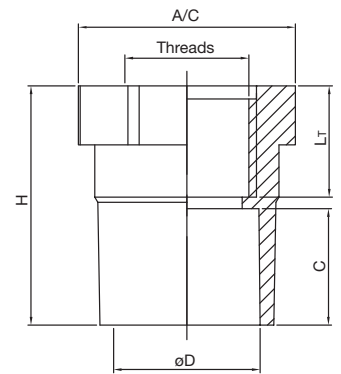

Figure - 2

Refer Figure - 2



## REDUCER

### REDUCER (SDR 11)

Size (mm)	Size (inch)	ØD1	ØD2	C1	C2	Z	H
20 X 15	3/4 X 1/2	22.20	15.90	17.80	12.70	2.60	33.10
25 X 15	1 X 1/2	28.60	15.90	22.90	12.70	2.60	38.20
25 X 20	1 X 3/4	28.60	22.20	22.90	17.80	2.60	43.30
32 X 15	1 1/4 X 1/2	34.90	15.90	27.95	12.70	2.60	43.25
32 X 20	1 1/4 X 3/4	34.90	22.20	27.95	17.80	2.60	48.35
32 X 25	1 1/4 X 1	34.90	28.60	27.95	22.90	2.60	53.45
40 X 15	1 1/2 X 1/2	41.30	15.90	33.05	12.70	2.60	48.35
40 X 20	1 1/2 X 3/4	41.30	22.20	33.05	17.80	2.60	53.45
40 X 25	1 1/2 X 1	41.30	28.60	33.05	22.90	2.60	58.55
40 X 32	1 1/2 X 1 1/4	41.30	34.90	33.05	27.95	2.60	63.60
50 X 15	2 X 1/2	54.00	15.90	43.20	12.70	2.60	58.50
50 X 20	2 X 3/4	54.00	22.20	43.20	17.80	2.60	63.60
50 X 25	2 X 1	54.00	28.60	43.20	22.90	2.60	68.70
50 X 32	2 X 1 1/4	54.00	34.90	43.20	27.95	2.60	73.75
50 X 40	2 X 1 1/2	54.00	41.30	43.20	33.05	2.60	78.85

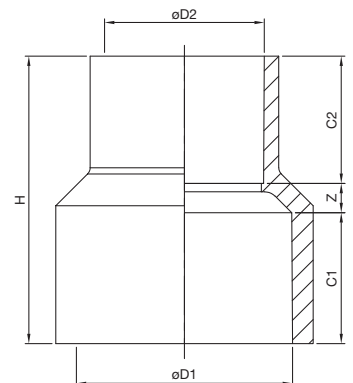



## REDUCER

### REDUCER (SCH 80 / SDR 17)

Size (mm)	Size (inch)	ØD1	ØD2	C1	C2	Z	H
65 X 50*	2 1/2 X 2	73.00	54.00	44.45	43.20	9.95	97.60
80 X 40	3 X 1 1/2	88.90	41.30	47.65	33.05	14.75	95.80
80 X 50*	3 X 2	88.90	54.00	47.65	43.20	15.15	106.00
80 X 65	3 X 2 1/2	88.90	73.00	47.65	44.45	13.90	106.00
100 X 50*	4 X 2	114.30	54.00	57.15	43.20	35.65	136.00
100 X 65	4 X 2 1/2	114.30	73.00	57.15	44.45	26.40	128.00
100 X 80	4 X 3	114.30	88.90	57.15	47.65	18.70	123.50

\*Not in Schedule 80

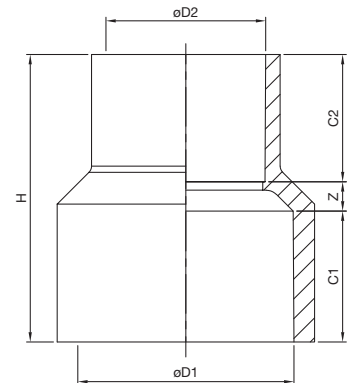

## REDUCING BUSH

### REDUCING BUSH (SDR 11)

Size (mm)	Size (inch)	ØD1	ØD2	ØD3	C1	C2	H
20 X 15	3/4 X 1/2	22.20	15.90	26.55	17.80	12.70	21.00
25 X 15	1 X 1/2	28.60	15.90	34.05	22.90	12.70	26.10
25 X 20	1 X 3/4	28.60	22.20	34.05	22.90	17.80	26.10
32 X 15	1 1/4 X 1/2	34.90	15.90	41.60	27.95	12.70	31.15
32 X 20	1 1/4 X 3/4	34.90	22.20	41.60	27.95	17.80	31.15
32 X 25	1 1/4 X 1	34.90	28.60	41.60	27.95	22.90	31.15
40 X 15	1 1/2 X 1/2	41.30	15.90	49.30	33.05	12.70	36.25
40 X 20	1 1/2 X 3/4	41.30	22.20	49.30	33.05	17.80	36.25
40 X 25	1 1/2 X 1	41.30	28.60	49.30	33.05	22.90	36.25
40 X 32	1 1/2 X 1 1/4	41.30	34.90	49.30	33.05	27.95	36.25
50 X 15	2 X 1/2	54.00	15.90	64.20	43.20	12.70	46.40
50 X 20	2 X 3/4	54.00	22.20	64.20	43.20	17.80	46.40
50 X 25	2 X 1	54.00	28.60	64.20	43.20	22.90	46.40
50 X 32	2 X 1 1/4	54.00	34.90	64.20	43.20	27.95	46.40
50 X 40	2 X 1 1/2	54.00	41.30	64.20	43.20	33.05	46.40

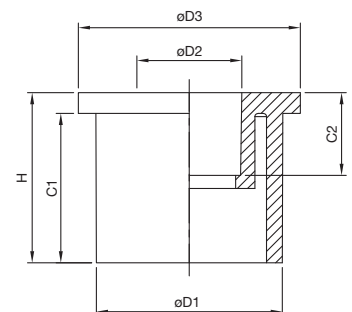



## REDUCING BUSH

### REDUCING BUSH (SCH 80 / SDR 17)

Size (mm)	Size (inch)	ØD1	ØD2	C1	C2	H	A/C
65 X 40	2 1/2 X 1 1/2	73.00	41.30	44.45	33.05	51.45	85.70
65 X 50	2 1/2 X 2	73.00	54.00	44.45	43.20	51.45	85.70
80 X 50	3 X 2	88.80	54.00	47.65	43.20	55.65	106.00
80 X 65	3 X 2 1/2	88.80	73.00	47.65	44.45	55.65	106.00
100 X 50	4 X 2	114.00	54.00	57.15	43.20	65.15	133.40
100 X 65	4 X 2 1/2	114.00	73.00	57.15	44.45	65.15	133.40
100 X 80	4 X 3	114.00	88.90	57.15	47.65	65.15	133.40

Refer Figure - 1

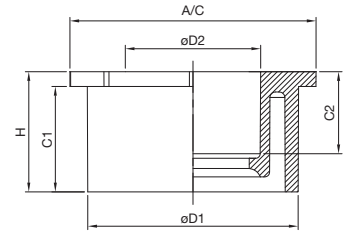
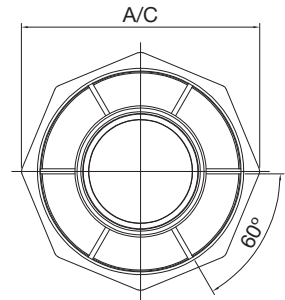

Figure - 1



### REDUCING BUSH (SCH 40)

Size (mm)	Size (inch)	ØD1	ØD2	C	H	A/C
150 X 80	6 X 3	168.30	77.00	89.50	333.00	258.15
150 X 100	6 X 4	168.30	114.30	51.00	85.00	183.72

Refer Figure - 2

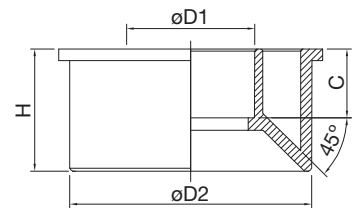

Figure - 2



## TRANSITION BUSH

### (SDR 11)

Size (mm)	Size (inch)	ØD1	ØD2	ØD3	C1	C2	H
15 X 15	1/2 ITS X 1/2 CTS	21.34	15.90	26.50	17.50	12.70	19.50
20 X 20	3/4 ITS X 3/4 CTS	26.67	22.20	32.50	18.30	17.80	21.30
25 X 25	1 ITS X 1 CTS	33.40	28.60	40.65	28.60	22.90	34.60
32 X 32	1 1/4 ITS X 1 1/4 CTS	42.16	34.90	48.00	31.75	27.95	35.00
40 X 40	1 1/2 ITS X 1 1/2 CTS	48.26	41.30	54.00	34.95	33.05	38.20
50 X 50	2 ITS X 2 CTS	60.32	54.00	68.00	38.10	43.20	45.60

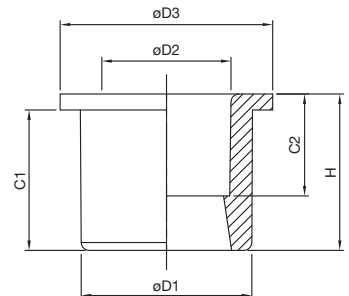





## TANK CONNECTOR

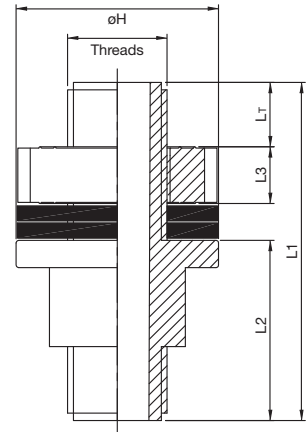

Size (mm)	Size (inch)	ØH	Threads	L <sub>T</sub>	L <sub>1</sub>	L <sub>2</sub>	L <sub>3</sub>
15	1/2	41.00	1/2" (14-TPI)	14.50	68.50	36.50	11.50
20	3/4	45.50	3/4" (14-TPI)	18.50	75.50	39.50	11.50
25	1	56.00	1" (11-TPI)	22.50	86.50	45.50	12.50
32	1 1/4	65.00	1 1/4" (11-TPI)	23.50	93.00	49.00	14.50
40	1 1/2	71.00	1 1/2" (11-TPI)	28.50	102.00	53.00	14.50
50	2	83.00	2" (11-TPI)	29.50	103.50	53.50	14.50



## TANK CONNECTOR PLAIN (SOCKET TYPE - MOULDED)

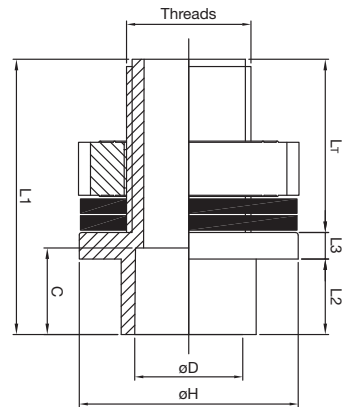

Size (mm)	Size (inch)	ØD	C	ØH	Threads	L <sub>T</sub>	L <sub>1</sub>	L <sub>2</sub>	L <sub>3</sub>
15	1/2	15.90	12.70	41.00	1/2" (14-TPI)	32.00	47.70	10.20	5.50
20	3/4	22.20	18.00	45.50	3/4" (14-TPI)	36.00	57.20	15.70	5.50
25	1	28.60	23.50	56.00	1" (11-TPI)	41.00	67.50	21.00	5.50
32	1 1/4	34.90	26.00	65.00	1 1/4" (11-TPI)	44.00	74.00	24.00	6.00
40	1 1/2	41.30	26.00	71.00	1 1/2" (11-TPI)	49.00	79.00	24.00	6.00
50	2	54.00	30.00	83.00	2" (11-TPI)	50.00	84.00	28.00	6.00



## FLANGE WITH SOCKET

### FLANGE WITH SOCKET (1 PC) (SDR 11)

Size (mm)	Size (inch)	ØD	ØD1	ØD2	C	H	P.C.D	No. of Hole	L X S	W
25	1	28.60	23.20	115.00	22.90	28.00	81.50	04	20.50 x 14.00	15.00
32	1 1/4	34.90	28.00	125.00	27.95	33.60	91.00	04	21.50 x 15.50	16.00
40	1 1/2	41.30	33.15	134.50	33.05	40.55	98.00	04	20.50 x 14.00	18.00
50	2	54.00	43.50	160.00	43.20	49.80	118.50	04	25.00 x 17.00	18.00

### FLANGE WITH SOCKET (1 PC) (SCH 80 / SDR 17)

Size (mm)	Size (inch)	ØD	ØD1	ØD2	C	H	P.C.D	No. of Hole	L X S	W
65	2 1/2	73.00	62.75	177.00	44.45	50.85	133.00	04	26.00 x 19.50	23.00
80	3	88.90	77.80	189.00	47.65	55.50	148.00	04	22.00 x 19.00	23.00
100	4	114.30	102.50	227.00	57.15	65.50	183.00	08	25.00 x 19.00	27.50

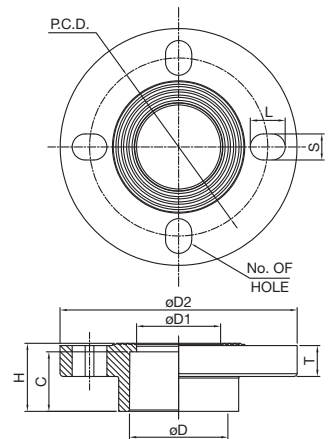



## BLIND FLANGE

(1 PC) (SDR 11)

Size (mm)	Size (inch)	ØD1	ØD2	H	P.C.D	No. of Hole	L X S	T
65	2 1/2	62.75	177.00	24.75	133.00	04	26.00 X 19.50	23.00
100	4	102.50	227.00	29.00	183.00	08	25.00 X 19.00	27.50

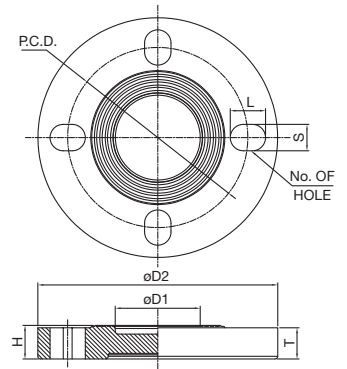

## METAL CLAMP\*

(POWDER COATED)

Size (mm)	Size (inch)	ØD	H	L
15	1/2	15.90	16.40	55.00
20	3/4	22.20	22.70	65.00
25	1	28.60	29.10	72.00
32	1 1/4	34.90	35.40	78.00
40	1 1/2	41.30	41.80	85.00
50	2	54.00	54.50	98.00

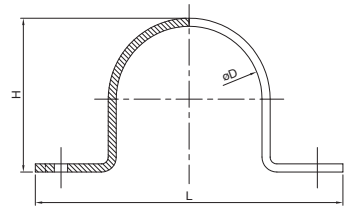

\*Non FlowGuard Plus Product



## EXTENDED END PLUG\*

Size (mm)	Size (inch)	ØD	Threads	L <sub>T</sub>	H
15	1/2	29.00	1/2" (14-TPI)	15.00	52.00
20	3/4	35.00	3/4" (14-TPI)	16.00	53.00

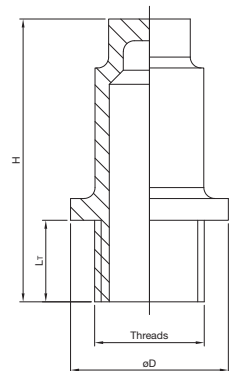

\*Non FlowGuard Plus Product



## CONCEALED VALVE\*

Size (mm)	Size (inch)
20	3/4
25	1

\*Non FlowGuard Plus Product



\*Non FlowGuard Plus Product

## BALL VALVE\* (UNION TYPE)

Size (mm)	Size (inch)
15	1/2
20	3/4
25	1
32	1 1/4
40	1 1/2
50	2
65	2 1/2
80	3
100	4

# BRASS INSERT FITTINGS DIMENSIONS



## MALE THREADED ADAPTOR

### MALE THREADED ADAPTOR (HEAVY) (SDR 11)

Size (mm)	Size (inch)	ØD	C	Threads	L <sub>T</sub>	H
15	1/2	15.90	14.00	1/2" (BSPT)	15.00	49.00
20	3/4	22.20	19.00	3/4" (BSPT)	15.00	56.00
25	1	28.60	24.00	1" (BSPT)	20.15	71.25
32	1 1/4	34.90	27.95	1 1/4" (BSPT)	21.20	80.75
40	1 1/2	41.30	33.05	1 1/2" (BSPT)	21.75	88.15
50	2	54.00	43.80	2" (BSPT)	22.60	102.25

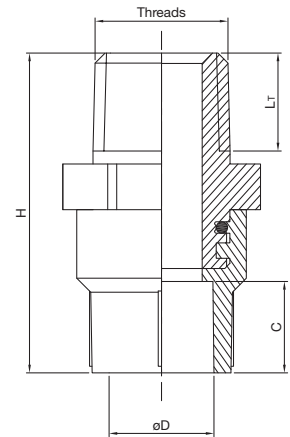

Figure - 1

Refer Figure - 1



### MALE THREADED ADAPTOR (HEAVY) (SDR 11)

Size (mm)	Size (inch)	ØD	C	Threads	L <sub>T</sub>	H	A/C
65	2 1/2	73.02	47.00	2 1/2" (11 -TPI)	25.00	111.30	97.80
80	3	89.90	50.50	3" (11-TPI)	28.00	114.40	116.00

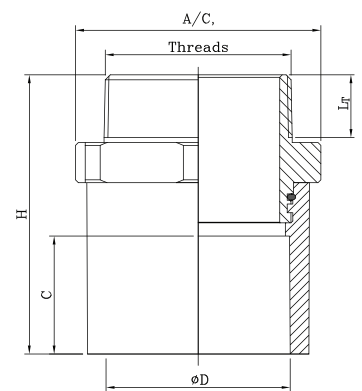

Figure - 2

Refer Figure - 2

### REDUCING MALE THREADED ADAPTOR (HEAVY) (SDR 11)

Size (mm)	Size (inch)	ØD	C	Threads	L <sub>T</sub>	H
20 X 15	3/4 X 1/2	22.20	19.00	1/2" (BSPT)	15.00	56.00

Refer Figure - 1



## MALE THREADED ADAPTOR

### MALE THREADED ADAPTOR (SDR 11)

Size (mm)	Size (inch)	ØD	C	Threads	L <sub>T</sub>	H
15	1/2	15.90	12.70	1/2" (14-TPI)	14.00	49.00
20	3/4	22.20	17.80	3/4" (14-TPI)	15.30	57.10
25	1	28.60	22.90	1" (11-TPI)	18.00	65.00
32	1 1/4	34.90	27.95	1 1/4" (11-TPI)	20.40	80.00
40	1 1/2	41.30	33.05	1 1/2" (11-TPI)	20.40	87.00
50	2	54.00	43.20	2" (11-TPI)	24.70	106.10

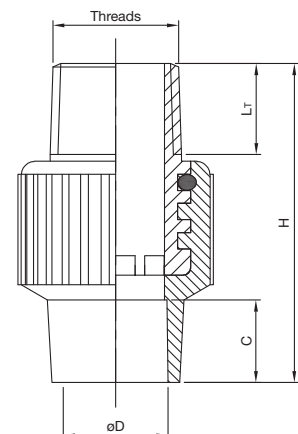



## MALE THREADED ADAPTOR

### REDUCING MALE THREADED ADAPTOR (SDR 11)

Size (mm)	Size (inch)	ØD	C	Threads	L <sub>T</sub>	H
20 X 15	3/4 X 1/2	22.20	17.80	1/2" (14-TPI)	14.00	53.30
25 X 15	1 X 1/2	28.60	22.90	1/2" (14-TPI)	14.00	58.00
25 X 20	1 X 3/4	28.60	22.90	3/4" (14-TPI)	15.30	60.25

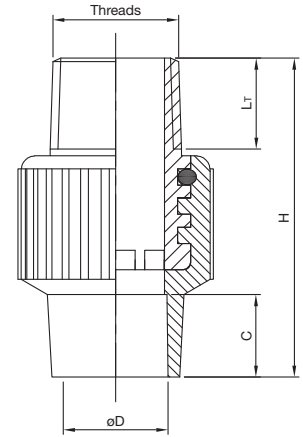

## FEMALE THREADED ADAPTOR

### FEMALE THREADED ADAPTOR (HEAVY) (SDR 11)

Size (mm)	Size (inch)	ØD	C	Threads	L <sub>T</sub>	H
15	1/2	15.90	14.00	1/2" (BSPT)	16.00	43.00
20	3/4	22.20	19.00	3/4" (BSPT)	16.75	50.00
25	1	28.60	24.00	1" (BSPT)	22.00	65.20
32	1 1/4	34.90	27.95	1 1/4" (BSPT)	26.60	78.40
40	1 1/2	41.30	33.05	1 1/2" (BSPT)	27.80	83.50
50	2	54.00	43.20	2" (BSPT)	25.40	93.50

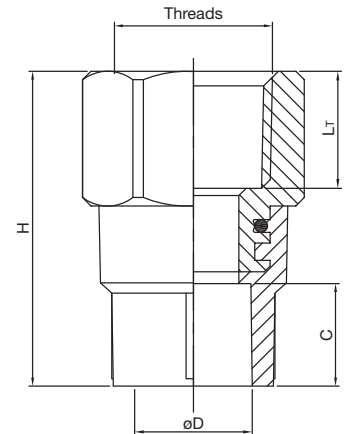

## FEMALE THREADED ADAPTOR

### FEMALE THREADED ADAPTOR (SDR 11)

Size (mm)	Size (inch)	ØD	C	Threads	L <sub>T</sub>	H
15	1/2	15.90	12.70	1/2" (14-TPI)	15.00	37.20
20	3/4	22.20	17.80	3/4" (14-TPI)	16.30	44.20
25	1	28.60	22.90	1" (11-TPI)	19.00	51.00
32	1 1/4	34.90	27.95	1 1/4" (11-TPI)	21.40	58.00
40	1 1/2	41.30	33.05	1 1/2" (11-TPI)	21.40	65.00
50	2	54.00	43.20	2" (11-TPI)	25.65	80.00

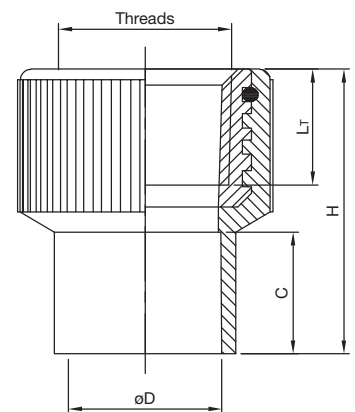



## FEMALE THREADED ADAPTOR

### FEMALE THREADED ADAPTOR (SDR11)

Size (mm)	Size (inch)	ØD	C	Threads	L <sub>T</sub>	H	A/C
65	2 1/2	73.02	47.00	2 1/2" (11-TPI)	28.00	87.40	109.50
80	3	89.90	50.50	3" (11-TPI)	28.00	90.20	126.70

Refer Figure - 1

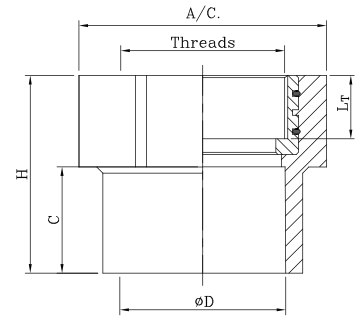

Figure - 1



### REDUCING FEMALE THREADED ADAPTOR (SDR 11)

Size (mm)	Size (inch)	ØD	C	Threads	L <sub>T</sub>	H
20 X 15	3/4 X 1/2	22.20	17.80	1/2" (14-TPI)	15.00	41.00
25 X 15	1 X 1/2	28.60	22.90	1/2" (14-TPI)	15.00	45.90
25 X 20	1 X 3/4	28.60	22.90	3/4" (14-TPI)	16.30	47.40

Refer Figure - 2

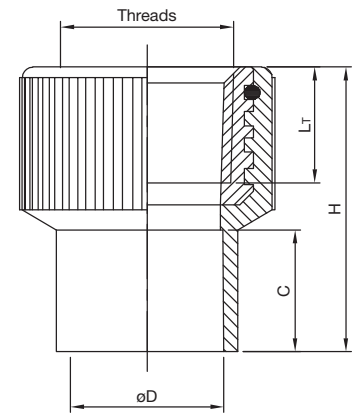

Figure - 2



## FEMALE THREADED ELBOW

### FEMALE THREADED ELBOW (SDR 11)

Size (mm)	Size (inch)	ØD	C	Z	Threads	L <sub>T</sub>	H	L
15	1/2	15.90	12.70	14.00	1/2" (14-TPI)	15.00	42.70	40.60
20	3/4	22.20	17.80	17.00	3/4" (14-TPI)	16.30	53.80	48.45
25	1	28.60	22.90	21.10	1" (11-TPI)	19.00	67.00	56.40
32	1 1/4	34.90	27.95	21.25	1 1/4" (11-TPI)	21.40	68.70	79.60

### REDUCING FEMALE THREADED ELBOW (SDR 11)

Size (mm)	Size (inch)	ØD	C	Z	Threads	L <sub>T</sub>	H	L
20 X 15	3/4 X 1/2	22.20	17.80	17.00	1/2" (14-TPI)	15.00	50.80	47.00
25 X 15	1 X 1/2	22.20	22.90	14.50	1/2" (14-TPI)	15.00	53.90	53.20
25 X 20	1 X 3/4	28.60	22.90	21.00	3/4" (14-TPI)	16.30	62.90	54.40

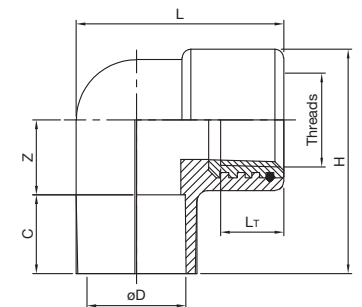



## EXTENDED FEMALE THREADED ELBOW

### EXTENDED FEMALE THREADED ELBOW (SDR 11)

Size (mm)	Size (inch)	ØD	C	Z	Threads	L <sub>T</sub>	H	L
15	1/2	15.90	12.70	14.00	1/2" (14-TPI)	18.00	42.70	70.60

### REDUCING EXTENDED FEMALE THREADED ELBOW (SDR 11)

Size (mm)	Size (inch)	ØD	C	Z	Threads	L <sub>T</sub>	H	L
20 X 15	3/4 X 1/2	22.20	17.80	17.00	1/2" (14-TPI)	18.00	50.80	73.00

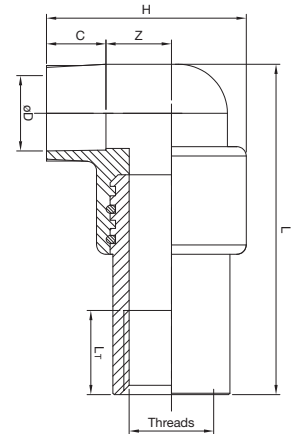

## FEMALE THREADED TEE

### FEMALE THREADED TEE (SDR 11)

Size (mm)	Size (inch)	ØD	C	Z	Threads	L <sub>T</sub>	H	L
15	1/2	15.90	12.70	9.70	1/2" (14-TPI)	15.00	44.80	41.00
20	3/4	22.20	17.80	12.90	3/4" (14-TPI)	16.30	61.40	48.50
25	1	28.60	22.90	16.10	1" (11-TPI)	19.00	78.00	55.90
32	1 1/4	34.90	27.95	19.25	1 1/4" (11-TPI)	21.40	94.40	68.30

### REDUCING FEMALE THREADED TEE (SDR 11)

Size (mm)	Size (inch)	ØD	C	Z	Threads	L <sub>T</sub>	H	L
20 X 15	3/4 X 1/2	22.20	17.80	12.90	1/2" (14-TPI)	15.00	61.40	49.45
25 X 15	1 X 1/2	28.60	22.90	16.10	1/2" (14-TPI)	15.00	78.00	52.95
25 X 20	1 X 3/4	28.60	22.90	16.10	3/4" (14-TPI)	16.30	78.00	56.15

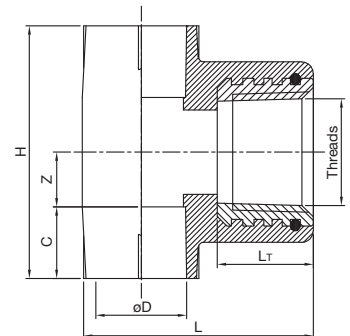

## WALL MIXER



### HOT DOWN & COLD DOWN

20mm (3/4") X 15mm (1/2")

Size (mm)	Size (inch)
150	6

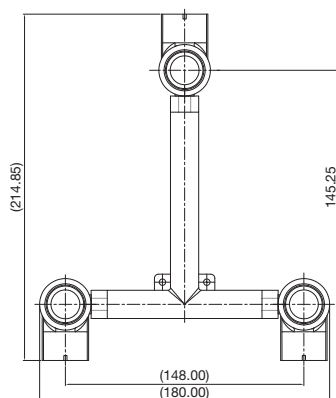

### HOT UP & COLD UP

20mm (3/4") X 15mm (1/2")

Size (mm)	Size (inch)
150	6

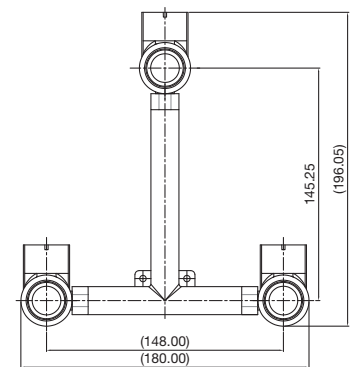



# WALL MIXER



**HOT SIDE & COLD SIDE**  
20mm (3/4") X 15mm (1/2")

Size (mm)	Size (inch)
150	6

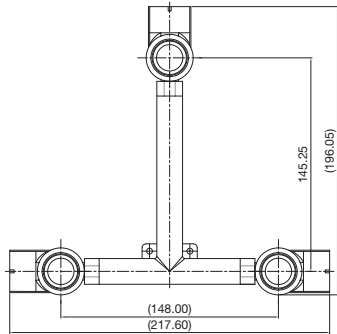

**HOT SIDE & COLD DOWN**  
20mm (3/4") X 15mm (1/2")

Size (mm)	Size (inch)
150	6

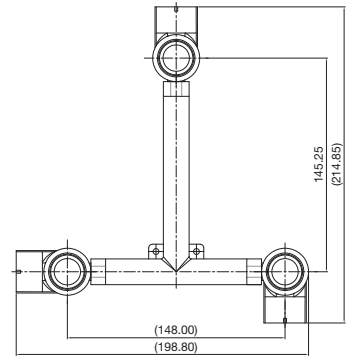

**HOT DOWN & COLD SIDE**  
20mm (3/4") X 15mm (1/2")

Size (mm)	Size (inch)
150	6

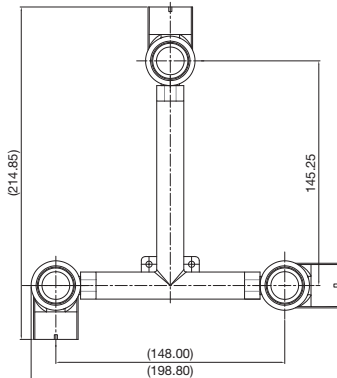

**HOT UP & COLD DOWN**  
20mm (3/4") X 15mm (1/2")

Size (mm)	Size (inch)
150	6

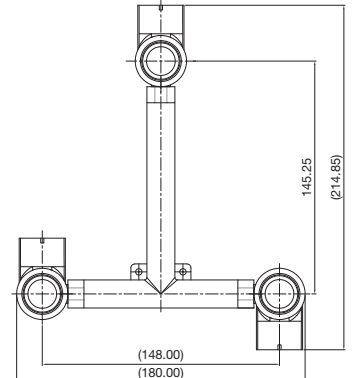

**HOT DOWN & COLD UP**  
20mm (3/4") X 15mm (1/2")

Size (mm)	Size (inch)
150	6

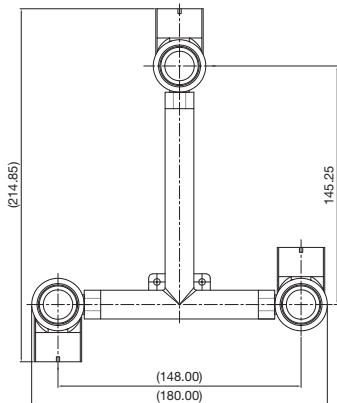

# SOLVENT CEMENT

WORLD'S FIRST CPVC CEMENT WITH 3 YEAR SHELF LIFE##

## TUBE (YELLOW)



Size (ml)
29.5
59

## TIN (YELLOW)



Size (ml)
59
118
237
473
964

## TIN\*\* (HEAVY)



Size (ml)
59
118
237
473
964

## PRIMER CLEAR\*\* (TIN)



Size (ml)
118
237
473
964

\*\*Non FlowGuard Plus Product

##Applicable for unopened cans from the date of manufacturing

# QUALITY CONTROL

All pipes and fittings at Prince Pipes undergo stringent testing for strict control of quality in order to ensure that only the best product reaches its customers. Some of the tests that are performed in-house are:

## RAW MATERIALS

- Cell Classification Test
- Tensile Strength
- Modulus of Elasticity in Tension
- Izod Impact Strength
- Heat Deflection Temperature Under Load
- Density
- Color

## FITTINGS

- Visual Appearance
- Dimensions
- Heat Distortion Test
- Thermocycling Test
- Torque Test
- Burst Pressure Test

## PIPES

- Visual Appearance
- Dimensions and Ovality
- Tensile Strength Test
- Hydrostatic Pressure Test - Short Term & Long Term
- Drop Impact Test
- Heat Reversion Test
- Opacity Test
- UV Stability Test
- Vicat Softening Temperature Test
- Maximum Burst Pressure Test

## COMPLETE SYSTEM TEST: ASSEMBLY OF PIPES & FITTINGS WITH SOLVENT CEMENT

- Quick pressure test at 23°C @ 36kg/cm<sup>2</sup> for 10 minutes.
- Malfunction test at 95°C @ 10kg/cm<sup>2</sup> for 1000 Hrs.
- Hydrostatic sustained pressure test at 82°C @ 28kg/cm<sup>2</sup> for 4 hours
- Effect on water
- Flattening Test



# THERMAL EFFECTS

## THERMAL EXPANSION & CONTRACTION

Like all piping materials CPVC expands when heated & contracts when cooled. Regardless of pipe diameter CPVC will expand about 75mm per 30 meter length when subjected to 40° C temperature variations. Hence allowances must be made for resulting change in movement. The fact that CPVC has higher thermal expansion than metal and sometimes cause unwanted concern. The stresses developed in CPVC pipe are generally much smaller than those developed in metal pipe for equal temperature changes because of the difference in elastic modulus.

Generally thermal expansion contraction can be accommodated with change in direction; however a long straight run may require an offset or expansion loop. Only one expansion loop properly sized is required in any single length straight run, regardless of its total length. If more convenient, two or more properly sized expansion loop can be used. For convenience, loop or offset lengths have been calculated for different pipe sizes and different run lengths with a temperature increase ΔT of 44°C (80°F). The results are shown in Table A for CTS pipes & Table B for IPS pipe. The results, shown in Table A & Table B are presented simply as a handy guide for quick and easy determinations of acceptable loop lengths for the approximate conditions.

### THERMAL EXPANSION FORMULA

$$\Delta L = L_P * C * \Delta T \quad \text{-----(Eq. 1)}$$

#### WHERE:

- $\Delta L$  = Change in length due to change in temperature (inch)
- $L_P$  = Length of pipe (inch)
- $C$  = Coefficient of thermal expansion (inch/inch/°F)  
= For CPVC =  $3.4 \times 10^{-5}$  inch/inch/°F
- $\Delta T$  = Change in temperature (°F)

### EXPANSION LOOP FORMULA

$$L = \sqrt{\frac{3 * E * D * (\Delta L)}{2S}} \quad \text{-----(Eq. 2)}$$

#### WHERE:

- $L$  = Loop length (inch)
- $E$  = Modulus of elasticity at maximum temperature (psi)
- $S$  = Working stress at maximum temperature (psi)
- $D$  = Outside diameter of Pipe (in.)
- $\Delta L$  = Change in length due to change in temperature (in.)

### EXPANSION LOOP DIAGRAM

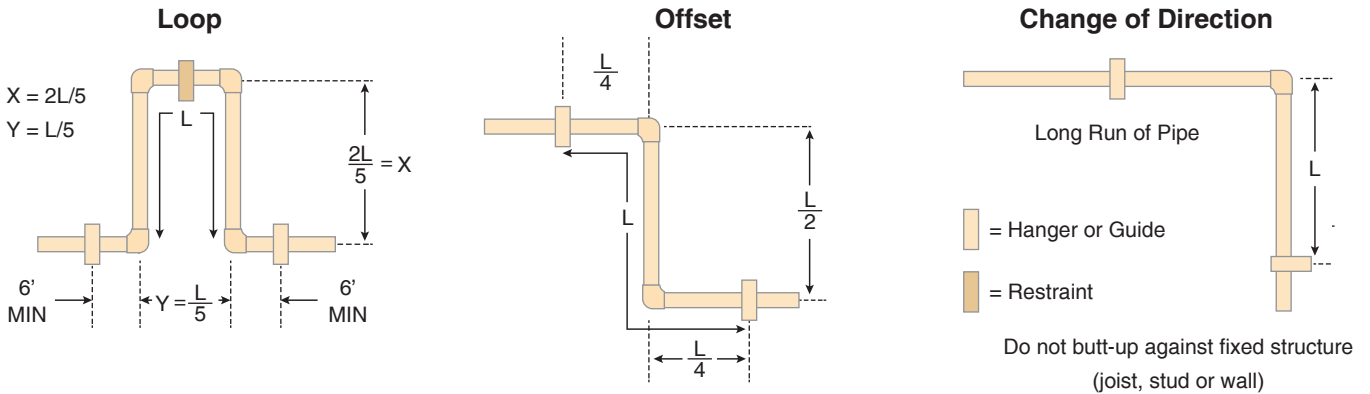

Note: The Clamp should be placed away from the elbows so that they do not restrict free movement of the pipe.

**TABLE A :** Flowguard CPVC CTC pipes as per ASTM D 2846 & IS 15778 (SDR 11) Calculated loop length with ΔT of about 80°F in inches

Nominal pipe size		Length of pipe run in feet			
Size (inch)	Size (mm)	40 (ft)	60 (ft)	80 (ft)	100 (ft)
1/2	15	22	27	31	34
3/4	20	26	32	36	41
1	25	29	36	41	46
1 1/4	32	32	40	46	51
1 1/2	40	35	43	50	56
2	50	40	49	57	64

**TABLE B :** Flowguard CPVC IPS pipes as per ASTM F 441 Calculated loop length with ΔT of about 80 °F in inches

Nominal pipe size		Length of pipe run in feet			
Size (inch)	Size (mm)	40 (ft)	60 (ft)	80 (ft)	100 (ft)
2 1/2	65	47	57	66	74
3	75	52	63	73	82
4	100	58	72	83	92
6	150	71	87	100	112
8	200	81	99	114	128
10	250	90	111	128	143
12	300	98	121	139	156

## MODULUS OF ELASTICITY AND WORKING STRESS FOR CPVC

Temperature in °C	Modulus of elasticity "E" in psi	Working stress "S" in psi
27	423000	2000
32	403000	1800
43	371000	1500
49	355000	1300
60	323000	1000
71	291000	750
82	269000	500

**Note :-**

Failure to compensate expansion and contraction caused by temperature change may result in system failure & property damage.

- Do not restrict expansion and contraction. Restraining movement in piping system is not recommended and may result in joint or fitting failure.
- Use supports or clamps which allow piping system movement.
- Align all piping system components properly without strain. Do not bend or pull pipe into position after being solvent welded.
- Do not terminate a pipe run against stationary object.
- Do not install fitting under stress.

## EXAMPLE CALCULATION FOR OFFSET LENGTH

Calculate the minimum offset required for a 60 feet long run of 1½" CPVC pipeline for a temperature change from 80°F to 160°F

**ANSWER:**

Using (Eq 1) calculate ΔL (Change in length due to temperature)

$$\Delta L = 60 \times 12 \times 3.4 \times 10^{-5} \times 80$$

$$\Delta L = 1.96 \text{ inch say } 2 \text{ inch}$$

Now using (Eq 2) find out "L" loop/offset length

$$L = \sqrt{\frac{3 \times 291000 \times 1.1625 \times (80)}{2 \times 750}}$$

$$L = 43.0 \text{ inch}$$

Answer & conclusion - The L calculated is consistent with the values given in Table A

## HORIZONTAL AND VERTICAL SPACING

According to plumbing codes & building codes a typical hot & cold water distribution system operating at 70°C requires support for sizes 1/2" to 1" horizontal line at every 90 cm and for sizes greater than 1" sizes at every 120cm. However, the following spacing given in below table are based on conservative engineering assumptions & recommended to be used at respective temperatures indicated.

Size (inch)	Size (mm)	68°F (ft)	20°C (mtr)	122°F (ft)	50°C (mtr)	158°F (ft)	70°C (mtr)	176°F (ft)	80°C (mtr)
1/2	12.70	5.5	1.7	4.5	1.4	3.0	0.9	2.5	0.8
3/4	19.05	5.5	1.7	5.0	1.5	3.0	0.9	2.5	0.8
1	25.40	6.0	1.8	5.5	1.7	3.5	1.1	3.0	0.9
1 1/4	31.75	6.5	2.0	6.0	1.8	3.5	1.1	3.0	0.9
1 1/2	38.10	7.0	2.1	6.0	2.0	3.5	1.1	3.5	1.1
2	50.80	7.0	2.1	6.5	2.0	4.0	1.2	5.5	1.1
2 1/2	63.50	8.0	2.4	7.5	2.3	4.5	1.4	4.0	1.2
3	76.20	8.0	2.4	7.5	2.3	4.5	1.4	4.0	1.2
4	101.60	9.0	2.7	8.5	2.6	4.5	1.4	4.5	1.4
6	152.40	10.0	3.0	9.0	2.7	5.5	1.7	5.0	1.5

Pipe should not be anchored tightly by support, but secured in manner to allow for movement caused by thermal expansion contraction. Ensure supports and hangers shall not have sharp edges. Use supports and hangers which are chemically compatible with CPVC material.

## EXPANSION AND CONTRACTION

For CPVC pipes which are not embedded inside the wall but are carrying hot water from boiler/ solar water heater etc., it is important to make provision for expansion loop for every 12 feet run of the pipe, between two fixed joints.

For longer lines and longer distances, kindly refer to the below link for calculations or call our executive.

<https://www.flowguard.com/en-in/resources>



Use only one brand in expansion loop between two consecutive fixed joints.

### CARRYING HOT WATER FROM SOLAR HEATING SYSTEM

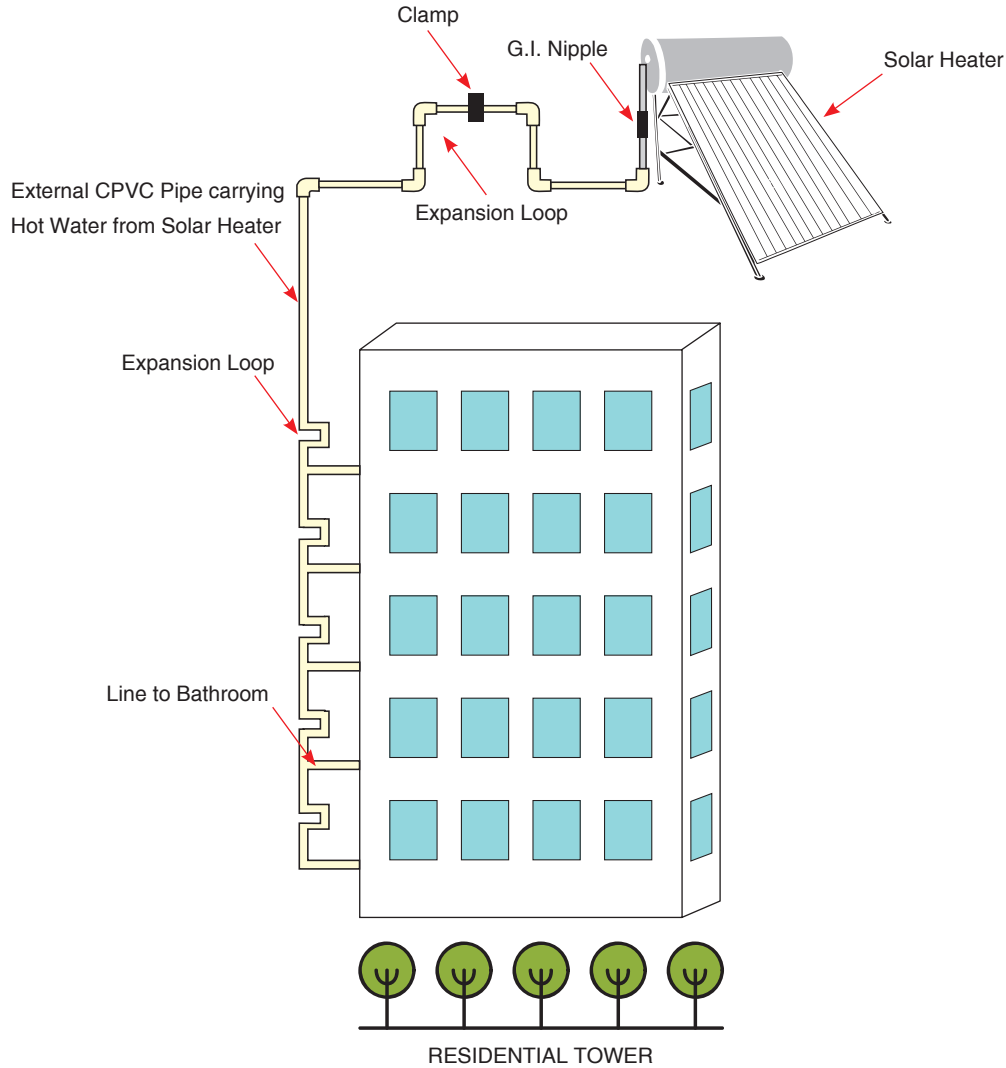

## CORRECT INSTALLATION IN SOLAR WATER HEATER LINES



It is not recommended to directly connect CPVC pipes to the water heater outlet.

One meter long metal nipple should be connected directly to the heater so that the CPVC pipe is not damaged by the buildup of excessive radiant heat from the flue.

## HEAT LOSS PREVENTION



In closed loop systems or plumbing systems with long run lengths, in order to conserve energy, it is recommended to use appropriate and compatible thermal insulation material.



# FLUID HANDLING CHARACTERISTICS OF PRINCE FLOWGUARD PLUS CPVC PIPING SYSTEM

## LINEAR FLUID FLOW VELOCITY

The linear velocity of fluid flow in PRINCE FLOWGUARD CPVC is calculated from following equation:

$$V = \frac{0.4085 \cdot g}{d^2} \text{-----(Eq. 3)}$$

Linear fluid flow velocity in any CPVC piping system should generally be limited to 5.0 feet/second. This will minimize the risk hydraulic shock failure which is concern of water hammer surge pressure.

### WHERE:

- V = Linear fluid flow velocity in feet per second
- g = Flow rate in gallons per minute
- d = Inside diameter of pipe in inches

## FRICTION LOSS IN PIPE

The Hazen-william equation is generally used for calculating frictional head loss in any piping system. The “C” value which is surface roughness constant for PRINCE Flowguard CPVC pipes is 150. As CPVC pipes are resistant to scaling & fouling means that friction pressure losses in the flow of fluid are very negligible against the metal pipes subject to scaling.

$$f = 0.2083 \cdot \left( \frac{100}{C} \right)^{1.852} \cdot \frac{g^{1.852}}{d^{4.8655}} \text{-----(Eq. 4)}$$

### WHERE:

- f = frictional head loss in feet for water per 100 feet length of CPVC pipe
- d = inside diameter of pipe in inches
- g = flow rate in gpm (gallons per minute)
- C = surface roughness constant for pipe

Surface roughness constant “C” for different piping materials

“C” Surface roughness constant	Pipe type
150	CPVC pipe
130-140	New steel, CI & Copper pipes
120	Old steel, CI & Copper pipes
110	GI (galvanized) pipes
60 - 80	Worn/pitted CI pipes

## FRICTION LOSS IN FITTINGS

Frictional losses through various types of injection moulded CPVC fittings are calculated from the equivalent length of straight pipe. The equivalent lengths of pipe for various common CPVC fittings for frictional loss are given in below table.

Nominal Size (inch)	90° Elbow	45° Elbow	Tee straight run flow	Tee branch flow
1/2	1.55	0.83	1.04	3.11
3/4	2.06	1.10	1.37	4.12
1	2.62	1.40	1.75	5.25
1 1/4	3.45	1.84	2.30	6.90
1 1/2	4.03	2.15	2.68	8.05
2	5.17	2.76	3.45	10.3
2 1/2	6.10	3.30	4.10	12.20
3	7.60	4.10	5.10	15.20
4	10.00	5.30	6.70	20.00
6	15.10	8.00	10.10	30.20

# PIPES FRICTION LOSS

## FRICTION LOSS TABLE FOR CPVC SDR 11 PIPES AS PER IS 15778

Flow in lpm	Velocity in m/s	Pressure loss in mbar/meter	Velocity in m/s	Pressure loss in mbar/meter	Velocity in m/s	Pressure loss in mbar/meter	Velocity in m/s	Pressure loss in mbar/meter	Velocity in m/s	Pressure loss in mbar/meter	Velocity in m/s	Pressure loss in mbar/meter
1/2" SDR 11		3/4" SDR 11		1" SDR 11		1 1/4" SDR 11		1 1/2" SDR 11		2" SDR 11		
4	0.58	3.532	0.27	0.595	0.16	0.177	0.11	0.068	0.08	0.031	0.04	0.008
8	1.16	11.911	0.54	2.006	0.32	0.595	0.21	0.230	0.15	0.103	0.09	0.028
12	1.74	24.280	0.80	4.086	0.48	1.211	0.32	0.468	0.23	0.209	0.13	0.058
16	2.32	40.274	1.07	6.773	0.64	2.004	0.43	0.775	0.31	0.346	0.18	0.096
20	2.90	59.667	1.34	10.026	0.80	2.964	0.54	1.146	0.38	0.512	0.22	0.141
24	-	-	1.61	13.818	0.96	4.082	0.64	1.577	0.46	0.705	0.27	0.194
28	-	-	1.88	18.129	1.12	5.350	0.75	2.066	0.54	0.923	0.31	0.255
32	-	-	2.14	22.941	1.28	6.763	0.86	2.612	0.61	1.167	0.36	0.322
36	-	-	2.41	28.241	1.44	8.318	0.97	3.211	0.69	1.434	0.40	0.396
40	-	-	2.68	34.018	1.60	10.009	1.07	3.863	0.77	1.725	0.44	0.476
60	-	-	-	-	2.41	20.428	1.61	7.875	1.15	3.514	0.67	0.968
80	-	-	-	-	-	-	2.15	13.062	1.53	5.825	0.89	1.604
100	-	-	-	-	-	-	2.69	19.351	1.91	8.623	1.11	2.372
150	-	-	-	-	-	-	-	-	2.87	17.611	1.67	4.836
200	-	-	-	-	-	-	-	-	-	-	2.22	8.022
250	-	-	-	-	-	-	-	-	-	-	2.78	11.886

## FRICTION LOSS TABLE FOR CPVC SDR 13.5 PIPES AS PER IS 15778

Flow in lpm	Velocity in m/s	Pressure loss in mbar/meter	Velocity in m/s	Pressure loss in mbar/meter	Velocity in m/s	Pressure loss in mbar/meter	Velocity in m/s	Pressure loss in mbar/meter	Velocity in m/s	Pressure loss in mbar/meter	Velocity in m/s	Pressure loss in mbar/meter
1/2" SDR 13.5		3/4" SDR 13.5		1" SDR 13.5		1 1/4" SDR 13.5		1 1/2" SDR 13.5		2" SDR 13.5		
4	0.53	2.945	0.25	0.525	0.15	0.151	0.10	0.058	0.07	0.026	0.04	0.007
8	1.05	9.931	0.50	1.772	0.29	0.507	0.20	0.197	0.14	0.088	0.08	0.024
12	1.58	20.243	0.75	3.608	0.44	1.032	0.30	0.400	0.21	0.179	0.12	0.050
16	2.10	33.573	1.00	5.979	0.59	1.709	0.40	0.662	0.28	0.297	0.16	0.082
20	2.63	49.734	1.25	8.851	0.74	2.527	0.49	0.979	0.35	0.439	0.20	0.121
24	-	-	1.50	12.199	0.88	3.479	0.59	1.348	0.42	0.604	0.25	0.167
28	-	-	1.75	16.003	1.03	4.559	0.69	1.766	0.49	0.791	0.29	0.219
32	-	-	2.01	20.250	1.18	5.764	0.79	2.232	0.56	1.000	0.33	0.277
36	-	-	2.26	24.927	1.33	7.089	0.89	2.744	0.63	1.229	0.37	0.340
40	-	-	2.51	30.024	1.47	8.530	0.99	3.302	0.70	1.478	0.41	0.409
60	-	-	-	-	2.21	17.406	1.48	6.730	1.06	3.011	0.61	0.832
80	-	-	-	-	2.95	28.902	1.98	11.161	1.41	4.990	0.82	1.378
100	-	-	-	-	-	-	2.47	16.533	1.76	7.386	1.02	2.039
150	-	-	-	-	-	-	-	-	2.64	15.083	1.54	4.155
200	-	-	-	-	-	-	-	-	-	-	2.05	6.892
250	-	-	-	-	-	-	-	-	-	-	2.56	10.211

# PIPES FRICTION LOSS

## FRICTION LOSS TABLE FOR CPVC SCH 40 PIPES AS PER ASTM F 441

Flow in lpm	Velocity in m/s	Pressure loss in mbar/meter	Velocity in m/s	Pressure loss in mbar/meter	Velocity in m/s	Pressure loss in mbar/meter	Velocity in m/s	Pressure loss in mbar/meter	Velocity in m/s	Pressure loss in mbar/meter
2 1/2" SCH 40			3" SCH 40		4" SCH 40		6" SCH 40		8" SCH 40	
10	0.05	0.0098	0.04	0.0043	0.02	0.0016	0.01	0.0003	0.01	0.0001
15	0.08	0.0198	0.05	0.0088	0.03	0.0032	0.01	0.0007	0.01	0.0002
20	0.11	0.0328	0.07	0.0145	0.04	0.0053	0.02	0.0011	0.01	0.0004
25	0.14	0.0485	0.09	0.0215	0.05	0.0078	0.02	0.0017	0.01	0.0006
30	0.16	0.0668	0.11	0.0295	0.06	0.0107	0.03	0.0023	0.02	0.0008
35	0.19	0.0875	0.12	0.0387	0.07	0.0140	0.03	0.0030	0.02	0.0011
40	0.22	0.1105	0.14	0.0489	0.08	0.0177	0.04	0.0038	0.02	0.0014
45	0.24	0.1358	0.16	0.0601	0.09	0.0217	0.04	0.0047	0.02	0.0017
50	0.27	0.1634	0.18	0.0723	0.10	0.0261	0.05	0.0057	0.03	0.0020
60	0.32	0.2248	0.21	0.0994	0.12	0.0359	0.05	0.0078	0.03	0.0028
70	0.38	0.2945	0.25	0.1302	0.14	0.0471	0.06	0.0102	0.04	0.0036
80	0.43	0.3722	0.28	0.1646	0.16	0.0595	0.07	0.0129	0.04	0.0046
90	0.49	0.4575	0.32	0.2023	0.18	0.0731	0.08	0.0158	0.05	0.0056
100	0.54	0.5503	0.35	0.2433	0.20	0.0879	0.09	0.0190	0.05	0.0068
125	0.68	0.8137	0.44	0.3597	0.25	0.1299	0.11	0.0281	0.06	0.0100
150	0.81	1.1203	0.53	0.4951	0.31	0.1788	0.14	0.0387	0.08	0.0138
175	0.95	1.4683	0.61	0.6487	0.36	0.2342	0.16	0.0507	0.09	0.0180
200	1.08	1.8561	0.70	0.8198	0.41	0.2960	0.18	0.0641	0.10	0.0228
250	1.35	2.7466	0.88	1.2125	0.51	0.4376	0.23	0.0947	0.13	0.0337
300	1.62	3.7841	1.05	1.6698	0.61	0.6024	0.27	0.1303	0.16	0.0463
400	2.17	6.2777	1.40	2.7676	0.82	0.9978	0.36	0.2157	0.21	0.0766
500	2.71	9.3020	1.75	4.0973	1.02	1.4761	0.45	0.3189	0.26	0.1133
600	-	-	2.10	5.6474	1.22	2.0331	0.54	0.4390	0.31	0.1559

## FRICTION LOSS TABLE FOR CPVC SCH 80 PIPES AS PER ASTM F 441

Flow in lpm	Velocity in m/s	Pressure loss in mbar/meter	Velocity in m/s	Pressure loss in mbar/meter	Velocity in m/s	Pressure loss in mbar/meter	Velocity in m/s	Pressure loss in mbar/meter	Velocity in m/s	Pressure loss in mbar/meter
2 1/2" SCH 80			3" SCH 80		4" SCH 80		6" SCH 80		8" SCH 80	
10	0.06	0.0123	0.04	0.0054	0.02	0.0019	0.01	0.0004	0.01	0.0001
15	0.09	0.0251	0.06	0.0109	0.03	0.0038	0.01	0.0008	0.01	0.0003
20	0.12	0.0415	0.08	0.0181	0.05	0.0063	0.02	0.0014	0.01	0.0005
25	0.15	0.0614	0.10	0.0267	0.06	0.0094	0.02	0.0020	0.01	0.0007
30	0.18	0.0845	0.12	0.0368	0.07	0.0129	0.03	0.0028	0.02	0.0010
35	0.21	0.1106	0.14	0.0481	0.08	0.0169	0.03	0.0036	0.02	0.0013
40	0.25	0.1398	0.16	0.0608	0.09	0.0213	0.04	0.0046	0.02	0.0016
45	0.28	0.1718	0.18	0.0747	0.10	0.0262	0.04	0.0057	0.03	0.0020
50	0.31	0.2066	0.20	0.0899	0.11	0.0315	0.05	0.0068	0.03	0.0024
60	0.37	0.2844	0.24	0.1237	0.14	0.0434	0.06	0.0094	0.03	0.0033
70	0.43	0.3726	0.28	0.1620	0.16	0.0568	0.07	0.0123	0.04	0.0043
80	0.49	0.4708	0.32	0.2047	0.18	0.0718	0.08	0.0155	0.05	0.0055
90	0.55	0.5787	0.35	0.2517	0.20	0.0883	0.09	0.0191	0.05	0.0067
100	0.61	0.6961	0.39	0.3027	0.23	0.1061	0.10	0.0229	0.06	0.0081

Flow in lpm	Velocity in m/s	Pressure loss in mbar/meter	Velocity in m/s	Pressure loss in mbar/meter	Velocity in m/s	Pressure loss in mbar/meter	Velocity in m/s	Pressure loss in mbar/meter	Velocity in m/s	Pressure loss in mbar/meter
	2 1/2" SCH 80		3" SCH 80		4" SCH 80		6" SCH 80		8" SCH 80	
125	0.77	1.0294	0.49	0.4475	0.28	0.1569	0.12	0.0339	0.07	0.0120
150	0.92	1.4173	0.59	0.6160	0.34	0.2159	0.15	0.0466	0.09	0.0165
175	1.07	1.8576	0.69	0.8071	0.39	0.2828	0.17	0.0610	0.10	0.0216
200	1.23	2.3483	0.79	1.0201	0.45	0.3574	0.20	0.0771	0.11	0.0273
250	1.53	3.4753	0.98	1.5088	0.56	0.5284	0.25	0.1140	0.14	0.0403
300	1.84	4.7885	1.18	2.0780	0.68	0.7275	0.30	0.1569	0.17	0.0555
400	2.46	7.9454	1.58	3.4445	0.90	1.2049	0.40	0.2597	0.23	0.0918
500	-	-	1.97	5.0999	1.13	1.7826	0.50	0.3839	0.29	0.1357
600	-	-	-	--	1.35	2.4554	0.60	0.5285	0.34	0.1868

## PRESSURE DROP IN VALVES & STRAINERS

Pressure drop in valves is calculated using flow coefficient of valves. These flow coefficient values for valves to be obtained from valve manufacturer. Following equation is used for calculating pressure drop

$$P = \frac{G^2}{C_v^2} \text{-----(Eq. 5)}$$

### WHERE:

- P = pressure drop in psi
- G = flow rate in gallons per minute
- Cv = valve flow coefficient

## WATER HAMMER & SURGE PRESSURE

Whenever the flow rate of fluid in pipe is changed  
When the flow rate of a fluid in a pipeline is changed, the velocity of fluid changes, causing a pressure surge that is called as Surge pressure or Water hammer. Such surges take place wherever there is a change in direction in the pipe, but potentially more seriously, they may be generated by any of the following:

- Pump start or stop
- Trapped air in the system
- Fast opening or closing of valves

The longer the pipelines and faster the velocity, the greater the shock load will be. And this shock load can be of sufficient force to cause a failure in pipe, fitting or valve. For this due consideration must be given to it when designing a pipeline.

The maximum water hammer surge pressure may be calculated for PRINCE FLOWGUARD CPVC piping system from following equation,

$$P_{wh} = \frac{\rho \Delta V}{g_c} * \left\{ \frac{\rho}{g_c} * \left[ \frac{1}{K} + \frac{d}{bE} \right] \right\}^{-1/2} \text{-----(Eq. 6)}$$

### WHERE:

- Pwh = Maximum surge pressure (water hammer) in lbf/ft<sup>2</sup>
- ρ = fluid density in lb/ft<sup>3</sup>
- ΔV = change in fluid velocity in ft/sec.
- gc = dimensional constant or gravitational constant  $\left( \frac{32.2 \text{ lb*ft}}{\text{lb*S}^2} \right)$
- K = bulk modulus of elasticity of fluid in lbf/ft<sup>2</sup>
- d = inside pipe diameter in inches
- b = pipe wall thickness in inches
- E = pipe material bulk modulus of elasticity

### THE WATER HAMMER SURGE PRESSURE + THE SYSTEM OPERATING PRESSURE SHOULD NOT EXCEED 1.5 TIMES THE RECOMMENDED WORKING PRESSURE RATING OF THE SYSTEM.

In order to minimize hydraulic shock due to water hammer, linear fluid velocity should generally be limited to 5 feet/ second (1.5 meter/second). Velocity at system startup/testing should be limited to 1 feet/second during filling the system, until it is ensured that all entrapped air is removed from the system before startup or testing the system with pressure.

Air should not be allowed to accumulate in the system while it is operating. Pump should not be allowed to draw in air.

Where necessary; extra protective equipment may be used to prevent water hammer damage. Such equipment might include pressure relief valves, shock absorbers, surge arrestors and vacuum air relief valves.

# FLOWGUARD PLUS CPVC ONE STEP SOLVENT CEMENT



PRINCE PIPES IN ASSOCIATION WITH E-Z WELD, WORLD LEADERS IN SOLVENT CEMENTS. THIS SOLVENT CEMENT IS FAST-SETTING, MAKING THE INSTALLATION PROCESS QUICK AND EASY.



3-Year shelf life (unopened cans from the date of manufacturing)



For copper tube size CPVC hot and cold potable water pipe & fittings up to 2" Dia (50 mm) interference fit



Adherence to the parameters of ASTM D2846 and F493



Sets faster resulting in quicker installation



Environment friendly



NSF certified for solvent cement only

## SOLVENT CEMENT - HANDLING, CURING & NUMBER OF JOINTS

### AVERAGE HANDLING / SET UP TIMES+

Handling / Setup time is the time required prior to handling the joint carefully. In damp or humid weather, allow 50% additional cure time.

Temperature while joining	Pipe diameter 1/2" to 1 1/4" 15mm to 32mm	Pipe diameter 1 1/2" to 2" 40 mm to 50mm	Pipe diameter 2 1/2" to 5" 65mm to 125mm	Pipe diameter 6" to 8" 150mm to 200mm	Pipe diameter 10" to 16" 250mm to 375mm	Pipe diameter 16" + 400mm
16°C to 38°C (60°F to 100°F)	2 minutes	5 minutes	25 minutes	30 minutes	2 hours	4 hours
5°C to 16°C (40°F to 60°F)	5 minutes	10 minutes	50 minutes	2 hours	8 hours	16 hours
-18°C to 5°C (0°F to 40°F)	10 minutes	15 minutes	4 hours	10 hours	24 hours	48 hours

+This chart should be used as a general reference only as these figures are estimates based on testing done under laboratory conditions. Field working condition can vary significantly.

### AVERAGE JOINT CURE TIMES ++

Relative Humidity 60% or Less	Pipe diameter 1/2" to 1 1/4" 15mm to 32mm		Pipe diameter 1 1/2" to 2" 40mm to 50mm		Pipe diameter 2 1/2" to 8" 65mm to 200mm		Pipe diameter 10" to 15" 250mm to 375mm	Pipe diameter 16" + 400mm
Temperature While Joining and Curing	Up to 145 psi/ 10bar	145 to 363 psi/ 10bar to 25bar	Up to 145 psi/ 10bar	145 to 363 psi/ 10bar to 25bar	Up to 145 psi/ 10bar	145 to 363 psi/ 10bar to 25bar	Up to 100 psi/ 7bar	Up to 100 psi/ 7bar
16°C to 38°C (60°F to 100°F)	15 minutes	6 Hrs	30 minutes	12 hours	1 1/2 hrs	24 hours	48 hours	72 hours
5°C to 16°C (40°F to 60°F)	20 minutes	12 hrs	45 minutes	24 hours	4 hours	48 hours	96 hours	6 days
-18°C to 5°C (0°F to 40°F)	30 minutes	48 hrs	1 hour	96 hours	72 hours	8 days	8 days	14 days

++This chart should be used as a general reference only as these figures are estimates based on testing done under laboratory conditions. Field working condition can vary significantly.

## AVERAGE NUMBER OF JOINTS PER QUART CAN\*

Pipe Nominal Size	ASTM (in)	1/2	3/4	1	1 1/4	1 1/2	2	2 1/2	3	4	6	8	10	12	14	18
	ISO (DIN)	20	25	32	40	50	63	75	90	110	160	200	250	315	350	450
Number of Joints		300	200	125	105	90	60	50	40	30	10	6	2-3	1-2	3/4	1/2

\*This chart should be used as a general reference only as these figures are estimates based on testing done under laboratory conditions. Field working condition can vary significantly.

## BASIC PRINCIPLE OF SOLVENT WELDING

Solvent cement manufacturer Recommendations.

We strongly recommend users to follow the instructions and recommendation given by solvent cement manufacturer before use of solvent cement.

- **One Step Solvent Cement is recommended for pipe & fitting diameter up to 2" only, use yellow colour solvent cement for one step solvent cementing method.**
- **Two Step Solvent Cement is recommended for joining of pipes and fittings diameter 2.1/2" onwards, using initially primer followed by heavy duty orange colour solvent cement.**

To consistently make good joints using solvent cement, the following should be carefully understood and followed.

### ONE STEP SOLVENT CEMENTING PROCEDURE

1. The joining surface of socket & spigot must be softened and made semi-fluid.  
1/2" to 2" diameter pipes & fitting socket and spigot surface can be softened by using one step solvent cement (refer sketch 1).  
PRIMER IS NOT REQUIRED WITH ONE STEP SOLVENT CEMENT.

Marked areas must be softened and penetrated

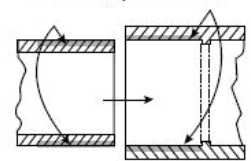

Sketch 1

2. Apply sufficient quantity of solvent cement to fill the gap between pipe and fitting.  
Sufficient one step cement to fill the loose part of joint must be applied. Besides filling the gap, adequate thick cement layers will penetrate the surface and also remain wet until the joint is assembled (refer sketch 2).
3. Assembly of pipe and fittings must be made while the surface are still wet and solvent cement is still fluid.

Cement coatings of sufficient thickness

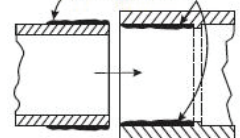

Sketch 2

4. If the one step solvent cement coating on the pipes and fittings are wet and fluid when assembly take place, they will tend to flow together and become one layer. Also, if the cement is wet, the surfaces beneath them will still be part of joint and these softened surfaces in the tight part of the joint will tend to fuse together (refer sketch 3).

Surfaces must be assembled while they are wet and soft



Sketch 3

4. Joint strength develops as the cement dries. In the tight part of the joint, the surface will tend to fuse together; in the loose part, the cement will bond to both surfaces.

As the solvent dissipates, the cement layer and the softened surfaces will harden with a corresponding increase in joint strength. A good joint will take the required working pressure long before the joint fully cured & become dry and final strength can be obtained (refer sketch 4). In the tight fused part of the joint strength will develop more quickly than loose fused part of joint. The development of bond strength information about solvent cement joint is discussed in further pages of this technical manual.

Bonded Surfaces

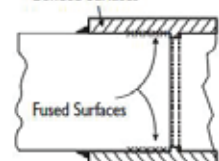

Sketch 4

Remember solvent cement weld joint shall not be disturbed until the joint fully cured.



# JOINTING PROCEDURE

1. Take the desired diameter of CPVC pipe which needs to be solvent welded. Before cutting inspect the pipe prior to marking and cutting. Mark the required length with the help of marker and measuring tape on pipe. Cut the pipe with the help of hack saw/carpenter saw. Ensure cut should be square to pipe axis.
2. Clean the cutting bur with the help of file/knife, make a chamfer on external edge of pipe with the help of saw. Clean the pipe with the help of cloth. Ensure no cutting bur dust remain inside of the bore of pipe.
3. Take the CPVC fitting which is going to be welded with the pipe. Measure the socket length & mark it on pipe end which need to be jointed with fitting. Clean the fitting with dry cloth. Ensure no moisture shall remain on pipe external end and fitting inside bore.
4. Check for dry fitment of pipe and fitting. pipe should enter fitting socket 2/3<sup>rd</sup> length easily and till the fitting socket end tightly up to mark which was marked with marker pen.
5. Use only PRINCE CPVC solvent cement for one step and two step solvent welding joint.

## ONE STEP SOLVENT CEMENTING PROCEDURE

- Apply solvent cement even coat to the pipe spigot to equal depth of fitting socket. Remember the amount of solvent cement should be sufficient to fill the gap between spigot and socket. Repeat the procedure of applying solvent cement again to pipe spigot and fitting socket.

Avoid splashing of solvent cement on unwanted area of pipe and fitting

- While pipe spigot and fitting socket are still wet, immediately insert the pipe into the fitting socket with rotating the pipe 1/4th turns till it touches to bottom of fitting with proper alignment. Ensure pipe must bottom completely too fitting end. Hold the assembly for 30 seconds for initial bonding.

Holding for 30 second is necessary due to tapered interference fitment of socket otherwise pipe may come back again.

- An even bead of solvent cement around assembled joint area assures a perfect joint. It is the indication of sufficient solvent application for joint.

If bead is not form evenly around the joint juncture means solvent cement is insufficiently applied. In this situation joint must be discarded and joint must be begun again by cutting the discarded joint.

- Wipe the solvent cement excess bead with a cotton cloth/rag.
- Allow the assembled solvent cement joint to be set and cured

## TWO STEP SOLVENT CEMENTING PROCEDURE

- The meaning of two step solvent cementing is to apply primer initially to prepare surface for making good joint followed by solvent cement.

Primer must be applied on the surface of pipes spigot and fitting socket to prepare bonding area for the addition of solvent cement and subsequent assembly. Use proper size swab/brush for applying primer.

- First apply primer to fitting inside of socket surface then to the pipe external spigot surface end. Again apply primer second coat to fitting socket and pipe spigot. This repeated application is necessary to keep surface need to be welded wet. Ensure primer should not be splashed

Ensure splashing of primer and solvent cement within fitting surface and external pipe spigot surface where softening is not needed, this may cause damage.

- Apply solvent cement even coat to the pipe spigot to equal depth of fitting socket and fitting socket immediately while primer is still gluey. Remember the amount of solvent cement should be sufficient to fill the gap between spigot and socket. Repeat the procedure of applying solvent cement again to pipe spigot and fitting socket.

Avoid splashing of solvent cement on unwanted area of pipe and fitting.

- While pipe spigot and fitting socket are still wet, immediately insert the pipe into the fitting socket with rotating the pipe 1/4th turns till it touches to bottom of fitting with proper alignment. Ensure pipe must bottom completely too fitting end. Hold the assembly for 30 seconds for initial bonding.

Holding for 30 second is necessary due to tapered interference fitment of socket otherwise pipe may come back again.

- An even bead of solvent cement around assembled joint area assures a perfect joint.  
If bead is not form evenly around the joint juncture means solvent cement is insufficiently applied. In this situation joint must be discarded and joint must be begun again by cutting the discarded joint.
- Wipe the solvent cement excess bead with a cotton cloth/rag.
- Allow the assembled solvent cement joint to be set and cured.

## TIPS FOR SOLVENT CEMENTING

### IN HOT WEATHERS

- A. Store solvent cement in cool place or shaded area prior to use.
- B. If possible, store pipes & fittings, or end of the pipes to be solvent welded, in shaded area before using for solvent cementing.
- C. Carry-out the solvent cement jointing activity under shaded area.
- D. Wipe the surface of pipes & fitting which is to be joined with the help of cloth/rag. Ensure the surfaces are dry prior to applying solvent cement.
- E. Try to do the solvent cementing jointing in cool morning hours.
- F. Ensure that the pipe spigots and fitting sockets to be joined are still wet with solvent cement before inserting pipe spigot in fitting socket.
- G. Before using solvent cement shake the container and stir the solution with swab/brush.
- H. Final anchoring of CPVC piping system shall be carried in cooler hours of the day on account of expansion and contraction phenomenon.

### IN COLD WEATHERS

- A. Prefabricate system as much as possible in warm work area.
- B. Store solvent cement in warm area and make sure it remain in fluid condition.
- C. Special care to be taken to remove moisture from pipes and fittings which are to be welded with solvent cement.
- D. Allow longer cure time to the joints of the system before put them in operation.

## BEFORE TESTING THE INSTALLATION

1. Only water is recommended for conducting pressure test of installation; do not use air or any gases for pressure testing of installation.
2. The installation should be adequately anchored/clamped to limit the movement, because water under pressure exerts thrust force in piping system.
3. The piping system should be slowly filled with water, taking care to prevent surge and air entrapment.
4. The flow rate should not exceed 3.0 m / s.
5. All trapped air must be slowly released. Vents must be provided to at all high points of the piping system. All valves and relief mechanisms should be opened so that the air can be vented while the system is being filled. Trapped air is extremely dangerous and it must be slowly and completely vented prior to testing.
6. Once an installation is completed and cured the system should be filled with water and pressure tested in accordance with local code requirements. However, care must be taken to ensure the pressure of the lowest component in the system (valves, unions, flanges, threaded parts, etc. )
7. The pressure test up to one hour is sufficient. Any leaking joints or pipe must be cut out and replaced and the line recharged and retested using the same procedure.

# INSTALLATION AND COMMISSIONING

- a) Pipeline should be installed in proper alignment and along with necessary clamps.
- b) Pressure testing to be done before concealed work using clean water (preferably potable water).
- c) Pressure testing may be carried out after a curing period of 24 hours and should not be done before that.

---

## HANDLING AND STORAGE OF PRINCE FLOWGUARD PLUS CPVC PIPES, FITTINGS & SOLVENT CEMENT.

### HANDLING

1. On receipt of pipes and fittings, check & inspect for any damages during transportation. Inspect pipe and fittings ends for cracks or damage.
2. Do not drop pipe from truck and do not step on pipe.
3. Do not handle pipe carelessly during unloading, shifting, jointing practices etc. This may cause permanent damage to the pipe and fittings.
4. Do not drag or drop the pipe & fitting while unloading, shifting, etc.
5. Avoid contact of pipes & fittings contact with any sharp edges/object.

### STORAGE & SITE TRANSPORTATION

1. Pipe shall be stored under covered area to protect from sunlight & UV discoloring effect.
2. Pipe shall be stored on leveled flat ground which is free of sharp edged stones.
3. Suggest not stack different class pipes of same diameter together, if stacked different class pipes together, stack pipes having higher thickness at bottom & lower thickness above them.
4. Ideally pipe shall be stored on timber support of at least 100mm width & breadth and placed at a distance of 0.9 meters of interval with support from side.
5. The stacking height of pipe stack shall be less than 1.5 meter.
6. While transporting pipes at site using trollies, etc. ensure full length of pipe is supported on flat surface of trolley.
7. If various diameter and class of pipes need to be transported together, keep higher diameter and wall thickness pipes at bottom.

### HANDLING AND STORAGE OF SOLVENT CEMENT

1. Always keep solvent and primers in dry & cool place.
2. Does not use or store solvent cement near source of ignition like spark, heat, flame, open flame, etc.
3. Do not smoke, eat & drink when working with solvent cement for jointing.
4. Ensure work area is well ventilated; avoid breathing of solvent vapors which can pose serious safety hazards.
5. Keep containers of solvent & primers tightly closed except when the product is being used.
6. Follow instructions given on solvent and primer container by the solvent cement manufacturer.
7. Avoid contact with eye and skin. In case of eye contact, flush eye with water for 15 minutes and call physician immediately.
8. Do not use rags and bare hands to apply solvent cement: use swabs, brush, etc. to apply solvent cement.
9. Wear personal protection equipment like safety glass and solvent resistant gloves while working with solvents & primers.
10. Protect solvent cement from freezing, If solvent gels it should be discarded. Also its always recommended to conduct a drip test before usage of solvent cement..

Refer ASTM F 402 "Standard Practice for Safe Handling of Solvents, Primers and Cleaners Used for Joining Thermoplastic Pipe and Fitting".

# FREQUENTLY ASKED QUESTIONS

## DO PRINCE CPVC PIPES COME WITH UV PROTECTION?

FlowGuard Plus piping systems have been used exposed to sunlight for many years since inception and have shown no signs of deterioration even after many years of exposure to UV from the sunlight. However, some discoloration may occur after a few years of exposure, however, no change in the pressure bearing capacity of the FlowGuard system has been seen. We recommend painting the pipe with water-based/ latex paint to ensure no change in color. Please do not use oil/ solvent-based paints as these paints can drastically reduce the life of the system.

## WHAT ABOUT PIPES WITH CONCEALED INSTALLATIONS? CAN THE PUNCTURES BE REPAIRED & HOW?

Repair of the punctured and damaged pipes due to drilling/chiseling can be done by removing the adhesive plaster and using the pipe repair piece supplied by the company. Thoroughly clean the area of pipe damaged and make it dry. Apply solvent cement on the surface of the pipe's damaged portion along the circumference. Also, apply solvent adhesive on the inner surface of the pipe repair piece and snap it over the damaged area. Tie a small piece of string/binding wire around the repair piece and pipe for some time to allow it to set. This is a unique system available with CPVC pipe where the damaged pipe need not be cut or shifted back and forth for repair. Do a pressure test before replastering.

## HOW ABOUT THERMAL CONDUCTIVITY? DO CPVC PIPES NEED INSULATION?

The thermal conductivity of FlowGuard Plus CPVC pipes and fittings is 0.14 W/MK whereas the same of copper is 400 W/MK. Since CPVC is a very bad conductor of heat, light insulation is recommended only for installations where there is recirculation of hot water, this shall help in reducing the cost of reheating of water. In bathrooms with independent heaters within 3 meters location insulation may not be necessary.

Please ensure that the insulation material or glue which is being used to hold the insulation material does not contain any phthalate plasticizer as it is not compatible with CPVC and can cause failure to the plumbing system in the long run.

At the end of this section, a list of all incompatible materials with CPVC is given for ready reference.

## IS IT NECESSARY TO HAVE EXPANSION LOOPS IN HOT WATER LINES?

For CPVC pipes that are not embedded inside the wall but are carrying hot water from a boiler/ solar water heater, etc it is most important to use a ready-made expansion loop supplied by Prince Pipes. Use one readymade loop for every 9-12 ft. run of the pipe, between two fixed joints. The loops are designed for a max and min differential temp of 70°C. For longer lines and longer distances between the fixed joints expansion loops can be made at the site with calculations as per the FlowGuard Plus manual or existing available loops can be used after every 12 feet length of pipe.

## HOW HEALTHY AND RELIABLE IS A COMBINATION OF CPVC AND UPVC PIPES?

It is strictly advised to use CPVC pipes in all internal plumbing for both Hot and Cold water line. There have been instances of the nonreturn valve failure or pressure differential in the Hot and Cold water line due to which hot water has entered into the cold line. If the cold water line pipe is not temperature resistant then it will lead to leakage or bursting causing huge loss and inconvenience to the customer.

## IS IT REALLY SAFE TO DRINK WATER THAT PASSES THROUGH SOLVENT ADHESIVE JOINTS?

The solvent cement products comply with NSF/ANSI Standard 61 and NSF/ANSI Standard 372 and have been tested by NSF International. So, it is safe for drinking water applications.

## PUMP ROOM APPLICATIONS CAN BE COMPLICATED. ANY SUGGESTIONS ON THAT?

Any pump, when switched on, initially if generates very high pressure. This pressure may cause damage to initial fittings in the system. To avoid this damage following precautions to be followed:

- The ramp-up time to be increased. Because of increased ramp-up time, the pump gradually builds the pressure. This will not damage the initial fittings in the system.
- Immediately after the pump, 1st and 2nd fitting used should be of metal.
- After the metal bends, the pipe and fitting selection should be of Schedule 80, and jointing to be done with 2 step solvent cement.
- Proper supports to be used provided to avoid the sagging of piping.

## WATER HAMMER ARRESTOR (WHA)

WATER HAMMER is the term used to define the destructive forces, pounding noises, and vibration which develops in a piping system when a column of non-compressible liquid flowing through a pipeline is stopped abruptly. Fast closing positive shutoff valves incorporated in the plumbing system contribute to creating water shock which is not only annoying but damaging to pipes and appliances.

## FRICITION LOSS FORMULA

$$f = 0.2082 \times \left( \frac{100}{C} \right)^{1.852} \frac{g^{1.852}}{d^{4.8655}}$$

## WHERE:

- f = frictional head loss in feet for water per 100 feet length of CPVC pipe
- d = inside diameter of pipe in inches
- g = flow rate in gpm (gallons per minute)
- C = surface roughness constant for pipe

# WARRANTY

**PRINCE PIPES AND FITTINGS LIMITED** warrants to the original owner of the structure in which its CPVC Pipe and Fittings have been installed, that the Products will be free from manufacturing defects and conform to applicable standards under normal use. Buyer's remedy for breach of this warranty is limited to replacement of, or credit for, the defective product. This warranty excludes any expense for removal or reinstallation of any defective product and any other incidental, consequential, or punitive damages.

**This limited warranty is the only warranty made by seller and is expressly in lieu of all other warranties, express and implied, including any warranties of merchantability and fitness for a particular purpose.**

No statement, conduct or description by Prince Pipes or its representative, in addition to or beyond this Limited Warranty, shall constitute a warranty. This Limited Warranty may only be modified in writing signed by an officer of Prince Pipe.

## **This Limited Warranty will not apply if:**

1. The Products are used for purposes other than the transmission of domestic water.
2. The Products are not installed in good and workmanship consistent with normal industry standards; installed in compliance with the latest instructions published by Prince Pipes and good plumbing practices; and installed in conformance with all applicable plumbing and building code requirements.
3. Products of Prince Pipes are used with the products of other manufacturers.
4. The Products fail due to normal wear and tear or deficiencies in design, engineering, or installation of the water distribution system of which they are a part.
5. The Products have been the subject of modification; misuse; misapplication; improper maintenance or repair; damage caused by the fault or negligence of anyone other than Prince Pipe; or any other act or event beyond the control of Prince Pipes.
6. Improper storage, failure to observe the operating instructions, over stressing or overloading, unsuitable operating media, unsuitable construction work or unsuitable building ground.
7. The Products fail due to the freezing of water in the Products.
8. The Products fail due to contact with incompatible material list provided below.
9. Prince Pipe cannot accept responsibility for the performance, dimensional accuracy, or compatibility of pipe, fittings, gaskets, or couplings not manufactured or sold by Prince Pipes.
10. This Limited Warranty will not apply unless written notice of a claim is mailed to Prince Pipes at the address below within 30 days of the day of discovery of the allegedly defective product. Any Prince Pipes products alleged to be defective must be made available to Prince Pipes at the following address for verification, inspection and determination of cause:

### **PRINCE PIPES AND FITTINGS LIMITED**

The Ruby, 8th Floor, 29, Senapati Bapat Marg (Tulsi Pipe Road), Dadar (W), Mumbai - 400 028, Maharashtra, India.

Purchaser must obtain a return materials authorization and instructions for return shipment to Prince Pipes of any product claimed defective or shipped in error. Any Prince Pipes product proved to be defective in manufacture will be replaced F.O.C. point of original delivery, or credit will be issued, at the discretion of Prince Pipes.

# INCOMPATIBILITY

## **Note on incompatibility**

The following items are generally deemed incompatible with CPVC pipes and fittings as they can lead to environmental stress cracking or premature failure of the system. These materials are thus not to be used with Prince FLOWGUARD®PLUS™ CPVC pipes and fittings.

- Aggressive chemical agents
- Fire stopping systems
- Thread sealants
- Tiles and all purpose solvent cement caulk
- Vaseline
- Roofing tar
- Silicone pipe sealants
- Peppermint oil
- Dioctyl phthalate (instead use foam polyethylene)
- Lubricants such as WD40
- Insecticides
- Leak detectors
- Vegetable oil
- Solvent cement (other than CPVC)
- PVC pipe wrap tape
- Acrylic latex caoul and silicone
- Insulation materials with pthalate plasticiser

AUTHORISED DISTRIBUTOR :



Whatsapp No. +91-91670 39334

[www.princeenterprise.co.in](http://www.princeenterprise.co.in)

**PRINCE ENTERPRISE**

Add: Kasturi Complex, Gala No.K-1, Anjur Road Rahnal Village, Bhiwandi, Dist - Thane - 421302,

Office No. +91-7410078051 / 52 / 53.

Email: [princeenterprise1@gmail.com](mailto:princeenterprise1@gmail.com)