



SUPERIOR PERFORMANCE IN EXTREME TEMPERATURES

TECHNICAL MANUAL



APPROVED BY



GREENFIT[®]

PP-R Plumbing & Industrial Piping Systems

PRINCE[®]

PIPING SYSTEMS



**ZERO DEFECT
CHOICE**



Greener Better Together



Prince Pipes is not about creating products that are different but providing solutions that make a difference. From our zero defect manufacturing process that involves using recycled plastic to designing and equipping our plants with solar panels and various other energy saving manufacturing techniques, our endeavor has always been to further bring down the emission levels. Our strong belief in the concept of "better lasts longer" has not only helped us deliver premium quality products but also ensure lesser consumption. Together with our channel partners and plumbers, we are sure to leave a strong legacy for the generations to come.

THE JOURNEY

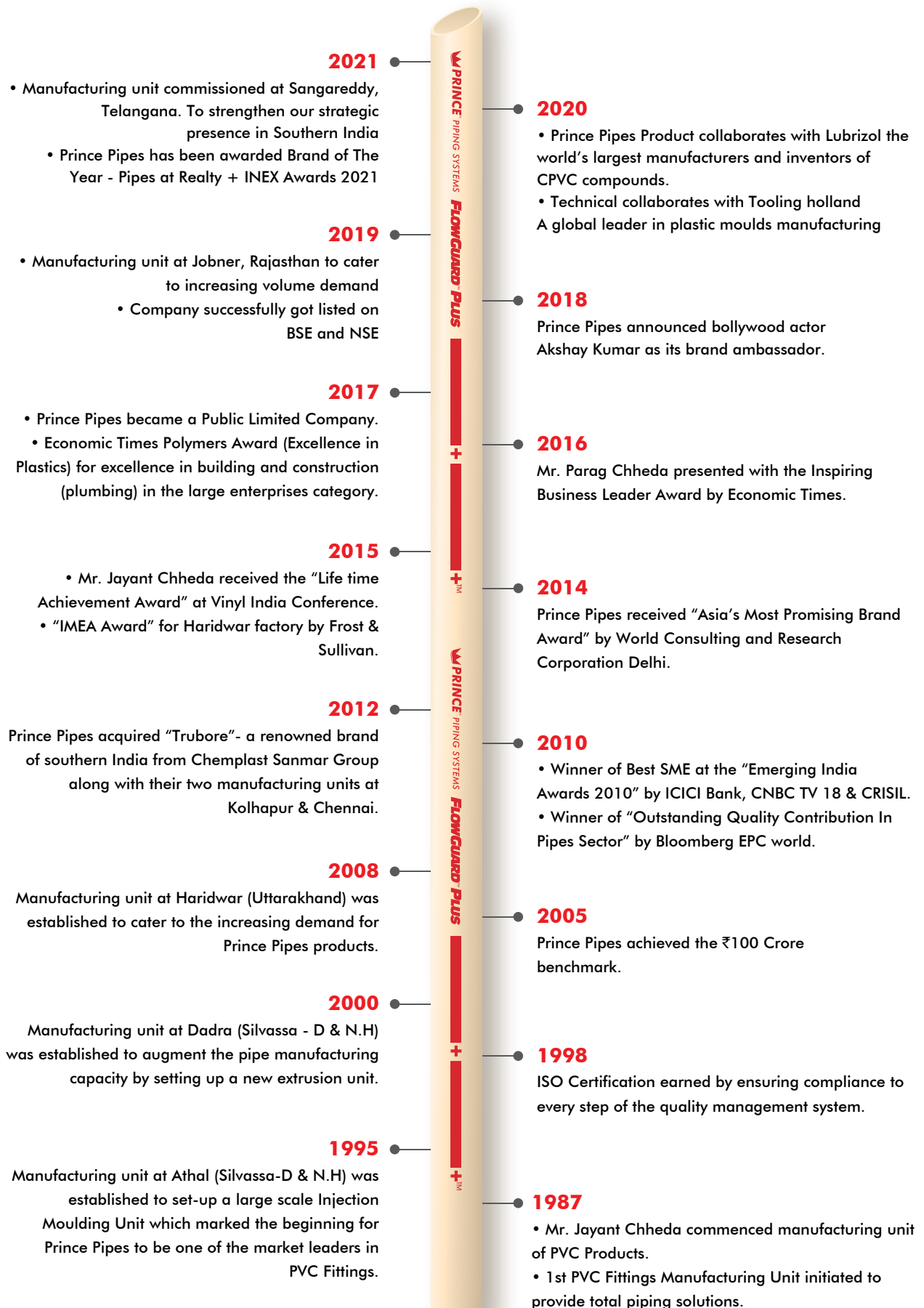

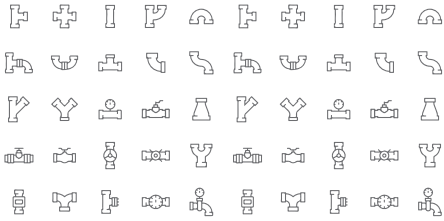

CONTENTS

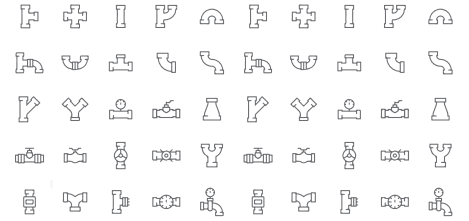

01

Manufacturing Units

02

Certifications

03

Greenfit PP-R Certifications

04

Introduction

06

Product Characteristics

07

Standard Working Conditions
& Service Life

08

Long Term Performance

09

- Reference Standards
- Types of PP-R Pipes

10

Features, Benefits & Applications

11

- Standards
- Pipes Dimensions

12

Fittings Dimensions

20

Brass Insert Fittings Dimensions

25

Accessories

26

Quality Assurance Tests

27

Technical Details

31

Design Guidelines

32

Pressure Loss Table

33

Joining Methods

34

DO's & DON'Ts

36

- Recommended Time for PP-R Fusion Joints
 - Hole Repairing
- Testing the Installation

37

Chemical Resistance Chart

53

Installation Images

MANUFACTURING UNITS



SANGAREDDY EST. 2021



JAIPUR EST. 2019



KOLHAPUR EST. 2012



CHENNAI EST. 2012



HARIDWAR EST. 2008



DADRA EST. 2000



ATHAL EST. 1995

CERTIFICATIONS



Realty+ INEX INTERIOR EXTERIOR EXCELLENCE AWARDS
CO-POWERED BY **Inmobel DOORE**

THIS CERTIFICATE IS PRESENTED TO
Prince Pipes & Fittings Limited
BRAND OF THE YEAR - WATER TECHNOLOGIES - PIPES

In recognition of your exemplary performance and achievement. Your efforts have contributed to making a positive difference in the Indian real estate industry.

Amrith Batra
DR. ANHURAG BATRA
Chairman & Editor-in-Chief
3W BusinessWorld & exchangeKnowledge Group

FEBRUARY 11, 2021

Certificate

Standard: **ISO 9001:2015**
Certificate Registr. No: **01 100 203083463**

Certificate Holder: **PRINCE**
PRINCE PIPES AND FITTINGS LTD
Survey No.132/1/1/2 Athal Road,
Village: Athal,Karoli, Shivasa- 392336,
Dadra & Nagar Haveli, India.

Scope: **Manufacture of uPVC, CPVC and HDPE Fittings.**

Validity: Proof has been furnished by means of an audit that the requirements of ISO 9001:2015 are met. The certificate is valid from 2021-05-28 until 2024-05-27.

2021-05-28

Amrith Batra
TUV Rheinland Cert GmbH
Am Green Street 51105 Köln

IAF DAKKS
www.tuv.com

TÜVRheinland
Precisely Right.

Certificate

Standard: **ISO 9001:2015**
Certificate Registr. No: **01 100 203083461**

Certificate Holder: **PRINCE**
PRINCE PIPES AND FITTINGS LTD
ghasara No 1546, 1549, 14 g &
Sakampur, Ghosla-2, Hardwar-249402,
Uttarakhand, India.

Scope: **Manufacture of uPVC, CPVC, PPR and HDPE Pipes and Fittings.**

Validity: Proof has been furnished by means of an audit that the requirements of ISO 9001:2015 are met. The certificate is valid from 2021-05-28 until 2024-05-27.

2021-05-28

Amrith Batra
TUV Rheinland Cert GmbH
Am Green Street 51105 Köln

IAF DAKKS
www.tuv.com

TÜVRheinland
Precisely Right.

Certificate

Standard: **ISO 9001:2015**
Certificate Registr. No: **01 100 2030834**

Certificate Holder: **PRINCE**
PRINCE PIPES AND FITTINGS LTD
The Ruby, 8th floor, 29, Senapati Bapat Marg (Tulsi Pipe Road), Dadar - West, Mumbai 400028, Maharashtra, India.

Scope: **Design, Development, Marketing, Procurement, Purchase/CAPEX, H.R., Logistics Management and Corporate Support Functions.**

Validity: Proof has been furnished by means of an audit that the requirements of ISO 9001:2015 are met. The certificate is valid from 2021-05-28 until 2024-05-27.

2021-05-28

Amrith Batra
TUV Rheinland Cert GmbH
Am Green Street 51105 Köln

IAF DAKKS
www.tuv.com

TÜVRheinland
Precisely Right.

Certificate

Standard: **ISO 14001:2015**
Certificate Registr. No: **01 104 2030834**

Certificate Holder: **PRINCE**
PRINCE PIPES AND FITTINGS LTD
The Ruby, 8th floor, 29, Senapati Bapat Marg (Tulsi Pipe Road), Dadar - West, Mumbai 400028, Maharashtra, India.

Scope: **Design, Development, Marketing, Procurement, Purchase/CAPEX, H.R., Logistics Management and Corporate Support Functions.**

Validity: Proof has been furnished by means of an audit that the requirements of ISO 14001:2015 are met. The certificate is valid from 2021-05-28 until 2024-05-27.

2021-05-28

Amrith Batra
TUV Rheinland Cert GmbH
Am Green Street 51105 Köln

IAF DAKKS
www.tuv.com

TÜVRheinland
Precisely Right.

Certificate

Standard: **ISO 45001:2018**
Certificate Registr. No: **01 213 2030834**

Certificate Holder: **PRINCE**
PRINCE PIPES AND FITTINGS LTD
The Ruby, 8th floor, 29, Senapati Bapat Marg (Tulsi Pipe Road), Dadar - West, Mumbai - 400028, Maharashtra, India.

Scope: **Design, Development, Marketing, Procurement, Purchase/CAPEX, H.R., Logistics Management and Corporate Support Functions.**

Validity: Proof has been furnished by means of an audit that the requirements of ISO 45001:2018 are met. The certificate is valid from 2021-05-28 until 2024-05-27.

2021-05-28

Amrith Batra
TUV Rheinland Cert GmbH
Am Green Street 51105 Köln

IAF DAKKS
www.tuv.com

TÜVRheinland
Precisely Right.

Certificate

Standard: **ISO 50001:2018**
Certificate Registr. No: **01 407 183634601**

Organization: **Prince Pipes and Fittings Ltd,**
Kasara No. 1546/1549 & 5, Sakampur/Meekood - 2, Industrial Park-2, Hardwar 249402 India

Site: **PRINCE**
PRINCE PIPES AND FITTINGS LTD
The Ruby, 8th floor, 29, Senapati Bapat Marg, (Tulsi Pipe Road), Dadar - West, MUMBAI-400028, India

Scope: **Design, Development, Marketing, Procurement, Purchase / CAPEX, H.R., Logistics Management and Corporate Support Functions.**

Validity: Proof has been furnished by means of an audit that the requirements of ISO 50001:2018 are met. This certificate is valid in conjunction with the main certificate 01 407 18363460 from 2021-05-21 until 2024-05-20.

2021-05-21

Amrith Batra
TUV Rheinland Cert GmbH
Am Green Street 51105 Köln

IAF DAKKS
www.tuv.com

TÜVRheinland
Precisely Right.

GREENFIT PP-R CERTIFICATIONS



Approval Number: 181259
Test Report: MATLAB 196 & 341

Water Regulations Advisory Scheme Ltd.
Unit 13,
Wilton Road,
For y Far Industrial Estate,
Quorn,
Leicestershire,
LE14 4GG

15th January 2017
Prince Pipes & Fittings Pvt. Ltd.
Khasra No-1548,
Salaspur Mehdood-2, Salaspur,
Bahadurabad,
Distt-Haridwar,
Uttarakhand-249402,
India

WATER REGULATIONS ADVISORY SCHEME LTD. (WRAS)
MATERIAL APPROVAL

The material referred to in this letter is suitable for contact with wholesome water for domestic purposes having met the requirements of BS6800-1:2000 and/or 2014 'Suitability of non-metallic products for use in contact with water intended for human consumption with regard to their effect on the quality of the water'.

The reference relates solely to its effect on the quality of the water with which it may come into contact and does not signify the approval of its mechanical or physical properties for any use.

POLYPROPYLENE - COMPONENTS 088

Prince Greenfit Triple Layer Pipe & Prince Greenfit Mono Layer Pipe. The mono layered pipe consists of a green coloured, moulded polypropylene single layer. The triple layered pipe consists of an extruded, white coloured polypropylene inner layer, a large coloured polypropylene middle layer & a green coloured polypropylene outer layer. For use with water up to 60 °C.

APPROVAL NUMBER: 181259
APPROVAL HOLDER: PRINCE PIPES & FITTINGS PVT. LTD.

The Scheme reserves the right to review approval.
Approval 181259 is valid between December 2016 and December 2021

As entry, as above, will accordingly be included in the Water Fittings Directory on file under the section headed, "Materials which have passed full tests of effect on water quality".

The Directory may be found at: www.wrass.co.uk/directory

Yours faithfully

Jason Farwell
Approvals & Enquiries Manager
Water Regulations Advisory Scheme

The Water Regulations Advisory Scheme Ltd. Registered in England No. 0900809 Registered Office: 87 Louth Street, Harlow Essex, SSM16 5JF
Tel: +44 (0)20 801 5800 Fax: +44 (0) 20 801 5801 Email: enquiries@wrass.co.uk



Approval Number: 181260
Test Report: MATLAB 342

Water Regulations Advisory Scheme Ltd.
Unit 13,
Wilton Road,
For y Far Industrial Estate,
Quorn,
Leicestershire,
LE14 4GG

15th January 2017
Prince Pipes & Fittings Pvt. Ltd.
Khasra No-1548,
Salaspur Mehdood-2,
Salaspur,
Bahadurabad,
Distt-Haridwar,
Uttarakhand-249402,
India

WATER REGULATIONS ADVISORY SCHEME LTD. (WRAS)
MATERIAL APPROVAL

The material referred to in this letter is suitable for contact with wholesome water for domestic purposes having met the requirements of BS6800-1:2000 and/or 2014 'Suitability of non-metallic products for use in contact with water intended for human consumption with regard to their effect on the quality of the water'.

The reference relates solely to its effect on the quality of the water with which it may come into contact and does not signify the approval of its mechanical or physical properties for any use.

POLYPROPYLENE - COMPONENTS 089

Prince Greenfit Fitting: Green coloured, injection moulded polypropylene fitting. For use with water up to 60 °C.

APPROVAL NUMBER: 181260
APPROVAL HOLDER: PRINCE PIPES & FITTINGS PVT. LTD.

The Scheme reserves the right to review approval.
Approval 181260 is valid between December 2016 and December 2021

As entry, as above, will accordingly be included in the Water Fittings Directory on file under the section headed, "Materials which have passed full tests of effect on water quality".

The Directory may be found at: www.wrass.co.uk/directory

Yours faithfully

Jason Farwell
Approvals & Enquiries Manager
Water Regulations Advisory Scheme

The Water Regulations Advisory Scheme Ltd. Registered in England No. 0900809 Registered Office: 87 Louth Street, Harlow Essex, SSM16 5JF
Tel: +44 (0)20 801 5800 Fax: +44 (0) 20 801 5801 Email: enquiries@wrass.co.uk



भारतीय मानक बोर्ड
BUREAU OF INDIAN STANDARDS
देहरादून शाखा कार्यालय
DEHRADUN BRANCH OFFICE

Address: UCF Sadan, Ground Floor,
Block- D, Deep Nagar Road,
Vishnu Vihar,
Dehradun - 248001
Phones : 761777270, 761777278
E-Mail: bis@bis.in
Web: <http://www.bis.org.in>
GST No. 05AAAT90433G1Z1H

प्रतीपत्तिसूची

इसका संदर्भ: DHBO/CML-3602447 दिनांक: 2 AUG 2021

विषय: धनुषजल मूहरोपन संख्या 3602447 का नवीनीकरण

M/s. Prince Pipes and Fittings Ltd.,
Khasra No.1548-1549-4&5,
Salaspur Mehdood-2 Off 50 meter Wide Road,
Bahadurabad, SIDCUL, Highway Road,
Distt-Haridwar,
Uttarakhand

सूचीकरण

1. प्रस्ताव अपने अधिसूचित नवीनीकरण आवेदन का अन्वेषण करे। इसे वह जानकारी देते हुए प्रस्तुत है कि आपके प्रस्तावत कार्यालय का दिनांक 01-08-2021 से 31-07-2022 तक नवीनीकरण हो गया है।
2. प्रस्ताव प्रसार में कि वह कार्यालय उपरोक्त विवरण सचिपि के साथ प्रसार हो जाएगा। जहां: अपने अनुदेश है कि जब प्रस्ताव कार्यालय नवीनीकरण अगले के लिए आवेदन सुन, सचिपि मूलक तब मूहरोपन मूलक के साथ अपने नवीनीकरण की विधि में कर में कर एक साथ पूरे अधिसूचित आवेदन करें।
3. कार्यालय नवीनीकरण के संदर्भ में प्रस्तावक नीचे संलग्न 14 संलग्न है। इसे प्रस्ताव अपने साथ प्रस्तुत मूल कार्यालय के साथ भेजें।

समाप्त

सचिव,

(सोहनमर उपचारण)
केसारीक- सी

संलग्न: संशोधन



भारतीय मानक बोर्ड
BUREAU OF INDIAN STANDARDS
देहरादून शाखा कार्यालय
DEHRADUN BRANCH OFFICE

Address: UCF Sadan, Ground Floor,
Block- D, Deep Nagar Road,
Vishnu Vihar,
Dehradun - 248001
Phones : 761777270, 761777278
E-Mail: bis@bis.in
Web: <http://www.bis.org.in>
GST No. 05AAAT90433G1Z1H

धनुषजल मूहरोपन एव / एन- 3602447 का संलग्न
Attachment to Licence No. CM/L- 3602447

सी एम/ एन संख्या CM/L-No	साधुसंस्था का एक वकिल Name of the Licensee with the Factory Address	उत्पाद का नाम Name of the Product	भारतीय मानक संख्या Indian Standard No.
3602447	M/s. Prince Pipes and Fittings Ltd., Khasra No.1548-1549-4&5, Salaspur Mehdood-2 Off 50meter Wide Road, Bahadurabad, SIDCUL, Highway Road, Distt- Haridwar, Uttarakhand	Polypropylene-random copolymer pipes for hot and cold water supplies -	IS 15801 : 2008

संलग्न संख्या 14 दिनांक
Endorsement No. 14 Dated 11.08.2021

धनुषजल 31 जुलाई 2021 तक प्रमाण है।
Whereas, the licence was valid upto Thirty First July Two Thousand Twenty One.

जब, नवीनीकरण के अधिसूचित, अनुदेश संख्या 13 में दिए गए धनुषजल की संख्या 01 संलग्न 2021 से 31 जुलाई 2022 तक बढ़ा दी गयी है।

Now, consequent upon renewal, the validity of the licence given in the Endorsement No. 13 has been extended from First August Two Thousand Twenty One to Thirty First July Two Thousand Twenty Two.

धनुषजल की शर्त एवं शर्तें बावत वही है।
Other terms and conditions of licence remain same.

सचिपि सचिपि के संलग्न,

सुधीर सिन्हा
केसारीक- ई एवं अनुदेश
(देहरादून शाखा कार्यालय)

INTRODUCTION

PREFACE

Progressive development of civilization results in people aspiring for better living standards. This can be met by using new materials in building industry which are more fit for use as well as more aesthetic than the traditional ones.

Today, the use of plastic products in construction as well as other industries is extremely widespread. Rapid changes in plastic raw materials and processing techniques provide advantages which cause these materials to be preferred in place of traditional construction and industrial application materials. One of these innovations is plumbing pipes and fittings produced out of POLYPROPYLENE RANDOM COPOLYMER (PPRC or commonly known as PP-R) material.

The superior physical characteristics of PP-R material, such as working temperatures up to 95°C, excellent chemical resistance as well as providing a definite solution to oxidation and calcification, make PP-R an ideal material, primarily for hot and cold water plumbing systems in buildings and industrial piping installations, ensuring a high quality performance.

PRINCE has been a leading manufacturer of uPVC piping systems since last 3 decades. Understanding the needs of the customer, PRINCE Piping Systems has established manufacturing of pipes, fittings & valves in PP-R material, using the best available technologies. PRINCE Piping Systems is proud to offer a complete range of high quality and reliable PP-R piping system for the modern construction industry.

WHY PRINCE GREENFIT PP-R

The primary advantages which make **GREENFIT PP-R** Piping Systems preferred over traditional ones are:-

Material Properties	Advantages
Lightweight	Easy to handle, transport and install. Saves Labour cost.
Better Corrosion Resistance	No scaling, can withstand higher 'pH' values.
Nontoxic, Hygienic 'Green product'	Safe for drinking water. No harmful effect to humans & ecology.
High Vicat Softening Temperature	Ensures thermal stability for hot water application.
UV resistant	Three layer pipes are suitable for outdoor installations, exposed to direct sunlight.
Good Thermal Insulation	Ensures lower heat losses & saves energy up to 15%
Good Chemical Resistance	Suitable for most of the industrial liquids.
Better Impact Strength	Higher stiffness than the standard pipes.
Heat Fusion Welding (no use of solvent)	Results in a homogeneous plastic system ensuring leak proof joint. Safe and reliable to use for concealed and exterior installations. Saves considerable jointing time.
Better Noise Insulation	Reduces water hammer sound.
Bacteriologically Neutral	Can be used underground. Also the fluid inside remains free from bacterial growth.
Very Less Coefficient of Friction	Low-pressure drop. Extremely high flow properties. Reduces pumping cost.
Resilience	Suitable for use in seismic areas.
Good Abrasion Resistance	Allow higher flow velocities of fluid up to 5 m/sec.
High Volume Resistivity	Poor conductor of electricity. No effect of stray currents.
Long life	Can exceed 50 years when operating under rated temperature and pressure conditions.
Linear Expansion	75% less linear expansion than standard pipes.

All the above advantages make PRINCE GREENFIT PP-R piping system the most cost effective solution compared to any other plumbing system.

COMPARISON BETWEEN DIFFERENT PIPING SYSTEMS

Property	Copper	CPVC	Galvanised Iron	HDPE	PRINCE GREENFIT PP-R
Type of joint	Soldering	Solvent welding	Threaded	Butt fusion	Poly-fusion welding. For transition joints, fittings with threaded metal inserts, are also available.
Installation	Time consuming & requires skill.	Easy to install, saves time & labour.	Tedious & time consuming.	Needs skilled labour.	Easy to install, saves time & labour.
Corrosion resistance	Not resistant	Free from corrosion.	Not resistant	Good	Free from corrosion.
Chemical resistance	Poor	Resistant to most of the chemicals.	Not resistant	Good	Excellent chemical resistance even at higher temperatures.
Scale formation	Common	No scaling	Very common	Inert to impurities in water	No scaling
Suitability in cold areas - sub-zero temperatures	Not suitable, Pipe bursts.	Impact strength considerably reduces at lower temperature & hence not suitable.	Not suitable. Pipe bursts.	Not suitable, Pipe cracks.	Most suitable due to typical elastic nature and good impact strength.
Insulation requirements	Essential	Not required	Essential	Required	Insulation is necessary at sub zero temperature.
Impact strength	Less	Less (brittle nature)	Excellent	Average	High impact strength.
Life span under rated pressure & temperature	20 - 30 years	30 - 40 years	5 -15 years	20-30 years	Can exceed 50 years.
Behavior in Fire	Resistant but de-shapes or punctures.	High percentage of chlorine and toxic gases are generated which are harmful.	Resistant	Not resistant	Melts like all other plastics, but no generation of any toxic gases.

PP-R IS AN IDEAL MATERIAL FOR HOT & COLD WATER PLUMBING SYSTEMS

PRODUCT CHARACTERISTICS

GREENFIT PP-R TECHNICAL SPECIFICATIONS

PHYSICAL PROPERTIES

Property	Test Method	Units	Value
Density, at 27°C	IS 12235 (Part 14)	Kg /m ³	900 - 910
Melt Flow Rate at 230° C/2.16 kg	IS 13360 Part 4/Sec 1	g/10 min	< 0.25
Viscosity	ISO 1191, ISO 1628 T3	-	-

THERMAL PROPERTIES

Property	Test Method	Units	Value
Thermal Conductivity	DIN 52612	W/m.K	0.24
Specific heat, at 23°C	Calorimeter	KJ/kg.K	2.0
Coefficient of linear expansion	DIN 53752	mm/M°C	1.5 x 10 ⁻⁴
VICAT Softening Temperature	ISO 306	°C	132
Melting Temperature Range	ISO 3146	°C	140 –150

MECHANICAL PROPERTIES

Property	Test Method	Units	Value
Tensile Stress at Yield (50mm/minute)	ISO 527-1, 2	MPa	24
Tensile Strain at Yield (50mm/minute)	ISO 527-1, 2	%	>50
Tensile modules (secant)	ISO 527-1, 2	MPa	850
Flexural Modulus	ASTM D 790	MPa	850
Tear Strength	ISO 527	MPa	40
Elongation at tear	ISO 527	%	800
Shore D Hardness	DIN 53 505	-	65
Pipe Friction factor	-	-	0.007
CHARPY Impact Strength - 23°C	ISO179/leA	KJ/m ²	22
0°C	ISO179/leA	KJ/m ²	4.0
-30°C	ISO179/leA	KJ/m ²	2.5

PHYSICAL PROPERTIES

Property	Test Method	Units	Value
Di electric constant	DIN 53483	-	2.3
Volume Resistivity	DIN 53482	Ohm-cm	> 1 x 10 ¹⁶
Di electric strength	DIN 53481	KV/mm	> 20

STANDARD WORKING CONDITIONS & SERVICE LIFE

Long-term performance curve shows the behavior of a pipe line depending on pressure and operating temperature. It establishes the average life expectancy of a pipe line as a function of hoop stress acting on the pipe walls. Hoop stress is in proportion with the pressure according to the following formula:

WHERE:

- δ = hoop stress (MPa)
- S_f = Safety factor
- p = Internal pressure (MPa)
- d = Outside diameter of pipe (mm)
- s = Wall thickness of pipe (mm)

$$\delta = S_f \times p \times \frac{(d-s)}{2s}$$

If we extrapolate the hoop stress from the long term performance curve and apply the formula using 1.5 safety factor, the admissible operating pressures are obtained as given in the tables.

ADMISSIBLE OPERATING PRESSURE

Temperature °C	Service Life in Years	Pipe Series according to DIN 8077/8078		
		SDR 11 - PN 10	SDR 7.4 - PN 16	SDR 6 - PN 20
		Safety-factor 1.5		
		Nominal pressure for PP-R pipes (kgs/cm ²)		
10°C	1	17.6	27.8	35.0
	5	16.6	26.4	33.2
	10	16.1	25.5	32.1
	25	15.6	24.7	31.1
	50	15.2	24.0	30.3
	100	14.8	23.4	29.5
20°C	1	15.0	23.8	30.0
	5	14.1	22.3	28.1
	10	13.7	21.7	27.3
	25	13.3	21.1	26.5
	50	12.9	20.4	25.7
	100	12.5	19.8	24.9
30°C	1	12.8	20.2	25.5
	5	12.0	19.0	23.9
	10	11.6	18.3	23.1
	25	11.2	17.7	22.3
	50	10.9	17.3	21.8
	100	10.6	16.9	21.2
40°C	1	10.8	17.1	21.5
	5	10.1	16.0	20.2
	10	9.8	15.6	19.6
	25	9.4	15.0	18.8
	50	9.2	14.5	18.3
	100	8.9	14.1	17.8

Temperature °C	Service Life in Years	Pipe Series according to DIN 8077/8078		
		SDR 11 - PN 10	SDR 7.4 - PN 16	SDR 6 - PN 20
		Safety-factor 1.5		
		Nominal pressure for PP-R pipes (kgs/cm ²)		
50°C	1	9.2	14.5	18.3
	5	8.5	13.5	17.0
	10	8.2	13.1	16.5
	25	8.0	12.6	15.9
	50	7.7	12.2	15.4
	100	7.4	11.8	14.9
60°C	1	7.7	12.2	15.4
	5	7.2	11.4	14.3
	10	6.9	11.0	13.8
	25	6.7	10.5	13.3
	50	6.4	10.1	12.7
	100	6.1	9.7	12.3
70°C	1	6.5	10.3	13.0
	5	6.0	9.5	11.9
	10	5.9	9.3	11.7
	25	5.1	8.0	10.1
	50	4.3	6.7	8.5
	100	3.9	6.1	7.7
80°C	1	5.5	8.6	10.9
	5	4.8	7.6	9.6
	10	4.0	6.3	8.0
	25	3.2	5.1	6.4
95°C	1	3.9	6.1	7.7
	5	2.5	4.0	5.0
	(10)*	(2.1)*	(3.4)*	(4.2)*

Explanations :

- = Recommended application - cold water installation
- = Recommended application - hot water installation
- = Recommended application - central heating installation

* Bracketed values apply where testing can be shown to have been carried out for longer than 1000 hours at 950°C

LONG TERM PERFORMANCE

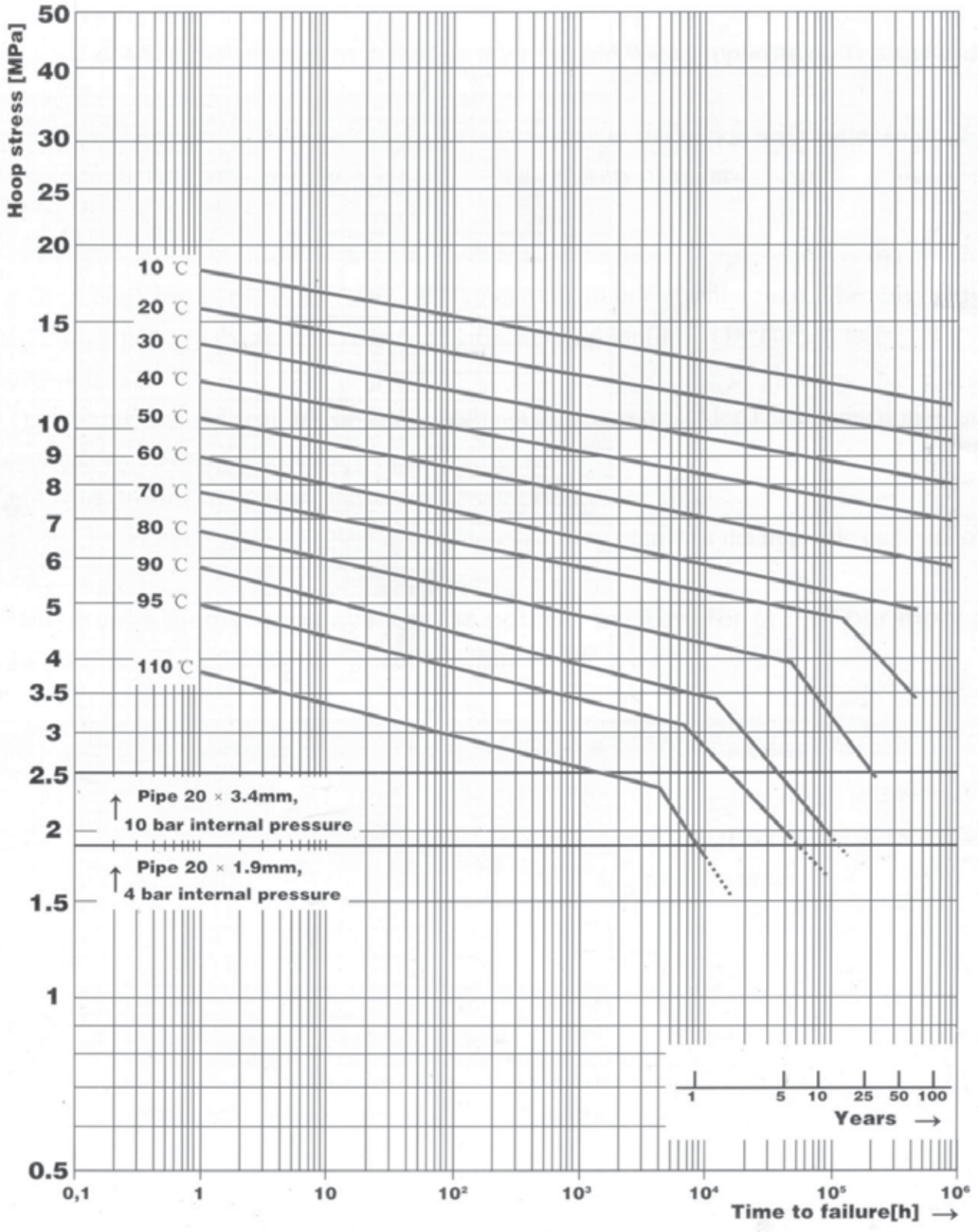

REFERENCE STANDARDS

Standards	
IS 15801	Polypropylene-Random Copolymer Pipes For Hot & Cold Water Supplies
DIN 16962	
a) Part 5	Pipe fittings and joint assemblies for polypropylene (PP) pressure pipes. General quality requirements and testing.
b) Part 6	Pipe joints and Elements for Polypropylene (PP) Pressure Pipelines. Types 1 and 2 Injection Moulded Elbows for Socket-welding Dimension.
c) Part 7	Pipe joints and Elements for Polypropylene (PP) Pressure Pipelines. Types 1 and 2 Injection Moulded Tee Pieces for Socket-welding Dimension.
d) Part 8	Pipe joints and Elements for Polypropylene (PP) Pressure Pipelines. Types 1 and 2 Injection Moulded Sockets & Caps for Socket-welding Dimension.
e) Part 9	Pipe joint assemblies and fittings for types 1 and 2 polypropylene (PP) pressure pipes. Injection moulded reducers & nipples for socket welding Dimensions.
f) Part 10	Pipe joint assemblies and fittings for types 1 to 3 polypropylene (PP) pressure pipes. Injection-moulded fittings for butt welding Dimensions.
IS 9845	Method of analysis for determination of specific and/or overall migration of constituents of plastic materials and articles intended to come into contact with foodstuffs.
IS 10500	Specification for polypropylene and its copolymers for its safe use in contact with food stuffs, Pharmaceuticals and drinking water.

TYPES OF PP-R PIPES

These pipes are used for conveying hot and cold water/fluids/chemicals/ compressed air in various plumbing installations such as,

- (A). Single layer (Green/ Blue Colour) Greenfit PP-R pipes for indoor installations.
- (B). 3 Layer Greenfit PP-R pipes for outdoor installations.
 - Outer layer (Green / Blue Colour) Greenfit PP-R is UV resistant, which makes the pipes suitable for usage under direct sunlight.
 - Inner layer (White Colour Greenfit PP-R is antimicrobial which adds to safety against inside bacterial growth.)
 - Middle layer (Off White Colour) Greenfit PP-R ensures the required strength of the pipes.
- (C). 3 Layer Greenfit PP-R thermax pipe has a specially formulated middle layer to reduce linear expansion of pipe due to temperature variance and to improve impact strength

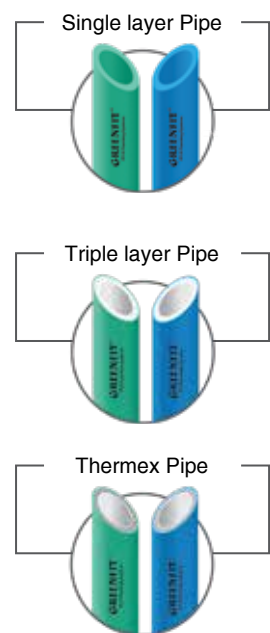

PP-R IS AN IDEAL MATERIAL FOR HOT & COLD WATER PLUMBING SYSTEMS

FEATURES AND BENEFITS FOR GREEN PP-R



Proven hot & cold water performance from -20°C to 95°C



No scaling. Can withstand higher 'pH' values



UV resistant triple layered pipes are suitable for outdoor installations that are exposed to direct sunlight



Good chemical resistance - suitable for most industrial liquids



Heat-fusion jointing results in homogenous plastic system ensuring leak-proof joints



Very less coefficient of friction, ensures high flow properties, reduce pumping cost



Antimicrobial inside layer of 3 layered pipe adds to safety against bacterial growth ensuring safe drinking water



Specially formulated thermex pipes reduce linear expansion / contraction of pipes due to temperature variance, ensuring suitability for outdoor application



Low maintenance cost.

APPLICATIONS FOR GREEN PP-R



Indoor & outdoor installations of hot & cold water piping systems in residential, commercial & buildings



Heating system inside buildings including floor, wall & radiator heating



Aggressive Chemicals & Pharmaceuticals Piping systems for conveyance of aggressive fluids in Industries



Solar water heating systems



Drinking water & liquid food transportation

FEATURES AND BENEFITS FOR BLUE PP-R



Proven hot & cold water performance from -20° C to 95°C



UV resistant triple layered pipes are suitable for outdoor installations that are exposed to direct sunlight



Heat-fusion jointing results in homogenous plastic system ensuring leak-proof joints



These joints are better than the conventional metal and aluminium joints



Smooth inner surface, ensuring least friction for the flowing air



Negligible creation of moisture leading to corrosion free pipes



Low thermal conductivity

APPLICATIONS FOR BLUE PP-R



Primary usages Compressed Air Lines



Secondary usages
- Instrument Air
- Nitrogen Air
- Vacuum Pipingwall

STANDARDS FOR PIPES AND FITTINGS

Pipes						
Type	Size (mm)	Working Pressure (Kg/cm ²)	Class	Standard	Colour	End Connection
Green PP-R	20 to 160	10, 16 & 20	SDR 11 (PN 10), SDR 7.4 (PN 16), SDR 6 (PN 20)	IS: 15801	<ul style="list-style-type: none"> • Single layer pipes - Green, • Triple layer pipe - Outer layer in green, inner layer in white • Thermex Pipe - Outer layer in green, middle layer in light grey, inner layer in white 	Poly-fusion welding joint
Blue PP-R					Triple layer pipe - Outer layer in Blue, inner layer in White	

Fittings					
Type	Size (mm)	Working Pressure (Kg/cm ²)	Standard	Colour	End Connection
Green PP-R	20 to 160	20 & 25	DIN:16962	Green	<ul style="list-style-type: none"> • Socket ends suitable for poly-fusion welding. • For transition joints, fittings with threaded metal inserts.
Blue PP-R				Blue	

PIPES DIMENSIONS

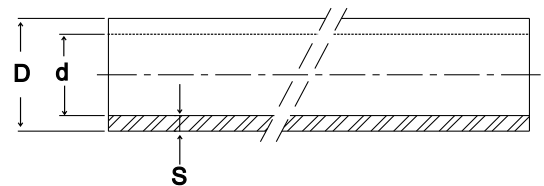

Nominal Bore		Outside Diameter (mm)	SDR 11 (PN-10)		SDR 7.4 (PN-16)		SDR 6 (PN-20)	
(mm)	(inch)		d (mm)	s (mm)	d (mm)	s (mm)	d (mm)	s (mm)
20	1/2	20.00	16.20	1.90	14.40	2.80	13.20	3.40
25	3/4	25.00	20.40	2.30	18.00	3.50	16.60	4.20
32	1	32.00	26.20	2.90	23.20	4.40	21.20	5.40
40	1 1/4	40.00	32.60	3.70	29.00	5.50	26.60	6.70
50	1 1/2	50.00	40.80	4.60	36.20	6.90	33.40	8.30
63	2	63.00	51.40	5.80	45.80	8.60	42.00	10.50
75	2 1/2	75.00	61.40	6.80	54.40	10.30	50.00	12.50
90	3	90.00	73.60	8.20	65.40	12.30	60.00	15.00
110	4	110.0	90.00	10.00	79.80	15.10	73.40	18.30
160	6	160.0	130.80	14.60	116.20	21.90	106.80	26.60

PP-R IS AN IDEAL MATERIAL FOR HOT & COLD WATER PLUMBING SYSTEMS

FITTINGS DIMENSIONS

Fusion Weld Joint



COUPLER

Size (mm)	ØD	L	Z	H
20	19.50	14.50	4.00	33.00
25	24.50	16.00	4.00	36.00
32	31.50	18.00	4.00	40.00
40	39.45	20.50	4.00	45.00
50	49.45	23.50	4.00	51.00
63	62.50	27.50	4.00	59.00
75	74.90	30.00	4.00	64.00
90	89.90	33.00	5.00	71.00
110	110.00	37.00	5.00	79.00
160	159.00	48.00	5.00	101.00

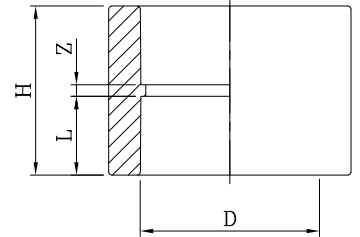

ELBOW 90°

Size (mm)	ØD	L	Z
20	19.50	14.50	11.00
25	24.50	16.00	13.50
32	31.50	18.00	17.00
40	39.45	20.50	21.00
50	49.45	23.50	26.50
63	62.50	27.50	32.50
75	74.90	30.00	41.00
90	89.90	33.00	48.50
110	110.00	37.00	58.00
160	159.00	48.00	26.00

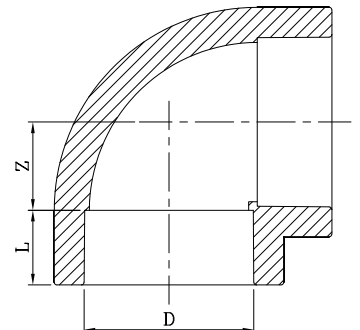

REDUCING ELBOW 90°

Size (mm)	ØD1	ØD2	L1	L2	Z1	Z2
25 X 20	24.50	19.50	16.00	14.50	13.50	15.00
32 X 25	31.50	24.50	18.00	16.00	17.00	19.00
32 X 20	31.50	19.50	18.00	14.50	17.00	20.50
40 X 32	39.45	31.50	20.50	18.00	21.00	20.50
40 X 20	39.45	19.50	20.50	14.50	21.00	20.50
40 X 25	39.45	24.20	20.50	16.00	21.00	25.50
63 X 40	62.50	39.45	27.50	20.50	32.50	39.50



ELBOW 45°

Size (mm)	ØD	L	Z
20	19.50	14.50	5.00
25	24.50	16.00	6.00
32	31.50	18.00	7.50
40	39.45	20.50	9.50
50	49.45	23.50	11.50
63	62.50	27.50	14.00
75	74.90	30.00	38.50
90	89.90	33.00	46.00
110	110.00	37.00	56.00
160	159.00	48.00	-

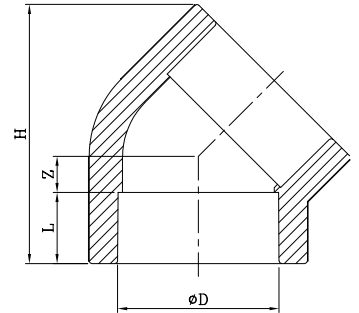

EQUAL TEE

Size (mm)	ØD	L	Z	H
20	19.50	14.50	11.00	51.00
25	24.50	16.00	13.50	59.00
32	31.50	18.00	17.00	70.00
40	39.45	20.50	21.00	83.00
50	49.45	23.50	26.50	100.00
63	62.50	27.50	32.50	120.00
75	74.90	30.00	38.50	137.00
90	89.90	33.00	46.00	158.00
110	110.00	37.00	56.00	186.00
160	159.00	48.00	24.00	150.00

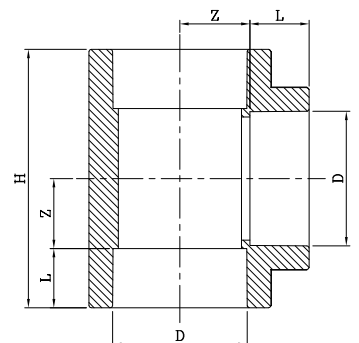

REDUCING TEE

Size (mm)	ØD1	ØD2	L1	L2	Z1	Z2	H
25 X 20	24.50	19.50	16.00	14.50	13.50	13.50	59.00
32 X 25	31.50	24.50	18.00	16.00	14.00	18.00	64.00
32 X 20	31.50	19.50	18.00	14.50	14.00	19.50	64.00

PP-R IS AN IDEAL MATERIAL FOR HOT & COLD WATER PLUMBING SYSTEMS



REDUCING TEE

Size (mm)	ØD1	ØD2	L1	L2	Z1	Z2	H
40 X 32	39.45	31.50	20.50	18.00	21.00	21.00	83.00
40 X 25	39.45	24.50	20.50	16.00	21.00	21.00	83.00
40 X 20	39.45	19.50	20.50	14.50	21.00	21.00	83.00
50 X 40	49.45	39.45	23.50	20.50	26.00	26.00	99.00
50 X 32	49.45	31.50	23.50	18.00	26.00	26.00	99.00
50 X 25	49.45	24.50	23.50	16.00	26.00	26.00	99.00
50 X 20	49.45	19.50	23.50	14.50	26.00	26.00	99.00
63 X 50	62.50	49.45	27.50	23.50	32.50	32.50	120.00
63 X 40	62.50	39.45	27.50	20.50	32.50	32.50	120.00
63 X 32	62.50	31.50	27.50	18.00	32.50	32.50	120.00
63 X 25	62.50	24.50	27.50	16.00	32.50	32.50	120.00
63 X 20	62.50	19.50	27.50	14.50	32.50	32.50	120.00
75 X 63	74.90	62.50	30.00	27.50	38.50	38.50	137.00
75 X 50	74.90	49.45	30.00	23.50	38.50	38.50	137.00
75 X 40	74.90	39.50	30.00	20.50	38.50	38.50	137.00
75 X 32	74.90	31.50	30.00	23.50	38.50	18.00	100.00
75 X 25	74.90	24.50	30.00	23.50	38.50	18.00	100.00
90 X 75	89.90	74.90	33.00	30.00	46.00	46.00	158.00
90 X 63	89.90	62.50	33.00	27.50	46.00	46.00	158.00
90 X 50	89.90	49.45	33.00	23.50	46.00	46.00	158.00
90 X 40	89.90	39.50	33.00	20.50	46.00	46.00	158.00
110 X 90	110.00	89.90	37.00	33.00	56.00	60.00	186.00
110 X 75	110.00	74.90	37.00	30.00	56.00	63.00	186.00
110 X 63	110.00	62.50	37.00	27.50	56.00	56.00	186.00
110 X 50	110.00	49.45	37.00	23.50	56.00	60.05	186.00
110 X 40	110.00	39.45	37.00	20.50	56.00	63.05	186.00
160 X 110	159.00	109.00	48.00	37.00	56.00	24.00	186.00

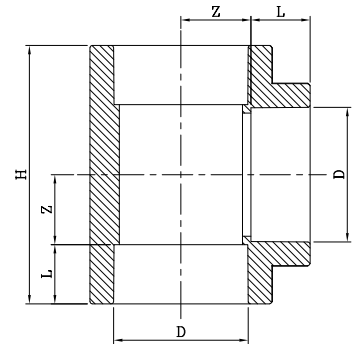

FOUR WAY TEE

Size (mm)	ØD	W	H
20	19.50	14.50	11.00
25	24.50	16.00	13.50
32	31.50	18.00	17.00

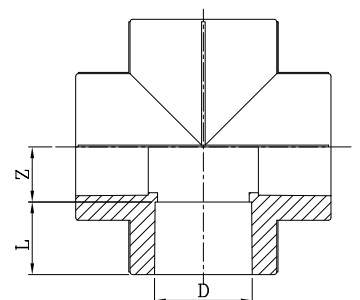



PLAIN UNION

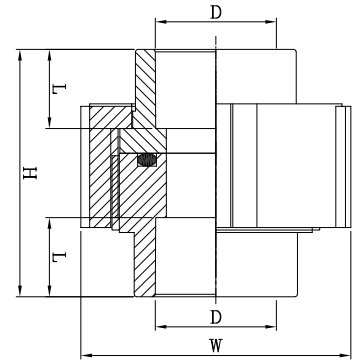

Size (mm)	ØD	L	H	W
20	19.50	14.50	47.00	48.00
25	24.50	16.00	50.00	55.00
32	31.50	18.00	49.50	67.50
40	39.45	20.50	79.00	77.30
50	49.45	23.50	100.30	90.50
63	62.50	27.50	84.00	125.00



END CAP

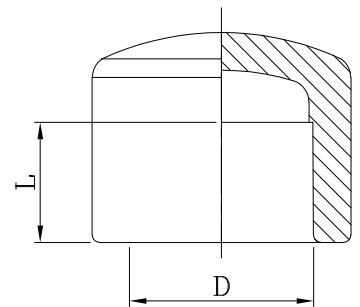

Size (mm)	ØD	L
20	19.50	14.50
25	24.50	16.00
32	31.50	18.00
40	39.45	20.50
50	49.45	23.50
63	62.50	27.50
75	74.90	30.00
90	89.90	33.00
110	110.00	37.00
160	159.00	48.00



END PLUG

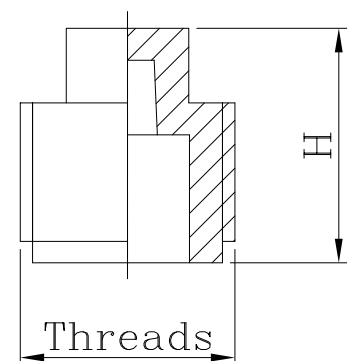

Size (mm)	Threads	H
20	1/2	22.50
25	3/4	25.00
32	1	28.00

PP-R IS AN IDEAL MATERIAL FOR HOT & COLD WATER PLUMBING SYSTEMS



EXTENDED END PLUG

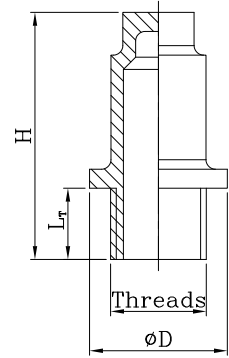

Size (mm)	ØD	Threads	L _r	H
20	27.00	1/2	15.00	65.00
25	35.00	3/4	16.00	53.00



CROSS OVER

(MOULDED)

Size (mm)	ØD	L	H	T
25	24.50	200.24	59.5	33.68
32	31.50	250.76	72.8	39.66

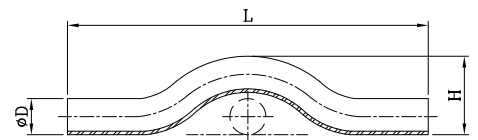

(FABRICATED)

Size (mm)	ØD	W	L
20	20.00	55.00	390.00
25	25.00	56.00	400.00
32	32.00	72.00	450.00



PIPE CLAMP

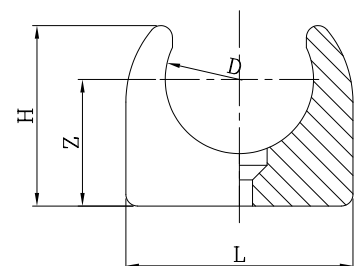

Size (mm)	ØD	H	L	Z
20	20.50	27.00	40.00	19.25
25	25.50	31.00	39.00	21.75
32	32.50	37.00	48.00	25.25

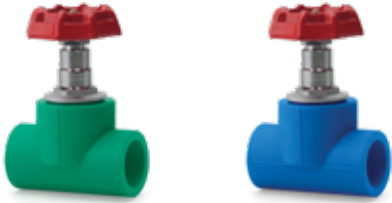

GATE VALVE

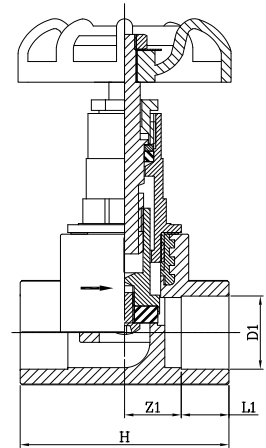

Size (mm)	ØD	L	L _T
20	19.50	14.50	61.00
25	24.50	16.00	70.00
32	31.50	18.00	85.00
40	39.50	20.50	95.00
50	49.50	23.50	114.00
63	62.50	27.50	133.50



BALL VALVE

(HOT & COLD WATER)

Size (mm)	ØD	L	H
20	19.50	73.04	62.24
25	24.50	77.60	74.26
32	31.50	87.64	86.42
40	39.45	103.72	98.36
50	49.45	123.92	116.86
63	62.50	149.36	139.10

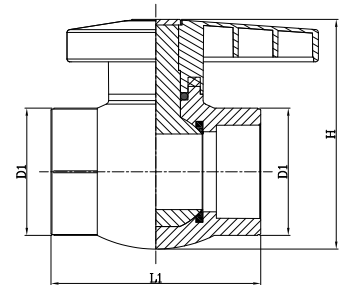

FLANGE

Size (mm)	ØD1	ØD2	ØD3	P.C.D	ØF	No. of Hole	T
32	43.00	54.00	117.00	80.00	17.00	04	21.00
40	51.50	60.50	130.00	89.00	17.00	04	21.50
50	63.50	73.50	143.50	98.00	17.50	04	22.40
63	80.50	90.00	159.00	121.00	17.50	04	25.60
75	93.50	106.50	175.00	140.00	17.50	04	27.50
90	113.00	126.00	198.50	152.00	17.50	08	30.50
110	134.20	147.00	220.00	190.00	17.50	08	31.50
160	187.00	209.50	289.00	241.00	19.05	08	36.50

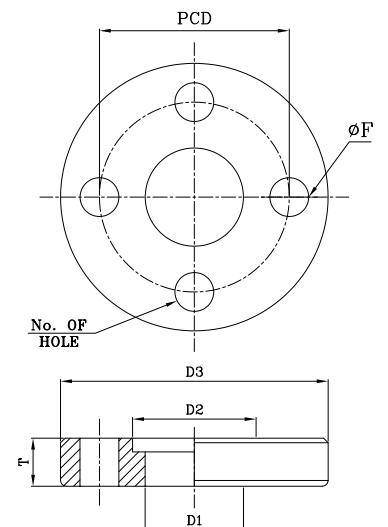

PP-R IS AN IDEAL MATERIAL FOR HOT & COLD WATER PLUMBING SYSTEMS



FLANGE WITH CORE

Size (mm)	ØD	ØD1	L	H	T
32	31.50	53.00	20.00	22.50	8.00
40	39.45	59.50	22.30	29.30	12.00
50	49.45	72.50	24.10	30.00	12.00
63	62.50	88.00	27.50	32.00	12.00
75	74.90	104.50	30.00	35.50	14.00
90	89.90	124.00	33.00	38.00	16.00
110	110.00	145.00	37.00	44.50	16.00
160	156.00	205.50	48.60	58.50	19.40

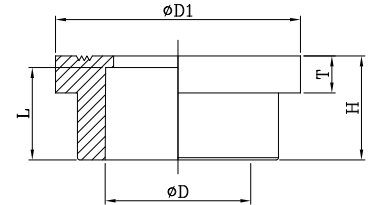

REDUCER

Size (mm)	ØD1	ØD2	L1	L2	H
25 X 20	24.50	19.50	16.00	14.50	34.50
32 X 25	31.50	24.50	18.00	16.00	38.00
32 X 20	31.50	19.50	18.00	14.50	36.50
40 X 32	39.45	31.50	20.50	18.00	42.50
40 X 25	39.45	24.50	20.50	16.00	40.50
40 X 20	39.45	19.50	20.50	14.50	39.00
50 X 40	49.45	39.45	23.50	20.50	48.00
50 X 32	49.45	31.50	23.50	18.00	45.50
50 X 25	49.45	24.50	23.50	16.00	43.50
50 X 20	49.45	19.50	23.50	14.50	42.00
63 X 50	62.50	49.45	27.50	23.50	59.00
63 X 40	62.50	39.45	27.50	20.50	56.00
63 X 32	62.50	31.50	27.50	18.00	54.50
63 X 25	62.50	24.50	27.50	16.00	51.50
63 X 20	62.50	19.50	27.50	14.50	51.50
75 X 63	74.90	62.50	30.00	27.50	57.50
75 X 50	74.90	49.45	30.00	23.50	53.50
75 X 40	74.90	39.50	30.00	20.50	50.50
75 X 32	74.90	31.50	30.00	18.00	48.00
90 X 75	74.90	24.50	33.00	31.50	64.50
90 X 63	89.90	74.50	33.00	20.50	53.50
90 X 50	89.90	62.50	33.00	23.50	56.50
110 X 90	89.90	49.50	37.00	33.00	70.00
110 X 75	89.90	39.50	37.00	31.50	68.50
110 X 63	110.90	89.90	37.00	30.00	67.00
160 X 110	159.50	109.00	48.00	37.00	85.00

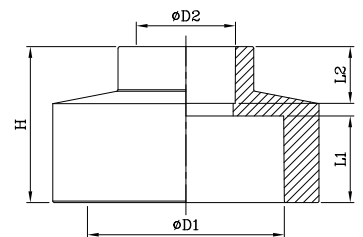

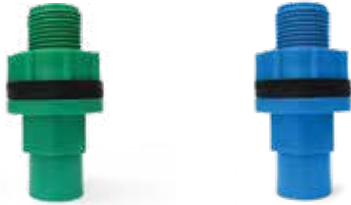

TANK CONNECTOR SHORT

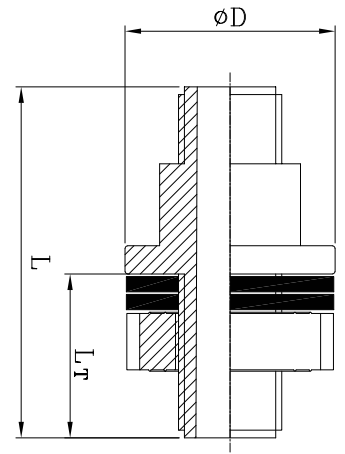

Size (mm)	ØD	L	L _r
25	25.00	74.50	35.70
32	32.00	84.50	40.00
40	40.00	91.04	44.00
50	50.00	99.70	48.40
63	63.00	102.00	49.50



TANK CONNECTOR

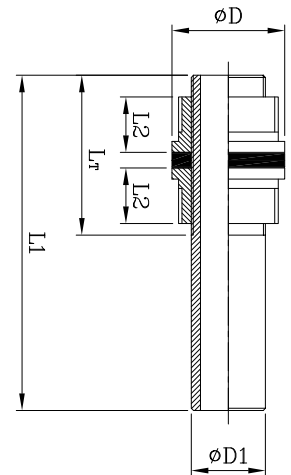

Size (mm)	ØD	L1	L _r	L2
20	20.00	140.00	66.00	20.00
25	25.00	146.00	72.00	22.00
32	32.00	150.00	76.00	25.00
40	40.00	166.00	91.00	29.00
50	50.00	180.00	105.00	35.00
63	63.00	198.00	123.00	42.00



STUB END

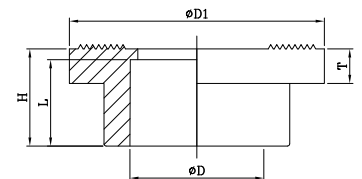

Size (mm)	ØD	ØD1	L	H	T
32	31.50	59.00	20.00	22.50	8.00
40	39.45	68.00	22.30	29.30	12.00
50	49.45	76.50	24.10	30.00	12.00
63	62.50	99.50	27.50	32.00	12.00
75	74.90	118.50	30.00	35.50	14.00
90	89.90	130.50	33.00	38.00	16.00
110	110.00	168.50	37.00	44.50	16.00
160	156.00	218.00	48.60	58.50	19.40

PP-R IS AN IDEAL MATERIAL FOR HOT & COLD WATER PLUMBING SYSTEMS



SADDLE

Size (mm)	ØD	ØD1	ØD2	L	H
63 X 32	31.50	21.50	48.00	21.50	43.00
75 X 32	31.50	21.50	48.00	21.50	42.00
90 X 32	31.50	21.50	48.00	21.50	42.00
110 X 32	31.50	21.50	48.00	21.50	42.00
160 X 32	31.50	21.50	48.00	21.50	42.00

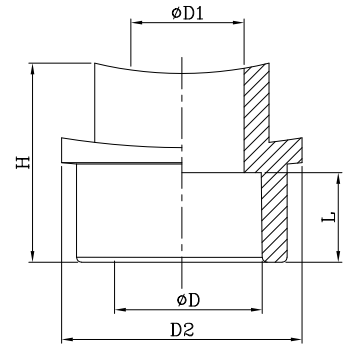

BRASS INSERT FITTINGS DIMENSIONS



MALE THREADED ADAPTOR

Size (mm)	ØD	Threads (inch)	L	L _T	H
20 X 20 (1/2")	19.50	1/2	14.50	15.00	54.50
25 X 25 (3/4")	24.50	3/4	16.00	17.00	58.00
32 X 32 (1")	31.50	1	18.00	19.00	62.00
40 X 40 (1 1/4")	39.45	1 1/4	20.50	22.00	72.00
50 X 50 (1 1/2")	49.45	1 1/2	23.50	22.00	75.00
63 X 63 (2")	62.50	2	27.50	26.30	88.30

Refer Figure - 1

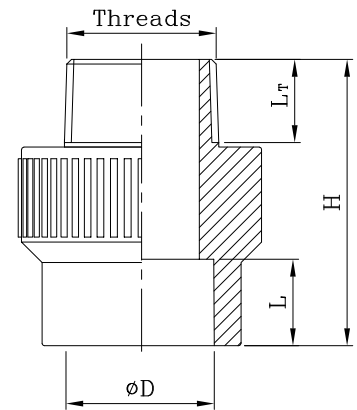

Figure - 1

REDUCING MALE THREADED ADAPTOR

Size (mm)	ØD	Threads (inch)	L	L _T	H
20 X 25 (3/4")	19.50	3/4	14.50	17.00	58.00
25 X 20 (1/2")	24.50	1/2	16.00	15.00	56.00
32 X 20 (1/2")	31.50	1/2	18.00	15.00	58.00
32 X 25 (3/4")	31.50	3/4	18.00	17.00	60.00
40 X 50 (1 1/2")	39.45	1 1/2	20.50	22.00	72.00

Refer Figure - 1

Size (mm)	ØD	Threads (inch)	L	L _T	H
40 X 32 (1")	39.50	1	20.50	19.00	66.50

Refer Figure - 2

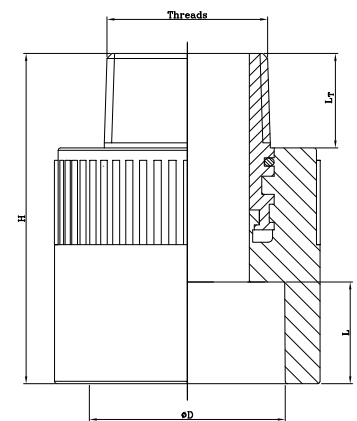
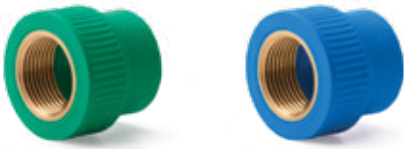

Figure - 2



FEMALE THREADED ADAPTOR

Size (mm)	ØD	Threads (inch)	L	L _T	H
20 X 20 (1/2")	19.50	1/2	14.50	15.00	39.50
25 X 25 (3/4")	24.50	3/4	16.00	16.30	41.00
32 X 32 (1")	31.50	1	18.00	19.00	43.00
40 X 40 (1 1/4")	39.50	1 1/4	20.50	25.00	50.00
50 X 50 (1 1/2")	49.45	1 1/2	23.50	21.40	53.00
63 X 63 (2")	62.50	2	27.50	25.70	62.00

Refer Figure - 1

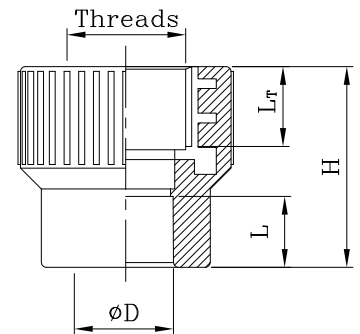

Figure - 1

REDUCING FEMALE THREADED ADAPTOR

Size (mm)	ØD	Threads (inch)	L	L _T	H
20 X 25 (3/4")	19.50	3/4	14.50	16.30	41.00
25 X 20 (1/2")	24.50	1/2	16.00	15.00	41.00
32 X 20 (1/2")	31.05	1/2	18.00	15.00	42.00
32 X 25 (3/4")	31.50	3/4	18.00	16.30	43.00

Refer Figure - 1

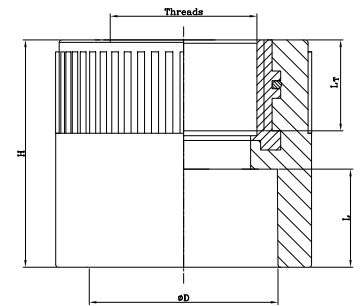

Figure - 2

Size (mm)	ØD	Threads (inch)	L	L _T	H
40 X 32 (1")	39.50	1	20.50	19.00	47.50

Refer Figure - 2



MALE THREADED ELBOW

Size (mm)	ØD	Threads (inch)	L	L _T
20 X 20 (1/2")	19.50	1/2	14.50	15.00
25 X 25 (3/4")	24.50	3/4	16.00	17.00
32 X 32 (1")	31.50	1	18.00	19.00
40 X 40 (1 1/4")	39.45	1 1/4	20.50	22.00

REDUCING MALE THREADED ELBOW

Size (mm)	ØD	Threads (inch)	L	L _T
20 X 25 (3/4")	19.50	3/4	14.50	17.00
25 X 20 (1/2")	24.50	1/2	16.00	15.00
32 X 20 (1/2")	31.50	1/2	18.00	15.00
32 X 25 (3/4")	31.50	3/4	76.60	17.00

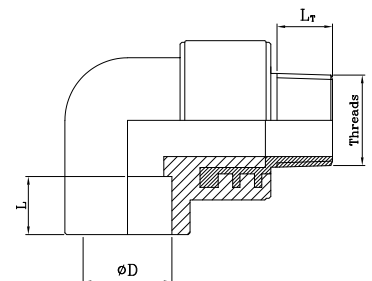

PP-R IS AN IDEAL MATERIAL FOR HOT & COLD WATER PLUMBING SYSTEMS



FEMALE THREADED ELBOW

Size (mm)	ØD	Threads (inch)	L	LT
20 X 20 (1/2")	19.50	1/2	14.50	15.00
25 X 25 (3/4")	24.50	3/4	16.00	16.30
32 X 32 (1")	31.50	1	18.00	19.00
40 X 40 (1 1/4")	39.45	1 1/4	20.50	21.40

REDUCING FEMALE THREADED ELBOW

Size (mm)	ØD	Threads (inch)	L	LT
20 X 25 (3/4")	19.50	3/4	14.50	16.00
25 X 20 (1/2")	24.50	1/2	16.00	15.00
32 X 20 (1/2")	31.50	1/2	18.00	15.00
32 X 25 (3/4")	31.50	3/4	59.60	16.00

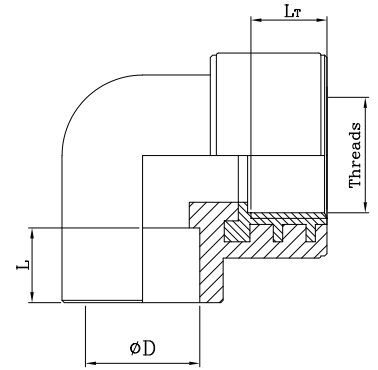

FEMALE THREADED ELBOW WITH SUPPORT

Size (mm)	ØD	Threads (inch)	L	LT	X1	X2	Ø
20 X 20 (1/2")	19.50	1/2	14.50	15.00	60.00	50.00	5.00

REDUCING FEMALE THREADED ELBOW WITH SUPPORT

Size (mm)	ØD	Threads (inch)	L	LT	X1	X2	Ø
25 X 20 (1/2")	24.50	1/2	16.00	15.00	64.00	54.00	5.00
25 X 25 (3/4")	24.50	3/4	16.00	16.30	64.00	54.00	5.00

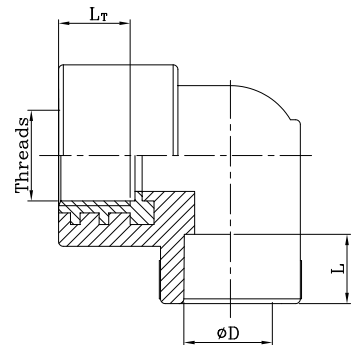
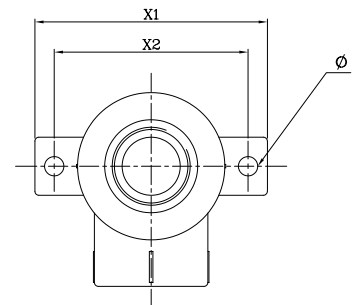



MALE THREADED TEE

Size (mm)	ØD	Threads (inch)	L	L _T	H
20 X 20 (1/2")	19.50	1/2	14.50	15.00	51.00
25 X 25 (3/4")	24.50	3/4	16.00	17.00	59.00
32 X 32 (1")	31.50	1	18.00	19.00	70.00

REDUCING MALE THREADED TEE

Size (mm)	ØD	Threads (inch)	L	L _T	H
25 X 20 (1/2")	24.50	1/2	16.00	15.00	59.00
32 X 20 (1/2")	31.50	1/2	18.00	15.00	70.00
32 X 25 (3/4")	31.50	3/4	18.00	17.00	70.00

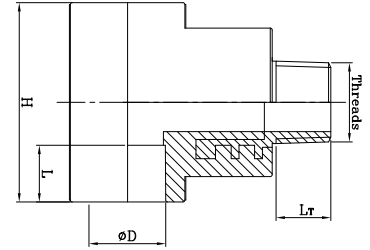

FEMALE THREADED TEE

Size (mm)	ØD	Threads (inch)	L	L _T	H
20 X 20 (1/2")	19.50	1/2	14.50	15.00	51.00
25 X 25 (3/4")	24.50	3/4	16.00	16.30	59.00
32 X 32 (1")	31.50	1	18.00	19.00	70.00

REDUCING FEMALE THREADED TEE

Size (mm)	ØD	Threads (inch)	L	L _T	H
25 X 20 (1/2")	24.50	1/2	16.00	15.00	59.00
32 X 20 (1/2")	31.50	1/2	18.00	15.00	70.00
32 X 25 (3/4")	31.50	3/4	18.00	16.30	70.00

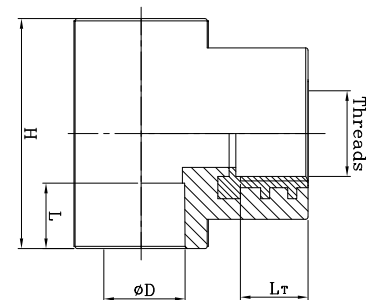

MALE THREADED UNION

Size (mm)	ØD	Threads (inch)	L
20 X 20 (1/2")	19.50	1/2"	14.50
25 X 25 (3/4")	24.50	3/4"	16.00
32 X 32 (1")	31.50	1"	18.00
40 X 40 (1 1/4")	39.50	1 1/4"	20.50
50 X 50 (1 1/2")	49.50	1 1/2"	23.50
63 X 63 (2")	62.50	2"	27.50

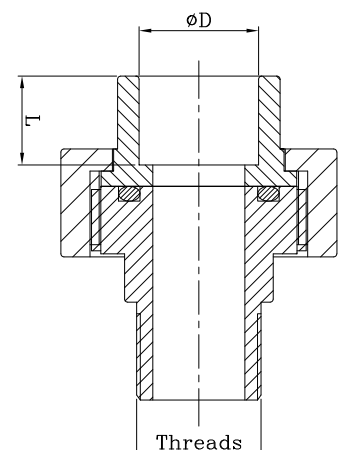

PP-R IS AN IDEAL MATERIAL FOR HOT & COLD WATER PLUMBING SYSTEMS



FEMALE THREADED UNION

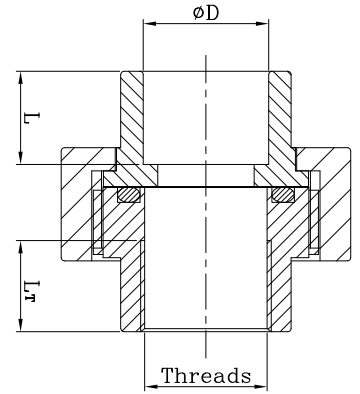

Size (mm)	ØD	Threads (inch)	L	L _T
20 X 20 (1/2")	19.50	1/2"	14.50	15.00
25 X 25 (3/4")	24.50	3/4"	16.00	16.30
32 X 32 (1")	31.50	1"	18.00	19.00
40 X 40 (1 1/4")	39.45	1 1/4"	20.50	21.40
50 X 50 (1 1/2")	49.45	1 1/2"	23.50	21.40
63 X 63 (2")	62.50	2"	27.50	25.70

WALL MIXER



HOT DOWN & COLD DOWN

25mm (3/4") X 20mm (1/2")

Size (mm)	Size (inch)
160	6

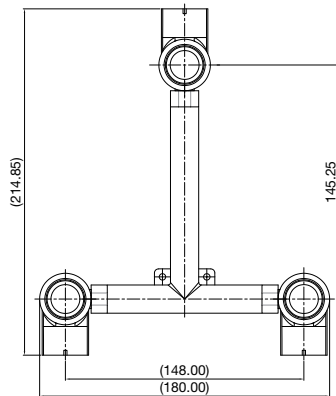

HOT UP & COLD UP

25mm (3/4") X 20mm (1/2")

Size (mm)	Size (inch)
160	6

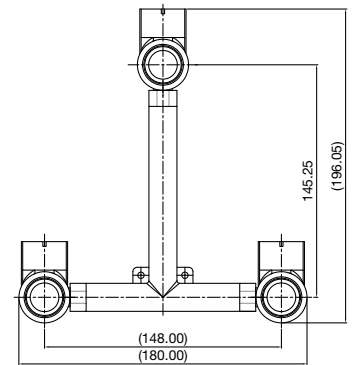

HOT SIDE & COLD SIDE

25mm (3/4") X 20mm (1/2")

Size (mm)	Size (inch)
160	6

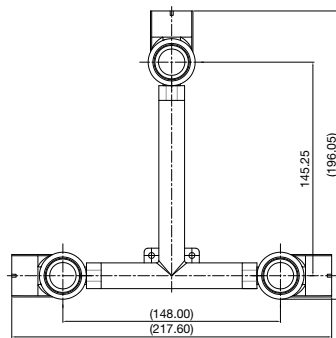

HOT SIDE & COLD DOWN

25mm (3/4") X 20mm (1/2")

Size (mm)	Size (inch)
160	6





HOT DOWN & COLD SIDE

25mm (3/4") X 20mm (1/2")

Size (mm)	Size (inch)
160	6

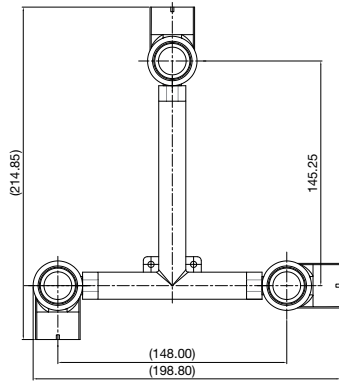

HOT UP & COLD DOWN

25mm (3/4") X 20mm (1/2")

Size (mm)	Size (inch)
160	6

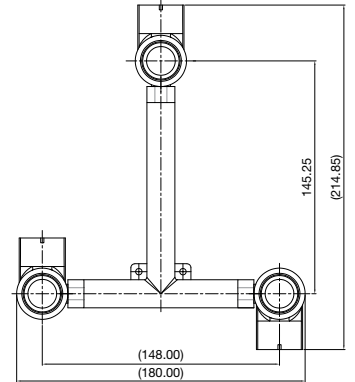

HOT DOWN & COLD UP

25mm (3/4") X 20mm (1/2")

Size (mm)	Size (inch)
160	6

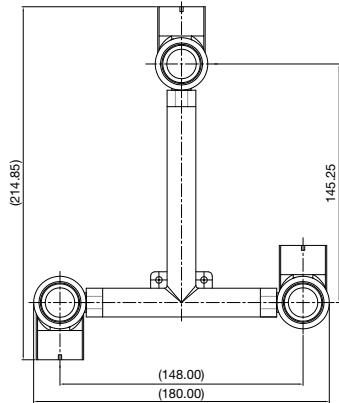

ACCESSORIES



DIE SET

Size (mm)
20
25
32
40
50
63



CUTTER

Size (mm)
20 - 40
50 - 90
75 - 110
160

WELDING DEVICE



Size (mm)
20 - 63
75 - 110

REPAIR SECTION



Size (mm)
7 X 11

REPAIR BAR



Size (mm)
7 X 11

LARGE DIAMETER WELDING DEVICE



Size (mm)
75 - 160
160

PP-R IS AN IDEAL MATERIAL FOR HOT & COLD WATER PLUMBING SYSTEMS

QUALITY ASSURANCE TESTS

PIPES QUALITY TEST

ACCEPTANCE TEST
Visual Appearance
Colour
Dimensions
Internal Long term Hydrostatic Pressure Test
Heat Reversion
Charpy Impact Strength
Density
Melt Flow Rate
Carbon black content & dispersion (black pipes)

TYPE TEST
Opacity
Fusion Compatibility
Thermal Stability by hydrostatic pressure test
Influence on water intended for human consumption
UV Test (Effect on sunlight for black, 3 layer & thermex pipes)
Water hammer test
Hot & cold water test

FITTING QUALITY TEST

ACCEPTANCE TEST
Visual Appearance
Colour
Dimensions
Wrenching test (insert & threaded items)
Hammer Test
Internal Hydrostatic pressure test
Leakage test (insert items, extended end plug & tank connector)

TYPE TEST
Water hammer test
Hot & cold water test
Long term Hydrostatic Pressure test

BALL VALVE QUALITY TEST

ACCEPTANCE TEST
Visual Appearance
Colour
Dimensions
Internal Hydrostatic pressure test
Drip proofness test
Torque wrench test
Tumbler test

TYPE TEST
Endurance test
Long term Hydrostatic Pressure test

TECHNICAL DETAILS

THERMAL EXPANSION

A pipe line which is subjected to a variation of temperatures changes its length if it is free to do so, This change in length is proportional to the linear coefficient of thermal expansion of the material of pipeline. The linear expansion or contraction caused by the change in ambient temperature gradient can easily be calculated using the following formula.

$$\Delta L = \sigma \times L \times \Delta T$$

WHERE :

- ΔL = Expansion(+) or contraction(-) in length,(mm)
- L = Initial pipe length, (Meter)
- σ = Coefficient of thermal expansion (for PP-R = 0.15 mm/m°C)
- ΔT = Change in temperature (°C)

EXAMPLE: for 5 meter PP-R line operating between 25 to 55°C
 $\Delta T = (55-25)=30^{\circ}\text{C}$
 $\Delta L = 0.15 \times 5 \times 30 = 22.5 \text{ mm}$

The expansion and contraction adjustment of GREENFIT PP-R pipeline is generally made in longitudinal direction only. Enough space shall be provided and proper type of supports shall be used to allow the free movement of pipe in axial directions.

Once the change in length of pipeline on account of thermal expansion/contraction has been calculated, a correct planning of pipelines is necessary to ensure that its effect do not cause deformation of the piping itself. GREENFIT PP-R systems make it possible to easy and convenient compensation for change in length using the suitable provision of following:

- Fixed & Sliding supports.
- Free flexible pipe segment (Expansion Arm).
- Free flexible pipe loop (Compensation Loop).

FREE AND SLIDING SUPPORTS

Fixed and Sliding supports secure external pipelines to the masonry structure of the building, to prevent the movements generated by thermal expansion, totally or partially.

Fixed Supports: - These are used when the axial expansion of the pipeline should be limited. Fixed support provides a rigid connection between external pipeline installations with masonry structure. The fixed supports must normally be positioned where the system changes direction (Elbows, Tees, etc.) & near to Valves, Cocks, Water meter, etc. to ensure that expansion forces are not induced these points. In all cases, fixed support should always be provided next to any joint in the pipeline created using any welded fitting. Obviously the fixed supports limit the length of section of pipe free to expand, and reduce the relative change in length value.

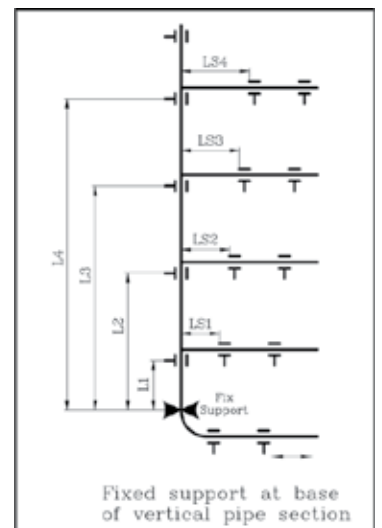
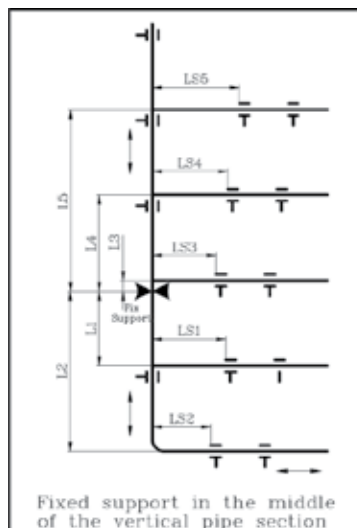
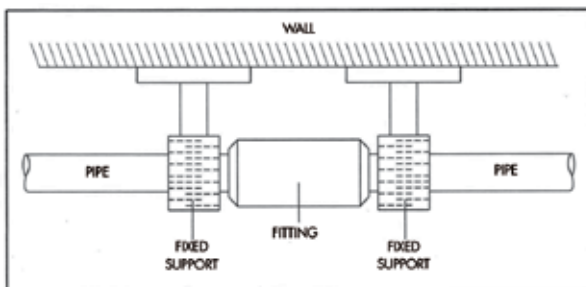

Sliding Supports: - are used to allow the pipe to move axially in both directions. They have to be positioned well away from joints made using welded fittings, on a free length of the pipes surface. The sliding support collar must be absolutely free from pipe diameter otherwise it may damage the surface of the pipe where it is installed. Sliding support also ensures that the pipeline remain straight in spite of thermal stresses.

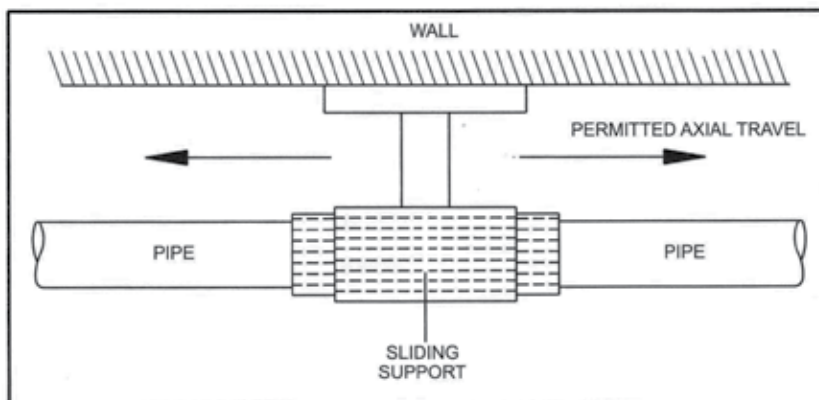

Support Spacing: - For horizontal and vertical external pipeline installation on wall, the recommended distances between supports are given in following tables for various pipe sizes.

Size (mm)	Horizontal clamp spacing distance according to temperatures, cm						
	20°C	30°C	40°C	50°C	60°C	70°C	80°C
20	65	63	61	60	58	53	48
25	75	74	70	69	66	61	56
32	90	88	86	83	80	75	70
40	110	110	105	100	95	90	85
50	125	120	115	110	105	100	90
63	140	135	130	125	120	115	105
75	155	150	145	135	130	125	115
90	165	160	155	145	140	130	120
110	175	175	170	165	155	145	135

Size (mm)	Horizontal clamp spacing distance according to temperatures, cm						
	20°C	30°C	40°C	50°C	60°C	70°C	80°C
20	85	82	79	78	75	69	62
25	98	96	91	88	86	79	73
32	117	114	112	108	104	98	91
40	143	143	137	130	124	117	111
50	163	156	150	143	137	130	117
63	182	176	169	163	156	150	137
75	202	195	189	176	169	163	150
90	215	208	202	189	182	169	156
110	228	228	221	215	202	189	176

FREE FLEXIBLE PIPE SEGMENT (EXPANSION ARM)

With the help of free flexible pipe segment, provided at the position of change in direction, the change in length of pipeline is totally compensated. The length of free flexible pipe segment is calculated using following formula:

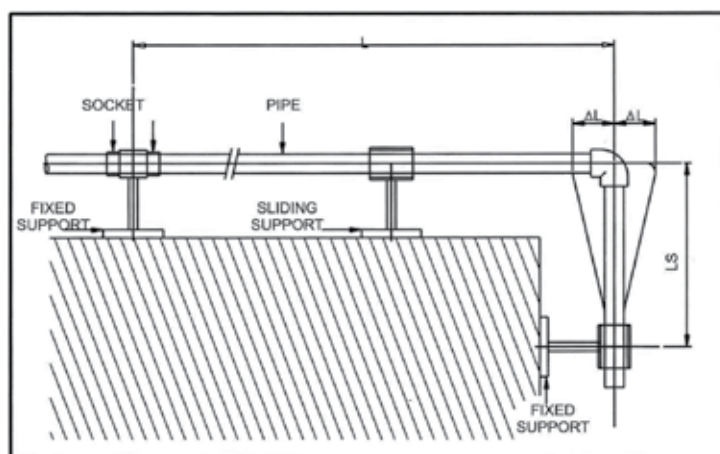

$LS = C \cdot \Delta L \cdot d$ where
 LS = Length of free flexible segment (mm).
 C = Constant of material (for PP-R, $C= 30$).
 d = Pipe outside diameter (mm).
 ΔL = Expansion or contraction length (mm).

FREE FLEXIBLE PIPE LOOP (COMPENSATION LOOP)

If the change in length cannot be compensated using expansion arm, it is necessary to install a free flexible loop (Compensation loop). Free flexible bend can be easily prepared on site with required lengths of GREENFIT PP-R pipe & 4 nos. of 90° elbows.

To prepare a free flexible loop you have to calculate:

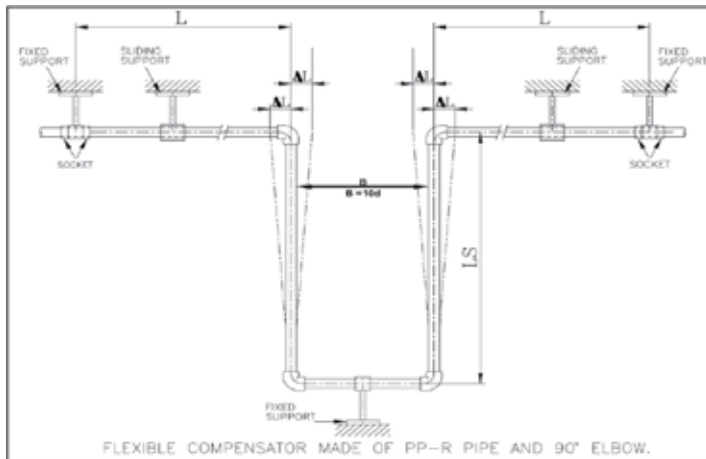

- The length of free flexible segment (LS) with the help of formula as explained in Free flexible pipe segment (Expansion Arm)
- The minimum width (B) between two arms of the loop = 10 times the outside diameter of the pipe.

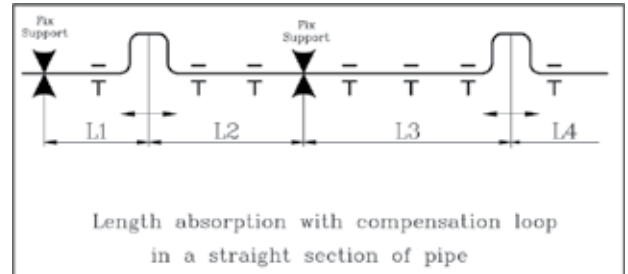

LAYING IN SANITARY SHAFT / PIPE DUCT OF A BUILDING

No.	Recommendation For Pipe Connection	Description
1		Pipe connection can be made At some distance away from The wall
2		The connecting pipe can be Passed through a hole much Larger than the pipe diameter
3		The connection can Be made through a Branch pipe to provide flexibility

When making the apartment pipe connections from main pipe going through the sanitary shaft of the building, the alternative techniques shown above can be applied in order to compensate for thermal expansion & contraction.

BENDING

During laying of pipeline, GREENFIT PP-R pipes may be required to be bent. Bending shall be done by using hot air blowing at 140°C. Direct heating by open flame shall be avoided, Radius for GREENFIT PP-R pipe bend should be minimum 8 times its diameter. The table given besides indicate minimum bending radius for each sized of pipe.

Drawing	Pipe diameter (mm)	Minimum bending radius (mm)
	20	160
	25	200
	32	256
	40	320
	50	400

PP-R IS AN IDEAL MATERIAL FOR HOT & COLD WATER PLUMBING SYSTEMS

INSULATION FOR LOWER TEMPERATURE

FOR HOT WATER

When conveying hot water through any pipe, heat is transferred through the pipe wall. PRINCE pipes have a much lower GREENFIT PP-R coefficient of thermal conductivity (0.24 W / mK) compared to metal pipes. Therefore, normally it may not be required to insulate the pipelines which is used for hot water concealed application. However, for centralised heating systems, to prevent heat loss and isolate the pipelines from other utilities, it is advisable to insulate these lines. The required thickness of insulation is quite lower as compared with conventional lines. Given besides are the recommended insulation thickness for different pipe size.

Pipe Size (mm)	Thermal conductivity of insulation material	
	0.030 W /m.K	0.030 W /m.K
	Recommended minimum insulation thickness in mm	
20	6	10
25	6	10
32	10	13
40	10	13
50	10	13
63	13	20
75	20	20
90	20	25
110	25	32

FOR COLD WATER

Potable cold water plants have to be protected against heat gain and the formation of condensation. Standard value for the minimum thickness of insulation as stipulated in DIN-1988, part 2 have to be taken from the following table :

Minimum insulation thickness for the insulation of potable water pipes (10°C) as per DIN 1988, part 2	
Type of installation	Insulation thickness (for 0.04 W/m.K thermal conductivity material) in mm
Open installed pipes, in non heated room (i.e. cellar)	4mm
Open installed pipe in heated room	9mm
Pipe in a duct, without warm pipe	4mm
Pipe in a duct beside warm pipe	13mm
Pipe in a pipe chase riser	4mm
Pipe in a pipe chase, beside warm water pipes	13mm
Pipe on concrete floor	4mm

RESISTANCE TO ULTRA VIOLET (UV) RAYS

PRINCE monolayer pipes & fittings are have sufficient U.V. stability in order to protect them GREENFIT PP-R from UV rays during storage in open area for a period of about 6 months. However, it is not advisable to use these pipes and fittings under direct sunlight continuously. For outdoor installation on pipelines, PRINCE Piping Systems offers 3 layers GREENFIT PP-R pipes, which are resistant to U.V. rays.

SUITABILITY FOR DRINKING WATER

PRINCE pipes & fittings meet the requirements of IS 10500-91 for drinking water and GREENFIT PP-R IS 10146-87 for leachable additives as its safe use for drinking water.

FIRE RESISTANCE

PRINCE pipes & fittings have combustion point 330°C & burning point 360°C. These conform GREENFIT PP-R with B2 class fire requirements of normal combustibility according to DIN 4102. On fire, PP-R pipes & fittings emit carbon dioxide and water. Other than this, carbon monoxide gas, molecular hydrocarbon and oxidation products of these are also emitted in proportion to the availability of oxygen. Even if the fire is incomplete, the materials emitted are less poisonous than wood or similar materials on fire under the same conditions. The smoke that comes out of GREENFIT PP-R fire does not cause rusting.

LOW TEMPERATURE RESISTANCE

At lower temperature of 0° C and below, the flexibility of pipes reduces and impact strength GREENFIT PP-R also reduces. This makes pipes more prone to mechanical damages against impact loads. To avoid the damages at low temperature, it is advisable to insulate the pipe lines.

DESIGN GUIDELINES

GENERAL GUIDELINES

While designing the GREENFIT PP-R piping system, one should be aware that GREENFIT PP-R piping is quite different than other traditional materials like GI or Copper as well as PVC or CPVC. For good and safe design an installation, the following shall be taken into account.

- Pipes & fittings have different dimensions from other types of pipes and fittings. Even though the bore diameter of pipe is less than the equivalent metal or plastic pipe, the flow is more due to smoothness & less friction. Hydraulic calculation should be done each time for the best choice of pipeline diameters.
- Linear thermal expansion/contraction of GREENFIT PP-R pipes is more as compared with metal pipes. This needs to be taken care during designing and installation to avoid stressing of pipeline by providing flexible free length and proper supporting. (Refer page no. 28 - Thermal expansion)
- STANDARD WORKING CONDITION AND SERVICE LIFE for designing (Refer page no. 7)
- Use 3 layer pipes for outdoor installations.
- Use Black pipes for solar heating system.
- Provide insulation for centralized heating systems and chilled water systems. (Refer page no.31- Insulation)
- Dos & Don'ts (Refer page no. 35 to 36)

PIPELINE DESIGN

FLOW RATE

Analytical flow is typical for each analytical section. Draw-off point's water quantity shall be worked out, taking into consideration water consumption (which is not simultaneous at all draw-offs). Following table gives formula for calculating the analytical flow for the different types of application :

Application	Design flow rate Q, in lps as per DIN 1988 part 3 can be calculated from following formula	
	formula for $0.07 < \Sigma q < 20$ lps	formula for $\Sigma q > 20$ lps
Residential buildings	$Q = 0.682 (\Sigma q)^{0.45} - 0.14$	$Q = 1.7 (\Sigma q)^{0.21} - 0.7$
Commercial buildings	$Q = 0.682 (\Sigma q)^{0.45} - 0.14$	$Q = 1.4 (\Sigma q)^{0.54} - 0.48$
Hotels & Shopping Malls	$Q = 0.4 (\Sigma q)^{0.366}$ $Q = 0.698 (\Sigma q)^{0.5} - 0.12$	$Q = 1.08 (\Sigma q)^{0.5} - 1.82$ $Q = 1.08 (\Sigma q)^{0.5} - 0.12$
Hospitals	$Q = 0.698 (\Sigma q)^{0.5} - 0.12$	$Q = 0.25 (\Sigma q)^{0.65} - 1.25$
Schools	$Q = 4.4 (\Sigma q)^{0.27} - 3.41$	$Q = 22.5 (\Sigma q)^{0.5} - 11.5$

WHERE: Q = Standard outflow from the draw-off points, lps

Σq = Sum of all standard outflows from the draw-off points serviced by dimensional section of the installation, lps

DESIGN FLOW RATES OF COMMON WATER POINTS

Minimum Pressure	Type of water point	Calculated Flow on Taking	
		Mixed water Cold / Warm	Only Cold or Warm Potable Water
Bar	Designation	lps	lps
0.5	Taps Without air inlet DN 15	-	0.30
0.5	Taps Without air inlet DN 20	-	0.50
0.5	Taps Without air inlet DN 25	-	1.00
1.0	Taps With air inlet DN 10	-	0.15
1.0	Taps With air inlet DN 15	-	0.15
1.0	Shower heads for purification showers DN15	0.10	0.20
1.2	Flush Valves DN 15 (Toilet)	-	0.70
0.4	F.V. DN 25 (Toilet)	-	1.00
1.0	Flush Valves DN 15 (Urinal)	-	0.30
1.0	Domestic dish washers DN 15	-	0.15
1.0	Domestic washing machine DN 15	-	0.25

DESIGN FLOW RATES OF COMMON WATER POINTS

Minimum Pressure	Type of water point	Calculated Flow on Taking	
		Mixed Water Cold/Warm	Only Cold or Warm Potable Water
Bar	Designation	lps	lps
	Mixing battery for :		
1.0	Shower-bathes DN15	0.15	-
1.0	Bath-tubs DN15	0.15	-
1.0	Kitchen sinks DN 15	0.07	-
1.0	Washstands DN 15	0.07	-
1.0	Bidet DN 15	0.07	-
1.0	Mixing battery DN20	0.30	-
0.5	Geyser DN 30	-	0.15
1.0	Geyser DN 20	-	0.20

PRESSURE LOSS

In normal piping, two types of pressure loss can be found,

1. Distributed pressure loss related to pipe roughness, dimensions, physical properties and velocity of the liquids.
2. Local loss related to elbows, tees, valves and fittings which cause a remarkable variation in the liquid flow.

1. DISTRIBUTED PRESSURE LOSS

The GREENFIT PP-R pipe has extremely smooth inner surfaces compared to metal pipes. Therefore, pressure loss is quiet low.

2. LOCAL PRESSURE LOSS

In pipeline, local pressure loss takes place due to presence of fittings which can be calculated using following formula

$$R = \frac{(r) V^2 \sigma}{2g}$$

WHERE: R = Total local pressure loss in (mm)
 r = Local resistance coefficient value as given in following table
 V = Mean velocity of fluid in (m/s)
 g = Acceleration of gravity = 9.81 (m/s²)
 σ = Specific gravity of water = 1000 (kg/m³)

Local resistance coefficient "r" for PRINCE GREENFIT PP-R plumbing fittings.

Note:

1. These are reference values and they vary according to water temperature.
2. As fitting diameter increases, the value of 'r' decreases.

Name of PP-R Fitting	Symbol for PP-R Fitting	Coefficient Value (r)
Coupler		0.25
Reducer: Single stage reducer Double stage reducer Three stage reducer Four stage reducer		0.50 0.60 0.70 0.85
Elbow 90° Elbow 45°		1.2 0.5
Tee		1.8
Male / Female Threaded Tee		1.8
Reducing Tee		3.0
Male / Female Threaded Adaptor Reducing Male / Female Adaptor		0.5 0.8
Male / Female Threaded adaptor Reducing Threaded Elbow adaptor		1.4 1.6
Valve 20 25 32		9.5 8.5 7.6
Union		8.3

JOINTING METHODS

PROCESS: Fusion Welding

CUTTING

- Cut the pipe at a right angle to its axis using burr-free cutter.
- Ensure that the pipe is free from burrs or cutting chips.
- Clean the pipe & fitting perfectly before welding.
- Mark welding depth at the end of pipe.



HEATING

- Mount the suitable dyes on the heating element of the welding machine according to the diameter of pipe and fitting.
- Connect the welding machine to 220 volts A.C. power supply.
- Select 260°C temperature on the welding machine thermostat.
- Wait until the required working temperature is reached.
- Insert the pipe and the fitting in the dyes by exerting light pressure.



WELDING

- After heating, quickly insert the pipe into the fitting by exerting light pressure.
- Any misalignment should be corrected immediately after insertion to avoid any stress in the weld.
- Allow the joint to cool as per the cooling time given in table.

DON'Ts



CUTTING

Do not cut slant/unevenly.



DEBURRING AND RIDGE REMOVAL

Do not proceed with installation of pipe without deburring as the burr when heated will create an extra blockage inside the pipe.



CLEANING & MARKING

Do not proceed without cleaning as it will create problems during welding due to the presence of dirt or mud.

WELDING JOINT

- Do not set the temperature of the heater higher or lower than 260°C
- Do not initiate the jointing process without gloves.
- Misalignment of jointing to be corrected immediately before cooling, so as to avoid stress in the weld.



DOs



STORAGE

Although Greenfit PP-R Pipe system material is stabilized for use at elevated temperatures do not expose the pipes & fittings to direct sunlight.

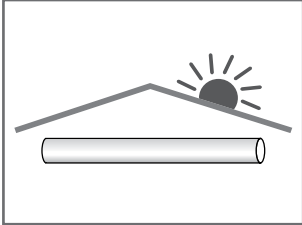

TRANSPORTATION

During transportation, Greenfit PP-R pipes should be loaded in a proper manner, otherwise pipes may get deformed.

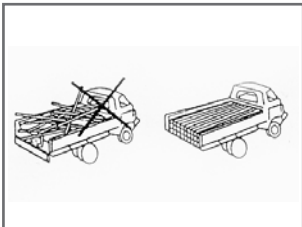

PREPARATION FOR WELDING

Before welding/jointing, clean the surface of Greenfit PP-R Pipes & Fittings with a clean piece of cloth and then start welding.

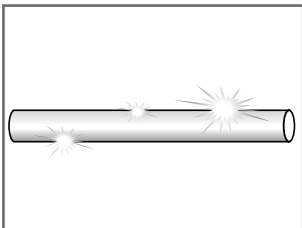

WELDING

Avoid air draughts during welding to avoid stress in the welds.



DON'Ts



STORAGE

Greenfit PP-R Pipe storage height should not be more than 1.5 meter.

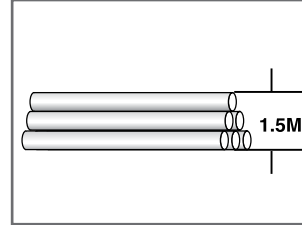

HANDLING

The Greenfit PP-R Pipe system should be protected from impact of hard and sharp objects.



HEATING

While welding of Greenfit PP-R Pipes and fittings check that the thermostat of welding machine and dyes have reached correct temperature (260°C). While welding, the pipe must not be twisted.



SAFE WELDING

Welding machines shall be earthed properly during use.

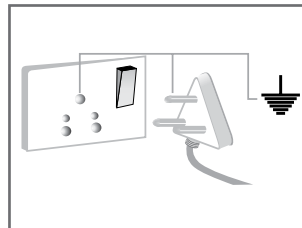

DOs



SAFE WELDING

Do not cool welding machine in water.

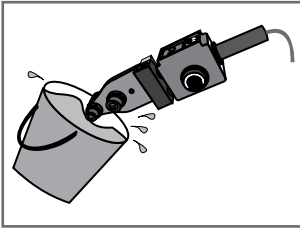

DON'Ts



THREAD JOINT

Do not over tighten threaded fittings & valves.



BENDING

Do not apply direct flame to fabricate bends or crossover pipes, as the direct exposure to fire may cause damage to the Greenfit PP-R pipes. Use only hot air blowing equipment at 140°C. (Cross overs are readily available.)

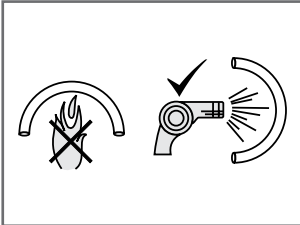

BENDING

While bending the pipe, the bending radius shall be more than 8 times the diameter of the pipe.

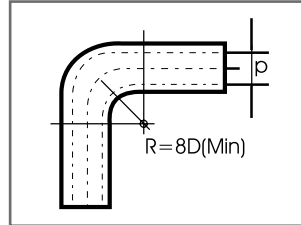

INSTALLATION AT LOWER TEMPERATURE

At sub zero temperatures (0°C & below) Greenfit PP-R Pipe system tends to break under impact. Therefore, installation at low temperatures should be done with care, and the pipe lines shall be insulated.

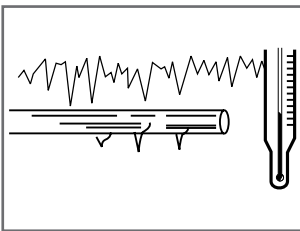

OUTDOOR INSTALLATION

Use 3 layered pipes for outdoor application.

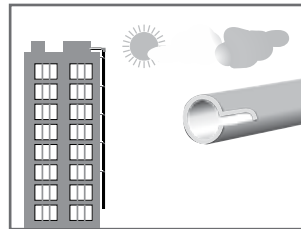

RECOMMENDED TIME FOR PP-R FUSION JOINTS

Pipe Dia (mm)	Welding Depth (mm)	Heating Time (Sec)	Welding Time (Sec)	Cooling Time (Sec)
20	14.50	6	4	2
25	16.00	7	4	2
32	18.00	8	6	4
40	20.50	12	6	4
50	23.50	18	6	4
63	27.50	24	8	6
75	30.00	30	8	6
90	33.00	40	8	6
110	37.00	50	10	8
160	55.00	60	15	10

HOLE REPAIRING

In case of accidental hole formation in pipe line due to drilling or piercing of pointed object, the pipe line can be repaired as follows :

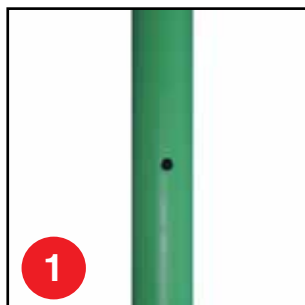

1

Accidental hole formation in pipe line.



2

Simultaneously heat the hole section in the pipe line and repair bar using repair section die and welding device for about 5 to 7 seconds depending upon the pipe thickness.

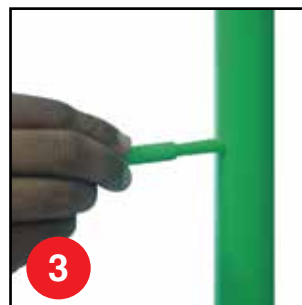

3

Insert heated repair bar in the hole up till the full depth and hold it for a minute.

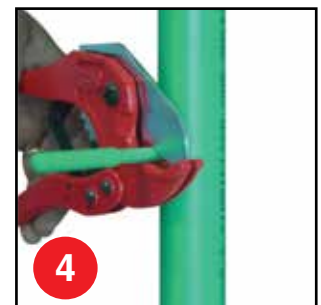

4

After cooling, cut the repair bar projected outside the pipe line using pipe cutter.

TESTING THE INSTALLATION

PRESSURE TEST

According to DIN 1988 GREENFIT PP-R Pipeline for potable water installation have to be (before concealing) hydraulically pressure tested as described under While carrying out the pressure test the material properties of GREENFIT PP-R pipes lead to expansion of pipe.

This influences the test result. A further influence of the result can be caused by the thermal expansion of GREENFIT PP-R pipes. Different temperatures of pipe & test medium lead to alteration of pressure. (A temperature change of 10°C corresponds to pressure difference of 0.5 to 1 bar). Therefore, the highest possible constant temperature of the test medium has to be ascertained at the hydraulic pressure test of installations with GREENFIT PP-R pipes.

PRIMARY TEST	MAIN TEST
For primary test, a pressure of 1.5 times of rated pressure shall be applied for a duration of 30 minutes. During this test, pressure drop shall be < 0.6 bar. If the pressure drops is > 0.6 bar, check the pipeline for leakage & retest.	After completion of primary test, main test must be conducted, which has to be effected with a test pressure of alternate 1 bar & 10 bar for every 5 minutes interval for 2 hours.

CHEMICAL RESISTANCE CHART

Chemical	PVC			CPVC					PPR					HDPE		
Temp in °C	20	40	60	20	40	60	80	100	20	40	60	80	100	20	40	60
Temp in °F	68	104	140	68	104	140	176	212	68	104	140	176	212	68	104	140
A																
Acetaldehyde	N	N	N	N	N	N	N	N	N	N	-	-	-	-	-	-
Aqueous, 40%	C	N	-	-	-	-	-	-	R	R	R	C	N	-	-	-
Acetamide	R	-	-	R	-	-	-	-	R	-	-	-	-	R	-	-
Acetic Acid, 10%	R	R	C	R	R	R	R	R	R	R	R	R	R	R	-	-
Acetic Acid, 20%	R	R	C	R	R	R	R	R	R	R	R	R	R	R	-	-
Acetic Acid, 25%	R	R	C	R	R	R	R	R	R	R	R	R	R	R	-	-
Acetic Acid, 30%	R	C	C	R	-	C	-	-	R	R	R	R	R	R	-	-
Acetic Acid, 60%	R	C	C	R	-	C	-	-	R	R	R	R	C	R	-	-
Acetic Acid, 80%	R	C	C	R	-	-	-	C	R	N	N	N	N	R	-	-
Acetic Acid, 85%	R	-	-	N	-	-	-	-	R	-	-	-	-	R	-	-
Acetic Acid Glacial, 100%	C	N	N	C	N	N	N	N	R	C	C	-	N	R	-	-
Acetic Acid, Hot	-	-	-	-	-	-	-	-	-	-	-	-	-	-	-	-
Acetic Acid, Vapor	R	-	-	R	-	-	-	-	R	-	-	-	-	R	-	-
Acetic Anhydride	N	-	-	-	-	-	-	-	R	C	C	-	N	R	-	-
Acetone	N	-	-	N	-	-	-	-	R	R	R	-	-	-	-	-
Acetone 5%	N	-	-	N	-	-	-	-	R	R	R	-	-	-	-	-
Acetone, pure	N	N	N	N	N	N	N	N	C	C	C	-	-	-	-	-
Acetone, up to 5%	-	-	-	R	-	-	-	-	-	-	-	-	-	-	-	-
Acetonitrile	-	-	-	-	-	-	-	-	R	-	-	-	-	-	-	-
Acetopheneditin	-	-	-	-	-	-	-	-	-	-	-	-	-	R	-	-
Acetophenone	-	-	-	-	-	-	-	-	R	-	N	-	-	R	-	-
Acetyl Acetone	N	-	-	N	-	-	-	-	-	-	-	-	-	-	-	-
Acetyl Bromide	-	-	-	-	-	-	-	-	-	-	-	-	-	-	-	-
Acetyl Chloride	N	-	-	N	-	-	-	-	R	-	-	-	-	-	-	-
Acetyl Nitrite	N	-	-	N	-	-	-	-	-	-	-	-	-	-	-	-
Acetyl-d I-Alanine	-	-	-	-	-	-	-	-	-	-	-	-	-	R	-	-
Acetyl-d 1-Lencine-n	-	-	-	-	-	-	-	-	-	-	-	-	-	R	-	-
Acetyl-d I-Meth ionine-n	-	-	-	-	-	-	-	-	-	-	-	-	-	R	-	-
Acetyl-d 1-Tryptophan-n	-	-	-	-	-	-	-	-	-	-	-	-	-	R	-	-
Acetylene Gas, 100%	N	-	-	N	-	-	-	-	R	-	-	-	-	R	-	-
Acetylene Tetrabromide	-	-	-	-	-	-	-	-	-	-	-	-	-	N	-	-
Acetylnitrile	-	-	N	N	N	-	-	-	-	R	R	-	-	-	-	-
Acetylsalicylic Acid	-	-	-	-	-	-	-	-	-	-	-	-	-	-	R	-
Acetylonitrile	N	-	-	N	-	-	-	-	C	-	-	-	-	R	-	-
Adipic Acid, Sat'd	-	R	R	C	R	-	-	-	-	R	R	R	R	R	R	-
Aero Lubriplate	-	-	-	-	-	-	-	-	-	-	-	-	-	-	-	-
Alanine-dl	-	-	-	-	-	-	-	-	-	-	-	-	-	R	-	-
Alcohols	R	-	-	R	-	-	-	-	R	-	-	-	-	-	-	-
Allyl Alcohol,96%	C	N	N	R	-	-	-	-	R	R	R	-	R	R	-	-
Allyl Chloride	N	-	-	N	-	-	-	-	-	-	-	-	-	-	-	-
Aloin	-	-	-	-	-	-	-	-	-	-	-	-	-	R	-	-

In the table the figure stands for the below mentioned:

R - Stands for recommended | **C** - Stands for use with caution | **N** - Stands for not recommended

PP-R IS AN IDEAL MATERIAL FOR HOT & COLD WATER PLUMBING SYSTEMS

CHEMICAL RESISTANCE CHART

Chemical	PVC			CPVC					PPR					HDPE		
	20	40	60	20	40	60	80	100	20	40	60	80	100	20	40	60
Temp in °C	68	104	140	68	104	140	176	212	68	104	140	176	212	68	104	140
Temp in °F																
Aluminum Acetate, Sat'd	R	-	-	R	-	-	-	-	R	-	-	-	-	R	-	-
Aluminum Ammonium	R	-	-	R	-	-	-	-	R	-	-	-	-	R	-	-
Aluminum Bromide	R	-	-	R	-	-	-	-	R	-	-	-	-	-	-	-
Aluminum Chloride, Sat'd	R	R	R	R	-	R	-	-	R	R	R	R	C	R	-	-
Aluminum Fluoride, Sat'd	R	-	R	R	-	-	-	-	R	-	-	-	-	R	-	-
Aluminum Hydroxide, Sat'd	R	-	R	R	-	-	-	-	R	-	-	-	-	R	-	-
Aluminum Nitrate Sat'd	R	-	R	R	-	-	-	-	R	-	-	-	-	R	-	-
Aluminum Oxalate	-	-	-	-	-	-	-	-	-	-	-	-	-	C	-	-
Aluminum Oxide	-	-	-	-	-	-	-	-	-	-	-	-	R	-	-	-
Aluminum Oxychloride	R	-	-	R	-	-	-	-	R	-	-	-	-	-	-	-
Aluminum Potassium Sulfate, Sat'd	R	-	-	R	-	-	-	-	R	-	-	-	-	R	-	-
Aluminum Salts	-	-	-	-	-	-	-	-	-	-	-	-	-	-	-	-
Aluminum Sodium Sulfate	-	-	-	-	-	-	-	-	-	-	-	-	R	-	-	-
Aluminum Sulfate, Sat'd	R	R	R	R	-	R	-	R	R	R	R	R	R	R	-	-
Alums, NH3-Cr-K	-	-	-	-	-	-	-	-	-	-	-	-	-	-	-	-
Ambrex 33 (Mobil)	-	-	-	-	-	-	-	-	-	-	-	-	-	-	-	-
Ambrex 830 (Mobil)	-	-	-	-	-	-	-	-	-	-	-	-	-	-	-	-
Amines	-	-	-	-	-	-	-	-	-	-	-	-	-	-	-	-
Amino Acetic Acid	-	-	-	-	-	-	-	-	-	-	-	-	-	R	-	-
Aminobutric-a-dl Acid	-	-	-	-	-	-	-	-	-	-	-	-	-	R	-	-
Aminoisobutyric-2 Acid	-	-	-	-	-	-	-	-	-	-	-	-	-	R	-	-
Ammonia Anhydrous	-	-	-	-	-	-	-	-	-	-	-	-	-	C	-	-
Ammonia Gas 1	-	-	R	-	-	-	-	R	-	-	-	-	R	-	-	-
Ammonia Gas, Cold	R	R	R	-	-	-	-	-	R	R	R	-	-	-	-	-
Ammonia Liquid 2	-	N	R	-	-	-	-	R	-	-	-	-	R	-	-	-
Ammonium Acetate, Sat'd 1	R	C	R	-	-	-	-	R	R	R	R	R	R	-	-	-
Ammonium Benzoate	-	-	-	R	-	-	-	-	R	-	-	-	-	R	-	-
Ammonium Bifluoride, Sat'd	R	-	-	R	-	-	-	-	R	-	-	-	-	R	-	-
Ammonium Bisulfide	R	-	-	-	-	-	-	-	-	-	-	-	-	-	-	-
Ammonium Bromide Ammonium Carbonate, Sat'd	R	R	C	R	-	-	-	-	R	R	R	R	R	R	-	-
Ammonium Chloride, Sat'd	R	-	R	R	-	R	-	R	R	-	R	-	C	R	R	R
Ammonium Citrate	-	-	-	R	-	-	-	-	-	-	-	-	-	-	-	-
Ammonium Dichromate	R	-	-	R	-	-	-	-	-	-	-	-	-	C	-	-
Ammonium	-	-	-	-	-	-	-	-	-	-	-	-	-	-	-	-
Ammonium Fluoride, 10%	R	-	-	R	-	-	-	-	R	-	-	-	-	R	-	-
Ammonium Fluoride, 20%	R	-	C	R	-	R	-	-	R	-	R	-	-	-	-	-
Ammonium Fluoride, 25%	R	-	C	R	-	R	-	-	R	-	R	-	-	R	-	-
Ammonium Fluoro Silicate	-	-	-	-	-	-	-	-	-	-	-	-	-	-	-	-
Ammonium Glycolate	-	-	-	-	-	-	-	-	-	-	-	-	-	R	-	-
Ammonium Hydroxide	R	R	R	-	R	R	R	-	R	R	R	R	R	R	-	-
Ammonium 1	-	-	R	-	-	-	-	R	-	-	-	-	R	-	-	-

In the table the figure stands for the below mentioned:

R - Stands for recommended | **C** - Stands for use with caution | **N** - Stands for not recommended

CHEMICAL RESISTANCE CHART

Chemical	PVC			CPVC					PPR					HDPE		
	20	40	60	20	40	60	80	100	20	40	60	80	100	20	40	60
Temp in °C	68	104	140	68	104	140	176	212	68	104	140	176	212	68	104	140
Temp in °F																
Ammonium Molybdate	-	-	-	-	-	-	-	-	-	-	-	-	-	-	-	-
Ammonium Nitrate, Sat'd	R	-	R	R	-	R	-	R	R	-	R	-	R	R	-	-
Ammonium Nitrite	-	-	-	-	-	-	-	-	-	-	-	-	-	-	-	-
Ammonium Oxalate	-	-	-	-	-	-	-	-	-	-	-	-	-	-	-	-
Ammonium Oxylate	-	-	-	-	-	-	-	-	-	-	-	-	-	C	-	-
Ammonium Persulfate	R	-	R	R	-	-	-	-	R	-	-	-	-	R	-	-
Ammonium Persulfate, 10%	-	-	-	-	-	-	-	-	-	-	-	-	-	-	-	-
Ammonium Phosphate, Dibasic	R	R	R	R	-	C	-	-	R	R	R	R	R	R	-	-
Ammonium Phosphate, Monobasic	R	R	R	R	-	-	-	-	R	R	R	R	R	R	-	-
Ammonium Phosphate	R	R	R	R	-	-	-	-	R	R	R	R	R	R	-	-
Ammonium Potassium	R	-	-	R	-	-	-	-	R	-	-	-	-	R	-	-
Ammonium Sulfamate	-	-	-	R	-	-	-	-	-	-	-	-	-	-	-	-
Ammonium Sulfate	R	R	C	R	-	-	-	-	R	R	R	R	R	R	-	-
Ammonium Sulfide, Dilute	R	-	C	R	-	-	-	-	R	-	R	-	-	R	-	-
Ammonium Sulfocyanide fmmonium Tartarate	-	-	-	R	-	-	-	-	-	-	-	-	-	-	-	-
Ammonium Thiocyanate	R	-	-	R	-	-	-	-	R	-	-	-	-	R	-	-
Ammonium Thioglycolate	-	-	-	-	-	-	-	-	-	-	-	-	-	C	-	-
Amonia Acetate, Sat'd	R	-	-	R	-	-	-	-	R	-	-	-	-	R	-	-
Amonia Gas 1	-	-	N	-	-	-	-	R	-	-	-	-	R	-	-	-
Amonia Liquid 3	-	-	N	-	-	-	-	R	-	-	-	-	R	-	-	-
Amyl Acetate 3	-	N	N	-	N	-	-	C	C	-	-	-	R	-	-	-
Amyl Alcohol, Pure	R	R	C	R	-	R	-	R	R	R	R	R	R	R	-	-
Amyl Borate	-	-	-	-	-	-	-	-	-	-	-	-	-	-	-	-
Amyl Chloride 3	-	-	N	-	-	-	-	N	-	-	-	-	-	-	-	-
Amyl Chloronaphthalene	-	-	-	-	-	-	-	-	-	-	-	-	-	-	-	-
Amyl Naphthalene	-	-	-	-	-	-	-	-	-	-	-	-	-	-	-	-
Amyl Phthalate	-	-	-	-	-	-	-	-	-	-	-	-	R	-	-	-
Ang-25 (Glycerol Ester)	-	-	-	-	-	-	-	-	-	-	-	-	-	-	-	-
Aniline 3	-	N	N	-	N	-	N	C	-	-	-	-	R	-	-	-
Aniline Chlorohydrate	C	-	N	N	-	N	-	N	C	-	C	-	N	-	-	-
Aniline Dyes	-	-	-	-	-	-	-	-	-	-	-	-	-	-	-	-
Aniline Hydrochloride, Aniline Sulphate	R	C	-	N	-	-	-	-	R	R	C	-	-	R	-	-
Animal Oil	-	-	-	-	-	-	-	-	-	-	-	-	-	-	-	-
Anthranilic Acid	-	-	-	-	-	-	-	-	-	-	-	-	R	-	-	-
Anthraquinone 1	-	-	R	-	-	-	-	R	-	-	-	-	-	-	-	-
Anthraquinone Sulfonic	R	-	-	R	-	-	-	-	R	-	-	-	-	R	-	-
Antimony Trichloride	R	R	R	R	-	-	-	-	R	R	R	-	-	R	-	-
Aqua Regia 1	C	C	C	C	C	C	C	C	N	N	N	N	N	-	-	-
Arachidic Acid	-	-	-	-	-	-	-	-	-	-	-	-	-	-	-	-
Argon, Dry	-	-	-	-	-	-	-	-	-	-	-	-	-	-	-	-

In the table the figure stands for the below mentioned:

R - Stands for recommended | **C** - Stands for use with caution | **N** - Stands for not recommended

PP-R IS AN IDEAL MATERIAL FOR HOT & COLD WATER PLUMBING SYSTEMS

CHEMICAL RESISTANCE CHART

Chemical	PVC			CPVC					PPR					HDPE		
	20	40	60	20	40	60	80	100	20	40	60	80	100	20	40	60
Temp in °C	20	40	60	20	40	60	80	100	20	40	60	80	100	20	40	60
Temp in °F	68	104	140	68	104	140	176	212	68	104	140	176	212	68	104	140
Aromatic Fuel, 50%	-	-	-	-	-	-	-	-	-	-	-	-	-	-	-	-
Aromatic Hydrocarbons	N	-	-	N	-	-	-	-	-	-	-	-	-	-	-	-
Arsenic Acid, 80%	R	R	C	R	C	C	C	C	R	R	R	R	C	R	-	-
Arsenic Trioxide (Powder)	-	-	-	-	-	-	-	-	-	-	-	-	-	C	-	-
Arylsulfonic Acid 1	-	-	-	-	-	-	-	-	-	-	-	-	R	-	-	-
Ascorbic Acid	-	-	-	-	-	-	-	-	-	-	-	-	-	-	-	-
Askarel	-	-	-	-	-	-	-	-	-	-	-	-	-	-	-	-
Asphalt 3	-	-	N	-	-	-	-	R	-	-	-	-	N	-	-	-
ASTM Oil, NO.1 1	-	-	-	-	-	-	-	-	-	-	-	-	-	-	-	-
ASTM Oil, NO.2 1	-	-	-	-	-	-	-	-	-	-	-	-	-	-	-	-
ASTM Oil, NO.3 1	-	-	-	-	-	-	-	-	-	-	-	-	-	-	-	-
Atropine Sulfate	-	-	-	-	-	-	-	-	-	-	-	-	R	-	-	-
Aurex 903R (Mobile)	-	-	-	-	-	-	-	-	-	-	-	-	-	-	-	-
Automatic Transmission Automotive Brake Fluid	C	-	-	-	-	-	-	-	R	-	-	-	-	R	-	-
B																
Bardol B	-	-	-	-	-	-	-	-	-	-	-	-	-	-	-	-
Barium Acetate Sat'd	-	-	-	-	-	-	-	-	-	-	-	-	-	-	-	-
Barium Bromide	-	-	-	-	-	-	-	-	-	-	-	-	-	R	-	-
Barium Carbonate, Sat'd	R	-	R	R	-	-	-	-	R	-	R	-	-	R	-	-
Barium Chloride, Sat'd	R	R	R	R	-	-	-	-	R	-	R	-	-	R	-	-
Barium Cyanide	-	-	-	-	-	-	-	-	-	-	-	-	-	-	-	-
Barium Hydroxide,10%	R	R	R	R	-	-	-	-	R	R	R	-	-	-	-	-
Barium Hydroxide, Sat'd	R	R	R	R	-	-	-	-	R	R	R	-	-	R	-	-
Barium Nitrate, Sat'd	R	-	-	R	-	-	-	-	R	-	-	-	-	R	-	-
Barium Sulfate, Sat'd	R	R	R	R	-	-	-	-	R	-	R	-	-	R	-	-
Barium Sulfide, Sat'd	R	R	R	R	-	-	-	-	R	-	-	-	-	R	-	-
Bayol35	-	-	-	-	-	-	-	-	-	-	-	-	-	-	-	-
Bayol D	-	-	-	-	-	-	-	-	-	-	-	-	-	-	-	-
Beer	R	R	R	R	-	-	-	-	R	R	R	-	-	R	-	-
Beet Sugar Liquors	R	-	-	R	-	-	-	-	R	-	-	-	-	R	-	-
Benzal Chloride	-	-	-	-	-	-	-	-	-	-	-	-	-	-	-	-
Benzaldehyde	N	-	N	N	-	-	-	-	N	-	N	-	-	N	-	-
Benzaldehyde, 1%	-	-	-	-	-	-	-	-	-	-	-	-	-	-	-	-
Benzaldehyde, 10%	R	-	-	R	-	-	-	-	R	-	-	-	-	R	-	-
Benzaldehyde, >10%	N	-	-	-	-	-	-	-	-	-	-	-	-	-	-	-
Benzaldehyde, 10%	-	-	-	-	-	-	-	-	-	-	-	-	-	R	-	-
Benzaldehyde, 5%	-	-	-	-	-	-	-	-	-	-	-	-	-	R	-	-
Benzalkonium Chloride	R	-	-	-	-	-	-	-	-	-	-	-	-	C	-	-
Benzamide	-	-	-	-	-	-	-	-	-	-	-	-	-	-	-	-
Benzene	N	N	N	N	-	-	-	-	C	-	N	-	N	C	-	-
Benzene Sulfonic Acid, Sat'd	N	N	N	N	N	N	N	N	R	R	R	N	N	R	R	C

In the table the figure stands for the below mentioned:

R - Stands for recommended | **C** - Stands for use with caution | **N** - Stands for not recommended

CHEMICAL RESISTANCE CHART

Chemical	PVC			CPVC					PPR					HDPE		
	20	40	60	20	40	60	80	100	20	40	60	80	100	20	40	60
Temp in °C	68	104	140	68	104	140	176	212	68	104	140	176	212	68	104	140
Temp in °F																
Benzene Sulfonic Acid,10%	N	N	N	N	N	N	N	N	R	C	N	-	-	N	-	-
Benzenesulfonic Acid	N	-	-	N	-	-	-	-	N	-	-	-	-	R	-	-
Benzenesulfonic Acid,10%	R	-	-	R	-	-	-	-	R	-	-	-	-	R	-	-
Benzine	R	R	R	-	-	-	-	-	C	-	-	-	-	-	-	-
Benzochloride	-	-	-	-	-	-	-	-	-	-	-	-	-	-	-	-
Benzoic Acid, All	R	R	C	R	-	C	-	-	R	R	R	R	R	R	-	-
Benzoic Acid Crystals	-	-	-	-	-	-	-	-	-	-	-	-	-	-	-	-
Benzoic Sulfimide	-	-	-	-	-	-	-	-	-	-	-	-	-	-	-	-
Benzophenone	-	-	-	-	-	-	-	-	-	-	-	-	-	-	-	-
Benzotrichloride	-	-	-	-	-	-	-	-	-	-	-	-	-	-	-	-
Benzotrifluoride	-	-	-	-	-	-	-	-	-	-	-	-	-	-	-	-
Benzoyl Benzoic Acid	-	-	-	-	-	-	-	-	-	-	-	-	-	-	-	-
Benzoyl Chloride	-	-	-	-	-	-	-	-	-	-	-	-	-	-	-	-
Benzyl Acetate	-	-	-	-	-	-	-	-	-	-	-	-	-	C	-	-
Benzyl Alcohol	C	-	-	R	-	-	-	-	R	R	C	-	-	R	-	-
Benzyl Alcohol,1,5%	-	-	-	-	-	-	-	-	-	-	-	-	-	-	-	-
Benzyl Benzoate	-	-	-	-	-	-	-	-	-	-	-	-	-	-	-	-
Benzyl Chloride	-	-	-	-	R	-	-	-	-	-	-	-	-	-	-	-
Beryllium Sulfate	-	-	-	-	-	-	-	-	-	-	-	-	-	-	-	-
Bismuth Carbonate	R	-	-	-	R	-	-	-	R	-	-	-	-	R	-	-
Black Liquor	R	-	-	-	R	-	-	-	R	-	-	-	-	R	-	-
Black Point 77	-	-	-	-	-	-	-	-	-	-	-	-	-	-	-	-
Blast Furnace Gas	-	-	-	-	-	-	-	-	-	-	-	-	-	-	-	-
Bleach, 12% Active Cl2	-	-	-	R	-	-	-	-	R	-	-	-	-	-	-	-
Bleach, 5% Active Cl2	R	-	-	R	-	-	-	-	R	-	-	-	-	-	-	-
Bleach Liauor	-	-	-	-	-	-	-	-	-	-	-	-	-	-	-	-
Blood	-	-	-	-	-	-	-	-	-	-	-	-	-	-	-	-
Borax, Sat'd	R	R	C	R	-	-	-	-	R	R	R	R	R	R	-	-
Bordeaux Mixture	-	-	-	-	-	-	-	-	-	-	-	-	-	-	-	-
Boric Acid, 10%	R	-	C	R	R	R	R	R	R	R	R	R	R	R	-	-
Boric Acid, Sat'd	-	-	-	-	-	-	-	-	-	-	-	-	-	-	-	-
Boron Fluids (HEF)	-	-	-	-	-	-	-	-	-	-	-	-	-	-	-	-
Boron Trifluoride	-	-	-	-	-	-	-	-	-	-	-	-	-	C	-	-
Brake Fluid	-	-	-	-	-	-	-	-	-	-	-	-	-	-	-	-
Brine, Sat'd	R	R	R	R	-	R	-	-	R	R	R	R	R	-	-	-
Brom-113	-	-	-	-	-	-	-	-	-	-	-	-	-	-	-	-
Brom-114	-	-	-	-	-	-	-	-	-	-	-	-	-	-	-	-
Bromic Acid	R	-	-	R	-	-	-	-	N	-	-	-	-	-	-	-
Bromic Acid, 10%	R	-	R	R	-	R	-	R	-	-	-	-	-	-	-	-
Bromine, Aqueous	-	-	-	-	-	-	-	-	-	-	-	-	-	-	-	-
Bromine Liquid	N	-	N	N	-	N	-	N	N	-	N	-	N	N	-	-
Bromine Pentafluoride	-	-	-	-	-	-	-	-	-	-	-	-	-	-	-	-

In the table the figure stands for the below mentioned:

R - Stands for recommended | **C** - Stands for use with caution | **N** - Stands for not recommended

PP-R IS AN IDEAL MATERIAL FOR HOT & COLD WATER PLUMBING SYSTEMS

CHEMICAL RESISTANCE CHART

Chemical	PVC			CPVC					PPR					HDPE		
	20	40	60	20	40	60	80	100	20	40	60	80	100	20	40	60
Temp in °C	20	40	60	20	40	60	80	100	20	40	60	80	100	20	40	60
Temp in °F	68	104	140	68	104	140	176	212	68	104	140	176	212	68	104	140
Bromine Trifluoride	-	-	-	-	-	-	-	-	-	-	-	-	-	-	-	-
Bromine Vapor, 25%	R	-	-	R	-	-	-	-	N	-	-	-	-	R	-	-
Bromine Water cold, Sat'd	N	-	-	-	-	-	-	-	-	-	-	-	-	N	-	-
Bromoacetic Acid	-	-	-	-	-	-	-	-	-	-	-	-	-	-	-	-
Bromobenzene	-	-	-	-	-	-	-	-	-	-	-	-	-	N	-	-
Bromobutyric-2 Acid	-	-	-	-	-	-	-	-	-	-	-	-	-	C	-	-
Bromochloro	-	-	-	-	-	-	-	-	-	-	-	-	-	-	-	-
Bromoform	-	-	-	-	-	-	-	-	-	-	-	-	-	N	-	-
Bromosalicylic Acid, Sat'd	-	-	-	-	-	-	-	-	-	-	-	-	-	R	-	-
Bromotoluene	N	-	-	-	-	-	-	-	-	-	-	-	-	N	-	-
Bunker Oil	-	-	-	-	-	-	-	-	-	-	-	-	-	-	-	-
Butadiene	R	-	R	R	-	-	-	-	R	R	R	-	-	-	-	-
Butadiene, 50%	R	-	-	R	-	-	-	-	N	-	-	-	-	R	-	-
Butadiene Gas	R	-	-	R	-	-	-	-	R	-	-	-	-	-	-	-
Butanane- 2, 4-p-Methoxy	-	-	-	-	-	-	-	-	-	-	-	-	-	N	-	-
Butane, 50%	R	-	-	R	-	-	-	-	R	-	-	-	-	R	-	-
Butane, Gas	R	-	-	R	-	-	-	-	R	-	-	-	-	-	-	-
Butter - Animal Fat	-	-	-	-	-	-	-	-	-	-	-	-	-	-	-	-
Butyl Acetate	N	-	N	N	-	N	-	N	C	-	-	-	-	-	-	-
Butyl Acetyl Ricinoleate	-	-	-	-	-	-	-	-	-	-	-	-	-	-	-	-
Butyl Acrylate Pure	N	-	-	N	-	-	-	-	N	-	-	-	-	-	-	-
Butyl Alcohol	R	-	C	R	R	-	-	-	R	-	R	-	C	R	-	-
Butyl Benzoate	-	-	-	-	-	-	-	-	-	-	-	-	-	-	-	-
Butyl Bromide	-	-	-	-	-	-	-	-	-	-	-	-	R	-	-	-
Butyl Butyrate	-	-	-	-	-	-	-	-	-	-	-	-	-	-	-	-
Butyl Carbitol	-	-	-	-	-	-	-	-	-	-	-	-	-	-	-	-
Butyl Cellosolve	-	-	-	-	-	-	-	-	-	-	-	-	-	-	-	-
Butyl Cellosolve"Adipate	-	-	-	N	-	-	-	-	-	-	-	-	-	N	-	-
Butyl Chloride	-	-	-	-	-	-	-	-	-	-	-	-	-	-	-	-
Butyl Ether	N	-	-	N	-	-	-	-	N	-	-	-	-	-	-	-
Butyl Glycolate	-	-	-	-	-	-	-	-	-	-	-	-	-	-	-	-
Butyl Mercaptan	-	-	-	-	-	-	-	-	-	-	-	-	-	-	-	-
Butyl Oleate	-	-	-	-	-	-	-	-	-	-	-	-	-	-	-	-
Butyl Pheno	C	-	C	R	-	-	-	-	N	N	-	-	-	R	-	-
Butyl Phthalate	N	-	-	N	-	-	-	-	-	-	-	-	-	-	-	-
Butylamine, Sal'd	-	-	-	-	-	-	-	-	-	-	-	-	-	-	-	-
Butylene, liquid	C	-	-	-	-	-	-	-	-	-	-	-	-	-	-	-
Butyric Acid	R	-	-	-	-	-	-	-	R	R	C	-	-	-	-	-
Butyric Acid, pure	R	-	-	-	-	-	-	-	R	R	C	-	-	-	-	-
C																
Calcium Bisulfide	R	R	R	R	-	-	-	-	R	R	R	-	-	-	-	-
Calcium Bisulfite	R	R	R	R	-	-	-	-	R	R	R	-	-	-	-	-

In the table the figure stands for the below mentioned:

R - Stands for recommended | **C** - Stands for use with caution | **N** - Stands for not recommended

CHEMICAL RESISTANCE CHART

Chemical	PVC			CPVC					PPR					HDPE		
	20	40	60	20	40	60	80	100	20	40	60	80	100	20	40	60
Temp in °C	68	104	140	68	104	140	176	212	68	104	140	176	212	68	104	140
Temp in °F																
Calcium Carbonate	R	R	R	R	R	R	-	-	R	R	R	-	-	-	-	-
Calcium Chlorate	R	R	R	R	-	-	-	-	R	-	-	-	-	-	-	-
Calcium Chloride, Sat'd	R	-	C	R	-	-	-	-	R	R	R	-	C	-	-	-
Calcium Hydroxide,30%	R	R	R	R	-	-	-	-	R	R	R	-	-	-	-	-
Calcium Hydroxide, Sat'd	R	R	R	-	-	-	-	-	R	R	R	R	-	-	-	-
Calcium Hypochlorite	-	C	-	-	-	-	-	-	R	R	-	-	-	-	-	-
Calcium Nitrate, Sat'd	R	R	R	R	R	R	-	-	R	-	-	-	-	-	-	-
Calcium Sulfate	R	R	R	R	-	-	-	-	R	-	-	-	-	-	-	-
Calcium Sulfide, Sa'd	R	R	R	R	-	-	-	-	R	-	-	-	-	-	-	-
Camphor Oil	R	-	-	-	-	-	-	-	N	N	N	-	-	-	-	-
Carbon Dioxide, Pure Anhydrous	R	R	R	R	R	R	R	-	R	R	R	R	-	R	R	R
Carbon Dioxide, Pure Moist	R	R	R	R	R	R	R	-	R	R	R	R	-	R	R	R
Carbon Disulfide	C	-	N	N	-	N	-	N	R	-	N	-	N	-	-	-
Carbon Monoxide, Gas	R	R	R	R	-	-	-	-	R	R	R	-	-	-	-	-
Carbon Tetrachloride	C	-	N	R	-	-	-	-	N	N	N	-	-	-	-	-
Carbonic Acid, Sat'd	R	R	R	R	-	-	-	-	-	-	-	-	-	-	-	-
Caustic Potash, 50%	R	R	C	-	-	-	-	-	R	R	R	R	R	-	-	-
Caustic Soda, 10%	R	R	C	-	-	-	-	-	R	R	R	R	R	-	-	-
Caustic Soda, 50%	R	R	R	-	-	-	-	-	R	R	R	R	R	-	-	-
Caustic Soda, up to 40%	R	R	C	-	-	-	-	-	R	R	R	R	R	-	-	-
Chloral Hydrate, All	-	-	-	-	-	-	-	-	C	-	-	-	-	-	-	-
Chloramine (Diluted)	R	-	-	R	-	-	-	-	R	-	-	-	-	-	-	-
Chloric Acid, 10%	R	R	C	-	-	-	-	-	-	-	-	-	-	-	-	-
Chloric Acid, 20%	R	R	C	R	-	-	-	-	R	-	N	N	N	-	-	-
Chlorinated Water, 0.3%(Sat'd 1	-	R	R	R	R	R	R	-	C	-	-	-	-	R	R	R
Chlorine, Liquid	N	-	-	-	-	-	-	-	N	N	N	-	-	-	-	-
Chloroacetic Acid, 50%	R	R	C	-	-	-	-	-	R	R	R	-	-	-	-	-
Chlorobenzene, Dry	N	N	N	N	N	-	-	-	N	N	N	-	-	-	-	-
Chloroform, Dry	N	N	-	N	N	N	N	N	C	-	N	-	N	-	-	-
Chlorosulfonic Acid	C	-	N	-	-	-	-	-	N	N	N	N	N	-	-	-
Chrome Alum	R	R	C	R	R	R	R	R	R	R	R	-	C	-	-	-
Chromic Acid, 10%	R	-	C	R	R	R	R	R	R	-	C	-	N	-	-	-
Chromic Acid, 30%	R	-	C	R	R	R	R	R	C	-	N	-	N	-	-	-
Chromic Acid, 50%	R	R	C	R	-	-	-	C	C	-	N	N	N	-	-	-
Cider	R	-	-	R	-	-	-	-	R	-	-	-	-	R	-	-
Coconut Oil	R	R	C	-	-	-	-	-	R	R	R	-	-	-	-	-
Compressed Air	C	-	-	-	-	-	-	-	C	-	-	-	-	R	R	-
Copper Chloride, Sat'd	R	-	R	R	R	R	R	R	R	R	R	-	-	-	-	-
Copper Cyanide	N	N	N	R	-	-	-	-	R	R	R	-	-	-	-	-
Copper Fluoborate	R	R	R	R	-	-	-	-	N	N	N	-	-	-	-	-
Copper Nitrate, 30%	R	-	C	R	-	-	-	-	R	R	R	-	-	-	-	-
Copper Salts	R	R	C	-	-	-	-	-	R	R	C	-	-	R	R	R

In the table the figure stands for the below mentioned:

R - Stands for recommended | **C** - Stands for use with caution | **N** - Stands for not recommended

PP-R IS AN IDEAL MATERIAL FOR HOT & COLD WATER PLUMBING SYSTEMS

CHEMICAL RESISTANCE CHART

Chemical	PVC			CPVC					PPR					HDPE		
	20	40	60	20	40	60	80	100	20	40	60	80	100	20	40	60
Temp in °C	68	104	140	68	104	140	176	212	68	104	140	176	212	68	104	140
Temp in °F																
Copper Sulfate, Sat'd	R	R	R	R	R	R	-	-	R	R	R	-	-	-	-	-
Cottonseed Oil	R	R	R	R	-	-	-	-	R	R	R	-	-	-	-	-
Creosols	C	-	N	C	-	N	-	-	R	-	-	-	-	-	-	-
Creosylic Acid	C	-	N	R	-	-	-	-	-	-	-	-	-	-	-	-
Cresol, 50%	C	-	N	C	-	N	-	-	R	-	-	-	-	-	-	-
Cresol, 90%	N	N	N	N	N	N	-	-	C	-	-	-	-	-	-	-
Cyclohexane	N	N	N	N	N	N	-	-	R	-	C	-	-	R	R	R
Cyclohexanol	R	R	R	-	-	-	-	-	R	R	C	-	-	R	R	R
Cyclohexanone	N	N	N	N	N	N	N	N	R	C	N	N	N	R	C	C
D																
Decahydronaphthalene	R	R	R	-	-	-	-	-	N	N	N	-	-	-	-	-
Detergent, Water Solution	R	R	C	-	-	-	-	-	R	R	R	R	-	-	R	R
Di (Butoxyethyl) Phthalate	N	N	N	N	N	N	-	-	N	-	-	-	-	-	-	-
Dibutyl Phthalate	-	-	-	-	-	-	-	-	R	C	C	-	-	R	C	C
Dibutyl Sebacate	-	-	-	-	-	-	-	-	R	-	-	-	-	R	-	-
Dichloro Ethane	-	-	-	-	-	-	-	-	C	-	-	-	-	C	-	-
Dichlorobenzene	N	N	-	N	-	-	-	-	R	-	-	-	-	-	-	-
Dichloroethylene	N	N	N	-	-	-	-	-	C	-	-	-	-	-	-	-
Diethyl Ether	N	N	N	N	N	N	-	-	R	R	R	-	-	-	-	-
Diglycolic Acid, Sat'd	R	R	C	-	-	-	-	-	R	R	R	-	-	R	R	R
Diisobutyl Ketone	-	-	-	-	-	-	-	-	R	-	-	-	-	R	-	-
Dimethylamine	C	-	R	-	-	-	-	-	R	-	C	-	-	-	-	-
Dimethylformamide	C	-	-	-	-	-	-	-	R	-	-	-	-	R	-	C
Dinonyl Phthalate	-	-	-	-	-	-	-	-	R	-	-	-	-	C	-	-
Dioctyl Phthalate	N	N	N	-	-	-	-	-	R	C	C	-	-	C	-	-
Dioxane	-	-	-	-	-	-	-	-	C	C	C	-	-	R	R	R
E																
Ethers	N	N	N	N	N	N	-	-	N	N	N	-	-	-	-	-
Ethyl Acetate	N	N	N	N	N	N	N	N	R	C	C	N	N	R	C	C
Ethyl Alcohol	R	R	C	R	-	-	-	-	R	R	R	R	R	R	R	R
Ethyl Benzene	-	-	-	-	-	-	-	-	C	-	-	-	-	-	-	-
Ethyl Ether	N	N	N	N	N	N	-	-	N	N	N	-	-	-	-	-
Ethylene Chloride	-	-	-	-	-	-	-	-	C	-	-	-	-	C	-	-
Ethylene Chlorohydrin	N	N	N	N	N	N	N	-	-	-	-	-	-	-	-	-
Ethylene Diamine	C	-	-	-	-	-	-	-	R	-	-	-	-	R	R	R
Ethylene Glycol, 100%	R	R	R	N	-	-	-	-	R	R	R	R	R	R	R	R
Ethylene Glycol, 50%	-	-	-	R	R	R	R	-	-	-	-	-	-	-	-	-
Ethylene Oxide	-	-	-	-	-	-	-	-	C	-	-	-	-	-	-	-
Fatty Acids	R	R	R	R	R	R	-	-	R	R	R	-	-	-	-	-
Fatty Alcohol. Sulfamate	R	R	C	-	-	-	-	-	R	R	C	-	-	R	R	R
Ferric Chloride	R	-	C	R	-	-	-	-	R	R	R	-	-	-	-	-
Ferric Chloride, Sat'd	R	R	R	R	R	R	R	R	R	R	R	R	R	-	-	-

In the table the figure stands for the below mentioned:

R - Stands for recommended | **C** - Stands for use with caution | **N** - Stands for not recommended

CHEMICAL RESISTANCE CHART

Chemical	PVC			CPVC					PPR					HDPE		
	20	40	60	20	40	60	80	100	20	40	60	80	100	20	40	60
Temp in °C	20	40	60	20	40	60	80	100	20	40	60	80	100	20	40	60
Temp in °F	68	104	140	68	104	140	176	212	68	104	140	176	212	68	104	140
Ferric Nitrate, Sat'd	R	R	R	R	-	-	-	-	-	-	-	-	-	-	-	-
Ferric Sulfate	R	R	R	R	-	-	-	-	R	-	-	-	-	-	-	-
Ferrous Chloride, Sat'd	R	R	R	R	R	R	-	-	R	-	-	-	-	-	-	-
Ferrous Sulfate	R	R	R	R	-	-	-	-	R	-	-	-	-	-	-	-
Fluorine Gas (Dry),100%	C	-	N	-	-	-	-	-	N	N	N	-	-	-	-	-
Fluosilicic Acid, 30%	R	R	R	R	R	R	R	R	R	R	R	-	-	-	-	-
Formaldehyde	R	-	C	R	-	-	-	C	R	R	R	-	-	-	-	-
Formamide	-	-	-	-	-	-	-	-	R	R	R	-	-	R	R	R
Freon 12, 100%	R	-	-	-	-	-	-	-	-	-	-	-	-	-	-	-
Fruit Juice, Pure	R	R	R	-	-	-	-	-	R	R	R	R	R	R	R	R
Furfuryl Alcohol	-	-	-	-	-	-	-	-	R	-	C	-	-	R	R	R
G																
Gasoline	R	R	C	N	N	N	N	N	N	N	N	N	N	R	R	R
Gelatin	R	R	R	R	-	N	-	-	R	R	R	-	-	R	R	R
Glucose	R	R	C	R	-	-	-	-	R	R	R	R	R	-	-	-
Glycerine	R	R	R	-	-	-	-	-	R	R	R	R	R	R	R	R
Glycine, Aqueous	R	R	R	R	R	R	R	R	R	R	R	R	R	-	-	-
Glycolic Acid, Sat'd	R	-	-	-	-	-	-	-	R	-	-	-	-	R	R	R
H																
Heptane	R	-	C	R	-	-	-	-	R	-	C	-	-	R	-	C
n-Hexane	R	-	C	R	-	-	-	-	R	-	C	-	-	R	-	C
Hydrazine Hydrate	R	-	-	-	-	-	-	-	R	R	R	-	-	R	R	R
Hydrobromic Acid, 50%	R	R	R	-	-	-	-	-	R	R	R	-	-	R	R	R
Hydrochloric Acid, 10%	R	R	C	-	-	-	-	-	R	R	C	C	-	R	R	R
Hydrochloric Acid, 25%	R	-	C	R	R	R	R	R	R	R	R	R	R	-	-	-
Hydrochloric Acid, 36%	R	R	C	-	-	-	-	-	R	C	-	-	-	R	R	R
Hydrochloric Acid, 37%	R	R	R	C	-	R	-	R	R	R	R	-	C	-	-	-
Hydrocyanic Acid	R	R	C	-	-	-	-	-	R	R	R	-	-	R	R	R
Hydrofluoric Acid, 10%	R	-	C	R	-	C	-	-	R	R	R	-	N	-	-	-
Hydrofluoric Acid, 60%	C	-	N	R	-	C	-	-	R	-	N	-	N	-	-	-
Hydrogen Peroxide, 30%	R	R	R	R	R	R	R	R	R	R	R	-	-	R	R	R
Hydrogen Sulfide, Dry	R	-	C	-	-	-	-	-	R	R	R	-	-	-	-	-
Hydroxylamine Sulfate	R	R	R	-	-	-	-	-	R	R	R	-	-	R	R	R
I																
Iodine	-	-	-	-	-	-	-	-	R	-	-	-	-	R	-	C
Iso butane	R	-	-	-	-	-	-	-	C	-	N	-	-	-	-	-
Isooctane	R	-	-	-	-	-	-	-	R	-	C	-	-	R	-	C
Isopropyl Acetate	R	-	-	-	-	-	-	-	R	R	R	R	R	R	R	R
Isopropyl Alcohol	-	-	C	-	-	-	-	-	R	R	R	-	-	-	-	-
Isopropyl Ether	C	-	N	-	-	-	-	-	C	-	N	-	-	C	-	-
L																
Lactic Acid, 10%	R	C	-	-	-	-	-	-	R	R	R	R	R	R	R	R

In the table the figure stands for the below mentioned:

R - Stands for recommended | **C** - Stands for use with caution | **N** - Stands for not recommended

PP-R IS AN IDEAL MATERIAL FOR HOT & COLD WATER PLUMBING SYSTEMS

CHEMICAL RESISTANCE CHART

Chemical	PVC			CPVC					PPR					HDPE		
Temp in °C	20	40	60	20	40	60	80	100	20	40	60	80	100	20	40	60
Temp in °F	68	104	140	68	104	140	176	212	68	104	140	176	212	68	104	140
Lanolin	R	C	-	-	-	-	-	-	R	R	R	-	-	R	R	R
Lead Acetate, Sat'd	R	R	R	R	R	R	R	R	R		C	C	C	R	R	R
Linseed Oil	R	R	C	R	-	-	-	-	R	R	R	R	R	R	R	R
Liqueurs	R	R	-	-	-	-	-	-	R	-	-	-	-	R	R	-
M																
Magnesium Carbonate	R	-	R	R	-	-	-	-	R	R	R	-	-	-	-	-
Magnesium Chloride, Sat'd	R	R	R	R	R	R	R	R	R	R	R	-	C	-	-	-
Magnesium Hydroxide	R	R	R	R	R	R	R	-	R	R	R	R	-	R	R	R
Magnesium Nitrate	R	R	R	R	-	-	-	-	R	R	R	-	-	-	-	-
Magnesium Salts	R	R	C	-	-	-	-	-	R	R	R	R	R	R	R	R
Malic Acid	R	-	-	R	-	-	-	-	R	-	R	-	-	-	-	-
Mercuric Chloride, Sat'd	R	R	R	R	-	-	-	-	R	R	R	-	-	-	-	-
Mercuric Cyanide, Sat'd	R	R	R	R	-	-	-	-	R	R	R	-	-	-	-	-
Mercurous Nitrate, Sat'd	R	R	R	R	-	-	-	-	R	R	R	-	-	-	-	-
Mercury	R	R	R	R	-	-	-	-	R	R	R	-	-	R	R	R
Mercury Salts	R	R	C	-	-	-	-	-	R	R	R	-	-	R	R	R
Methane	R	-	-	-	-	-	-	-	R	-	-	-	-	R	-	-
Methyl Acetate	-	-	-	-	-	-	-	-	R	R	R	-	-	R	-	-
Methyl Alcohol	R	R	R	R	-	-	-	-	R	-	C	-	C	-	-	-
Methyl Amine	C	-	N	-	-	-	-	-	R	-	C	-	-	R	-	-
Methyl Bromide	N	-	-	-	-	-	-	-	N	N	N	-	-	-	-	-
Methylene Chloride	N	-	N	N	-	N	-	N	N	-	N	-	N	C	-	-
Methylsulfuric Acid	R	-	C	R	-	-	-	-	N	-	N	-	N	C	-	-
Milk	R	R	R	R	R	R	R	R	R	R	R	R	R	-	-	-
Molasses	R	R	R	R	R	R	R	R	R	R	R	R	R	R	R	R
Morpholine	-	-	-	-	-	-	-	-	R	R	R	-	-	R	R	-
N																
Naphtha	C	-	N	R	-	-	-	-	R	-	N	-	-	-	-	-
Naphthalene	-	-	-	-	-	-	-	-	-	-	-	-	-	R	-	C
Nickel Chloride, Sat'd	R	R	R	R	R	R	R	R	R	R	R	R	R	-	-	-
Nickel Nitrate	R	R	R	R	-	-	-	-	R	R	R	-	C	-	-	-
Nickel Sulfate, Sat'd	R	R	R	R	-	-	-	-	R	R	R	-	-	-	-	-
Nitric Acid, 100%	-	-	-	-	-	-	-	-	-	-	-	-	-	-	-	-
Nitric Acid, 40%	R	R	R	R	R	R	R	R	C	-	N	-	N	-	-	-
Nitric Acid, 60%	R	-	C	R	R	R	R	R	C	-	N	-	N	-	-	-
Nitric Acid, 65%	C	C	-	-	-	-	-	-	-	-	-	-	-	C	-	-
Nitrobenzene	N	N	N	N	N	N	-	-	R	-	C	-	-	-	-	-
O																
Oleic Acid	R	R	R	R	-	-	-	-	R	R	C	-	-	R	R	C
Oleum	-	-	-	-	-	-	-	-	-	-	-	-	-	-	-	-
Olive Oil	R	R	C	-	-	-	-	-	R	R	R	R	R	R	R	C
Oxygen Gas	R	R	R	R	R	R	-	-	N	N	N	-	-	-	-	-

In the table the figure stands for the below mentioned:

R - Stands for recommended | **C** - Stands for use with caution | **N** - Stands for not recommended

CHEMICAL RESISTANCE CHART

Chemical	PVC			CPVC					PPR					HDPE		
Temp in °C	20	40	60	20	40	60	80	100	20	40	60	80	100	20	40	60
Temp in °F	68	104	140	68	104	140	176	212	68	104	140	176	212	68	104	140
Ozone	R	R	C	R	-	-	-	-	C	N	N	-	-	C	-	-
P																
Palmitic Acid	R	-	-	-	-	-	-	-	C	-	-	-	-	C	-	-
Palmitic Acid, 10%	R	R	R	R	-	-	-	-	-	-	N	-	-	-	-	-
Palmitic Acid, 70%	R	R	R	R	-	-	-	-	-	-	N	-	-	-	-	-
Paraffin	-	-	-	C	-	-	-	-	-	-	R	-	-	-	-	-
Paraffin Emulsion	R	R	R	R	-	-	-	-	R	R	C	-	-	R	R	C
Perchloric Acid, 10%	R	R	R	R	-	-	-	-	R	R	R	-	-	R	R	R
Perchloric Acid, 70%	R	-	C	-	-	-	-	-	R	-	-	-	-	R	R	R
Perchloroethylene	-	-	-	-	-	-	-	-	C	-	-	-	-	C	-	-
Petroleum	R	-	-	-	-	-	-	-	R	C	C	-	-	R	R	C
Phenol, 90%	R	C	-	-	-	-	-	-	R	R	R	-	-	R	R	C
Phenyl Hydrazine	N	N	N	N	N	N	-	-	C	C	C	-	-	C	-	-
Phosgene Gas	R	C	C	-	-	-	-	-	C	-	-	-	-	C	-	-
Phosgene Liquid	-	-	-	-	-	-	-	-	C	-	-	-	-	-	-	-
Phosphoric Acid, 25%	R	-	C	R	-	-	-	C	R	R	R	R	R	-	-	-
Phosphoric Acid, 30%	R	R	C	-	-	-	-	-	R	R	R	R	-	R	R	R
Phosphoric Acid, 50%	R	R	R	R	-	-	-	C	R	R	R	R	R	R	R	R
Phosphoric Acid, 85%	R	R	R	R	-	-	-	C	R	R	R	R	R	R	R	C
Phosphorous Pentoxide	R	R	-	-	-	-	-	-	R	-	-	-	-	R	R	-
Phosphorous Trichloride	N	N	N	N	N	N	-	-	R	-	C	-	-	-	-	-
Phosphorus Oxychloride	-	-	-	-	-	-	-	-	R	-	C	-	-	R	-	C
Phosphorus	-	-	-	-	-	-	-	-	-	-	-	-	-	-	-	-
Pentachloride	-	-	-	-	-	-	-	-	R	-	C	-	-	R	-	C
Potassium Bicarbonate	R	R	C	-	-	-	-	-	R	R	R	R	R	R	R	R
Potassium Borate	R	R	C	-	-	-	-	-	R	R	R	-	-	R	R	R
Potassium Bromate	R	R	C	R	-	-	-	-	R	R	R	R	R	R	R	C
Potassium Bromide	R	R	C	-	-	-	-	-	R	R	R	-	-	R	R	R
Potassium Carbonate	R	R	R	-	-	-	-	-	R	-	-	-	-	-	-	-
Potassium Chlorate	R	R	R	-	-	-	-	-	R	R	R	-	-	R	R	R
Potassium Chloride	R	R	R	-	-	-	-	-	R	R	R	R	R	R	R	R
Potassium Chromate	R	R	R	-	-	-	-	-	R	R	R	-	-	R	-	-
Potassium Cyanide	R	R	R	-	-	-	-	-	R	R	R	-	-	R	R	R
Potassium Ferricyanide	R	R	R	R	-	-	-	-	R	R	R	-	C	-	-	-
Potassium Fluoride	-	-	-	-	-	-	-	-	R	R	R	-	-	-	-	-
Potassium Iodide	R	R	R	-	-	-	-	-	R	R	R	-	-	R	R	R
Potassium Nitrate	R	R	R	R	R	R	R	R	R	R	R	-	-	R	R	R
Potassium Perborate	R	R	R	R	-	-	-	-	R	-	-	-	-	-	-	-
Potassium Perchlorate	R	R	C	-	-	-	-	-	R	R	R	-	-	R	R	R
Potassium	-	-	-	-	-	-	-	-	-	-	-	-	-	-	-	-
Permanganate, Sat'd	R	R	C	R	R	R	C	-	R	R	C	-	-	R	R	C
Potassium	-	-	-	-	-	-	-	-	-	-	-	-	-	-	-	-

In the table the figure stands for the below mentioned:

R - Stands for recommended | **C** - Stands for use with caution | **N** - Stands for not recommended

PP-R IS AN IDEAL MATERIAL FOR HOT & COLD WATER PLUMBING SYSTEMS

CHEMICAL RESISTANCE CHART

Chemical	PVC			CPVC					PPR					HDPE		
	20	40	60	20	40	60	80	100	20	40	60	80	100	20	40	60
Temp in °C	20	40	60	20	40	60	80	100	20	40	60	80	100	20	40	60
Temp in °F	68	104	140	68	104	140	176	212	68	104	140	176	212	68	104	140
Permanganate, 10%	R	R	C	R	R	R	R	-	R	R	R	R	-	-	-	-
Potassium Persulfate	R	R	C	R	-	-	-	-	R	R	R	-	-	R	R	R
Potassium Sulfate	R	R	C	-	-	-	-	-	R	R	R	-	-	R	R	R
Propane	R	-	-	-	-	-	-	-	R	-	-	-	-	R	-	-
1-Propanol	R	C	C	-	-	-	-	-	R	R	R	-	-	R	R	R
Propargyl Alcohol	R	R	R	-	-	-	-	-	R	R	R	-	-	R	R	R
Propionic Acid, 50%	R	R	C	-	-	-	-	-	R	R	R	-	-	R	R	R
Propyl Alcohol	R	-	C	R	-	-	-	-	R	R	R	-	-	-	-	-
Propylene Oxide	C	-	-	-	-	-	-	-	R	-	-	-	-	C	-	-
Pyridine	N	N	N	N	N	N	-	-	C	C	C	-	-	-	-	-
S																
Sea Water	R	R	R	R	R	R	R	R	R	R	R	R	R	-	-	-
Silicic Acid	R	R	R	R	-	-	-	-	R	R	R	-	-	-	-	-
Silicone Oil	R	R	N	-	-	-	-	-	R	R	R	-	-	R	R	R
Silver Cyanide	R	R	R	R	-	-	-	-	R	R	R	-	-	-	-	-
Silver Nitrate	R	-	C	R	R	R	R	R	R	R	R	-	C	-	-	-
Soaps	R	R	C	R	-	-	-	-	R	R	R	-	-	R	R	R
Sodium Acetate, Sat'd	R	R	R	R	R	R	R	R	R	R	R	R	R	R	R	R
Sodium Benzoate	R	R	C	-	-	-	-	-	R	R	R	-	-	R	R	R
Sodium Bicarbonate	R	R	R	R	R	R	R	R	R	R	R	R	-	R	R	R
Sodium Bichromate, Sat'd	R	R	R	R	R	R	R	R	R	R	R	R	R	-	-	-
Sodium Bisulfate	R	R	C	-	-	-	-	-	R	R	R	-	-	R	R	R
Sodium Bisulfite	R	R	R	R	R	R	R	R	R	R	R	-	C	R	R	R
Sodium Bromide Sat'd	R	R	R	R	-	-	-	-	R	R	R	-	-	-	-	-
Sodium Chlorate, Sat'd	R	-	C	R	-	-	-	-	R	R	R	-	-	-	-	-
Sodium Chloride	R	R	C	R	R	R	-	-	R	R	R	R	-	R	-	-
Sodium Chromate	R	R	C	-	-	-	-	-	R	R	-	-	-	R	-	-
Sodium Ferrocyanide, Sat'd 1	-	R	R	R	-	-	-	-	-	-	-	-	-	-	-	-
Sodium Fluoride	R	R	R	R	-	-	-	-	R	-	-	-	-	R	-	-
Sodium Hypochlorite	R	-	C	R	-	-	-	-	R	-	-	-	-	-	-	-
Sodium Iodide	R	R	C	-	-	-	-	-	R	-	-	-	-	R	-	-
Sodium Nitrate, Sat'd	R	R	R	R	-	-	-	-	R	R	R	-	-	R	R	R
Sodium Nitrite, Sat'd	R	-	-	-	-	-	-	-	R	-	-	-	-	R	-	-
Sodium Oxalate	R	R	C	-	-	-	-	-	R	-	-	-	-	R	-	-
Sodium Perborate	R	R	R	R	R	R	R	R	R	-	-	-	-	-	-	-
Sodium Phosphate	R	R	C	-	-	-	-	-	R	R	R	R	R	R	R	R
Sodium Sulfate, Sat'd	R	R	R	R	-	-	-	-	R	R	R	R	-	R	R	R
Sodium Sulfide	R	R	C	R	-	-	-	-	R	R	R	-	-	R	R	R
Sodium Sulfite	R	R	R	R	-	-	-	-	R	R	R	-	-	R	R	R
Sodium Thiosulfate	R	R	C	-	-	-	-	-	R	R	R	-	-	R	R	R
Stannous Chloride, 15%	R	C	C	-	-	-	-	-	R	R	R	-	-	R	R	R
Stearic Acid, 100%	R	R	R	R	R	R	-	-	R	C	C	-	-	R	-	C

In the table the figure stands for the below mentioned:

R - Stands for recommended | **C** - Stands for use with caution | **N** - Stands for not recommended

CHEMICAL RESISTANCE CHART

Chemical	PVC			CPVC					PPR					HDPE		
	20	40	60	20	40	60	80	100	20	40	60	80	100	20	40	60
Temp in °C	68	104	140	68	104	140	176	212	68	104	140	176	212	68	104	140
Temp in °F	68	104	140	68	104	140	176	212	68	104	140	176	212	68	104	140
Succinic Acid	R	R	R	-	-	-	-	-	R	R	R	-	-	R	R	R
Sugar SvruD	R	R	C	R	-	-	-	-	R	R	R	R	-	R	R	R
Sulfur Dioxide Gas, Dry	R	R	R	R	-	-	-	-	R	R	R	-	N	-	-	-
Sulfur Dioxide Gas, Wet	C	-	N	-	-	-	-	-	-	-	-	-	-	-	-	-
Sulfur Dioxide Liquified	-	-	-	-	-	-	-	-	-	-	-	-	-	-	-	-
Sulfuric Acid, 51% to 60%	R	R	R	-	-	-	-	-	R	R	R	-	-	R	R	R
Sulfuric Acid, 71% to 80%	R	R	R	-	-	-	-	-	R	R	C	-	-	R	R	C
Sulfuric Acid, 96%	R	R	C	R	-	N	-	N	N	N	N	N	N	-	-	-
Sulfuric Acid, 97%	-	-	-	-	-	-	-	-	-	-	-	-	-	-	-	-
Sulfurous Acid	R	R	C	-	-	-	-	-	R	R	R	-	-	R	R	R
T																
Tannic Acid	R	-	-	-	-	-	-	-	R	R	R	-	-	R	R	R
Tartaric Acid	R	R	C	-	-	-	-	-	R	R	R	-	-	R	R	R
Tetrachloroethane	N	N	N	-	-	-	-	-	C	-	N	-	-	C	-	-
Tetraethyl Lead	R	-	C	R	-	-	-	-	R	-	-	-	-	-	-	-
T etrahyd rofu ran	N	N	N	N	N	N	N	N	C	-	N	-	N	-	-	-
Thionyl Chloride	N	-	-	N	-	-	-	-	N	-	-	-	-	-	-	-
Toluene	N	N	N	N	N	N	N	N	C	N	N	N	N	C	-	-
Transformer Oil	R	-	C	-	-	-	-	-	R	-	C	-	-	-	-	-
Tributyl Phosphate	-	-	-	-	-	-	-	-	R	R	R	-	-	R	R	R
Trichloroacetic Acid	C	-	-	-	-	-	-	-	R	R	R	-	-	R	R	R
Trichloroacetic Acid,50%	R	C	N	-	-	-	-	-	R	R	R	-	-	R	R	R
Trichloroethylene	N	N	N	N	N	N	-	-	N	N	N	-	-	-	-	-
Tricresyl Phosphate	-	-	-	-	-	-	-	-	R	-	C	-	-	R	R	R
Triethanolam ine	C	-	N	-	-	-	-	-	R	-	-	-	-	R	R	R
Triethylamine	-	-	-	-	-	-	-	-	-	-	-	-	-	-	-	-
Trioctyl Phosphate	-	-	-	-	-	-	-	-	R	-	-	-	-	C	-	-
Turpentine	R	C	-	-	-	-	-	-	-	-	-	-	-	C	C	C
U																
Urea	R	R	C	-	-	-	-	-	R	R	R	-	-	R	R	R
Urea, 30%	-	-	-	-	-	-	-	-	-	-	-	-	-	-	-	-
Uric Acid	R	-	C	R	-	C	-	-	-	-	-	-	-	-	-	-
Urine	R	R	C	R	-	-	-	-	R	R	R	-	-	R	R	R
V																
Vaseline	R	-	N	-	-	-	-	-	R	-	C	-	-	-	-	-
Vegetable Oil	R	C	-	-	-	-	-	-	R	R	C	-	-	R	C	-
Vinegar	R	R	R	-	-	-	-	R	-	R	R	R	R	R	R	R
Vinyl Acetate	N	N	N	N	N	N	-	-	R	-	-	-	-	-	-	-
Vinyl Chloride	-	-	-	-	-	-	-	-	-	-	-	-	-	-	-	-
W																
Water, Deionized	R	R	R	-	-	-	-	-	R	R	R	R	R	R	R	R
Whiskey	R	R	R	R	-	-	-	-	R	-	-	-	-	-	-	-

In the table the figure stands for the below mentioned:

R - Stands for recommended | **C** - Stands for use with caution | **N** - Stands for not recommended

PP-R IS AN IDEAL MATERIAL FOR HOT & COLD WATER PLUMBING SYSTEMS

CHEMICAL RESISTANCE CHART

Chemical	PVC			CPVC					PPR					HDPE		
Temp in °C	20	40	60	20	40	60	80	100	20	40	60	80	100	20	40	60
Temp in °F	68	104	140	68	104	140	176	212	68	104	140	176	212	68	104	140
Wines	R	R	R	R	R	R	R	R	R	R	R	-	-	-	-	-
X																
Xylene	-	-	-	-	-	-	-	-	R	R	C	-	-	-	-	-
Y																
Yeast	R	R	-	-	-	-	-	-	R	R	R	-	-	R	R	R
Z																
Zinc Chloride	R	R	R	R	-	-	-	-	R	R	R	-	-	-	-	-
Zinc Nitrate	R	R	R	R	-	-	-	-	R	R	R	-	-	-	-	-
Zinc Salts	R	R	C	-	-	-	-	-	R	R	R	-	-	R	R	R
Zinc Sulfate	R	R	R	R	-	-	-	-	R	R	R	-	-	-	-	-

In the table the figure stands for the below mentioned:

R - Stands for recommended | **C** - Stands for use with caution | **N** - Stands for not recommended

CHEMICAL RESISTANCE CHART

Chemical & Concentration Formula	Concentration	ABS	PP	PVC	PE
H ₃ PO ₄	85%	-	100	60	23
	98%	-	-	-	-
Potassium 1	0%	-	82	23	60
Permanganate (KMnO ₄)	25%	-	23	23	60
Soap	-	23	60	60	R to 60
Sodium Bicarbonate (NaHCO ₃)	23%	23	100	60	60
Sodium Carbonate (NaCl)	23	100	60	60	-
Sodium Hypo Chlorite (NaOClO 5H ₂ O)	-	49	23	23	60
Sulfur S	-	-	100	60	60
	30%	49	82	60	60
	50%	23	82	60	49
	60%	C to 23	23	60	49
	70%	C to 23	23	60	R to 49
Sulfuric Acid (H ₂ SO ₄)	80%	C to 23	82	60	R to 49
	90%	C to 23	66	23	49
	93%	N	C to 23	23	C to 23
	94% - 98%	N	C to 23	N	C to 23
	100%	N	C to 23	N	C to 23
Urea	-	-	82	60	60
Urine	-	71	82	60	60
Water, Acid Mild	-	71	60	60	60
H ₂ O	-	71	60	60	60
Water (H ₂ O), Deionized	-	71	60	60	60
Water (H ₂ O), Distilled	-	71	100	100	60
Water (H ₂ O), Salt	-	71	100	60	60
Water (H ₂ O), Sea	-	71	100	60	60
Water (H ₂ O), Soft	-	71	100	60	60
Zinc Sulfate	-	71	82	60	60

PP-R IS AN IDEAL MATERIAL FOR HOT & COLD WATER PLUMBING SYSTEMS

RESISTANCE CODES

Code	Meaning	Typical Results
60	Plastic type is generally resistant to temperature (°C) indicated by code.	Swelling < 3% or weight loss < 0.5% and elongation at break not significantly changed.
R to 23	Plastic type is generally resistant to temperature (°C) indicated by code and may have limited resistance at higher temperatures.	Swelling < 3% or weight loss < 0.5% and elongation at break not significantly have limited resistance at higher temperatures changed.
C to 23	Plastic type is generally resistant to temperature (°C) indicated by code and may be suitable for some conditions	Swelling 3-8% or weight loss < 0.5-5% and / or elongation at break decreased by suitable for some conditions. < 50%.
N	Plastic type is not resistant.	Swelling < 8% or weight loss < 5% and / or elongation at break decreased by > 50%.
-	Data not available	Data not available

- Chemicals that do not normally affect the properties of an unstressed thermoplastic may cause completely different behavior (such as stress cracking) when under thermal or mechanical stress (such as constant internal pressure or frequent thermal or mechanical stress cycles).
- Unstressed immersion test chemical resistance information is applicable only when the thermoplastic pipe will not be subject to mechanical or thermal stress that is constant or cycles frequently.
- When the pipe will be subject to a continuous applied mechanical or thermal stress or to combinations of chemicals, testing that duplicates the expected field conditions as closely as possible should be performed on representative samples of the pipe product to properly evaluate plastic pipe for use in this application

INSTALLATION IMAGES

GREENFIT PP-R INSTALLATION



BLUE GREENFIT PP-R INSTALLATION



PP-R IS AN IDEAL MATERIAL FOR HOT & COLD WATER PLUMBING SYSTEMS

AUTHORISED DISTRIBUTOR :



Whatsapp No. +91-91670 39334

www.princeenterprise.co.in

PRINCE ENTERPRISE

Add: Kasturi Complex, Gala No.K-1, Anjur Road Rahnal Village, Bhiwandi, Dist - Thane - 421302,

Office No. +91-7410078051 / 52 / 53.

Email: princeenterprise1@gmail.com